

Service Instructions

80%, 90%, 95% Gas Furnaces & Accessories

ACS, ACV, ADS, ADV, AMH, AMS, AMV, DCS, DDS,
DHS, DMS, GCH, GCS, GDH, GDS, GCV, GHS, GKS,
GME, GMH, GMS, GMV

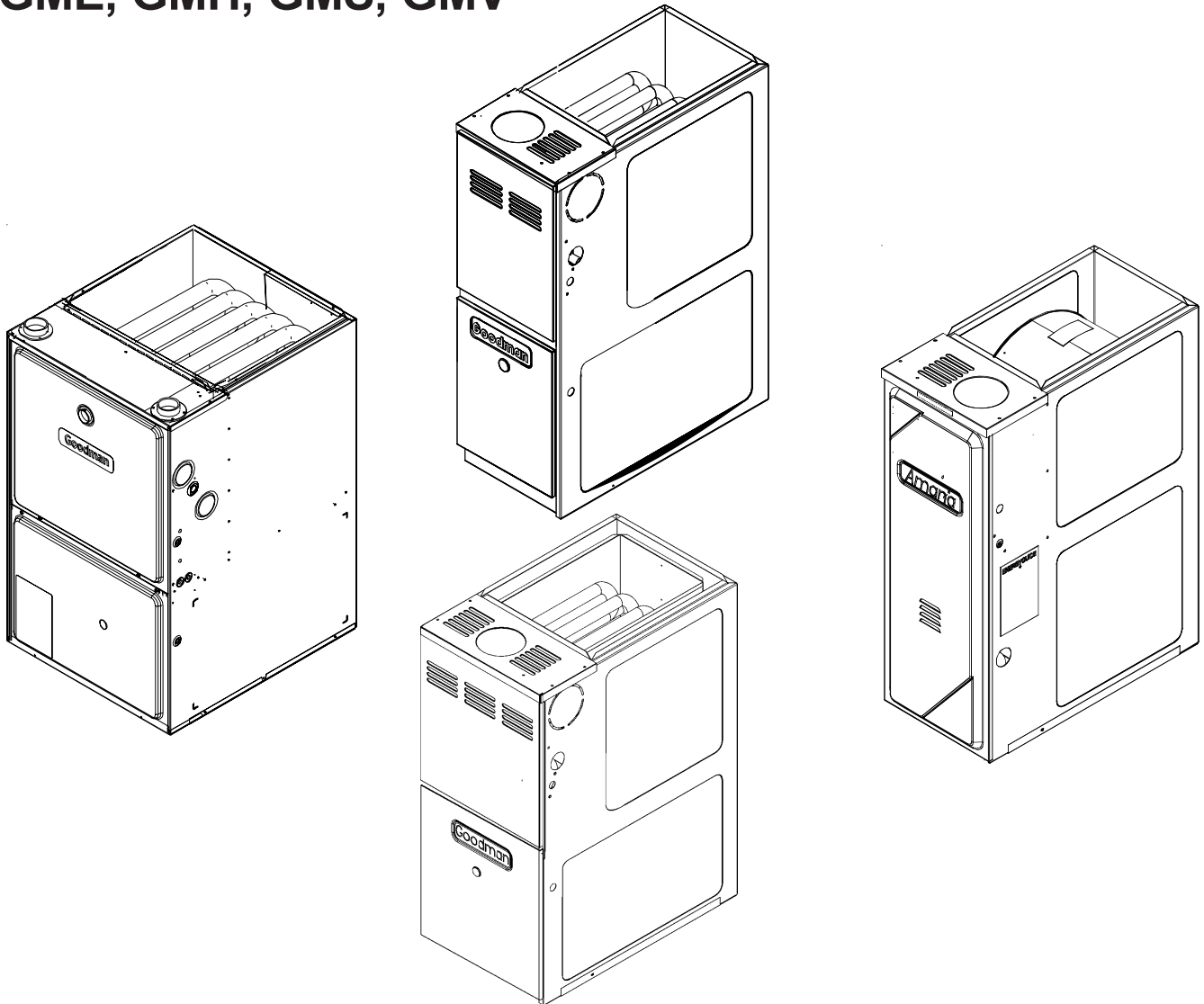

This manual is to be used by qualified, professionally trained HVAC technicians only. Goodman does not assume any responsibility for property damage or personal injury due to improper service procedures or services performed by an unqualified person.

RS6610004 Rev. 2
November 2007

TABLE OF CONTENTS

IMPORTANT INFORMATION	2-3	POLARIZATION & PHASING	92
PRODUCT IDENTIFICATION	4-14	MAINTENANCE	93-95
OPERATING INSTRUCTIONS	20-22	SERVICING	96-128
ACCESSORIES	23-27	TROUBLESHOOTING	105-106
PRODUCT DESIGN	28-79	SERVICING TABLE OF CONTENTS	98
SYSTEM OPERATION	80-91	ACCESSORIES WIRING DIAGRAMS	129-131

IMPORTANT INFORMATION

Pride and workmanship go into every product to provide our customers with quality products. It is possible, however, that during its lifetime a product may require service. Products should be serviced only by a qualified service technician who is familiar with the safety procedures required in the repair and who is equipped with the proper tools, parts, testing instruments and the appropriate service manual. **REVIEW ALL SERVICE INFORMATION IN THE APPROPRIATE SERVICE MANUAL BEFORE BEGINNING REPAIRS.**

IMPORTANT NOTICES FOR CONSUMERS AND SERVICERS

RECOGNIZE SAFETY SYMBOLS, WORDS AND LABELS

WARNING

THIS UNIT SHOULD NOT BE CONNECTED TO, OR USED IN CONJUNCTION WITH, ANY DEVICES THAT ARE NOT DESIGN CERTIFIED FOR USE WITH THIS UNIT OR HAVE NOT BEEN TESTED AND APPROVED BY GOODMAN. SERIOUS PROPERTY DAMAGE OR PERSONAL INJURY, REDUCED UNIT PERFORMANCE AND/OR HAZARDOUS CONDITIONS MAY RESULT FROM THE USE OF DEVICES THAT HAVE NOT BEEN APPROVED OR CERTIFIED BY GOODMAN.

WARNING

INSTALLATION AND REPAIR OF THIS UNIT SHOULD BE PERFORMED **ONLY** BY INDIVIDUALS MEETING THE REQUIREMENTS OF AN ENTRY LEVEL TECHNICIAN AS SPECIFIED BY THE AIR CONDITIONING AND REFRIGERATION INSTITUTE (ARI). ATTEMPTING TO INSTALL OR REPAIR THIS UNIT WITHOUT SUCH BACKGROUND MAY RESULT IN PRODUCT DAMAGE, PERSONAL INJURY, OR DEATH.

WARNING

TO PREVENT THE RISK OF PROPERTY DAMAGE, PERSONAL INJURY, OR DEATH, DO NOT STORE COMBUSTIBLE MATERIALS OR USE GASOLINE OR OTHER FLAMMABLE LIQUIDS OR VAPORS IN THE VICINITY OF THIS APPLIANCE.

WARNING

GOODMAN WILL NOT BE RESPONSIBLE FOR ANY INJURY OR PROPERTY DAMAGE ARISING FROM IMPROPER SERVICE OR SERVICE PROCEDURES. IF YOU INSTALL OR PERFORM SERVICE ON THIS UNIT, YOU ASSUME RESPONSIBILITY FOR ANY PERSONAL INJURY OR PROPERTY DAMAGE WHICH MAY RESULT. MANY JURISDICTIONS REQUIRE A LICENSE TO INSTALL OR SERVICE HEATING AND AIR CONDITIONING EQUIPMENT.

WARNING

HIGH VOLTAGE
DISCONNECT **ALL** POWER BEFORE SERVICING OR INSTALLING THIS UNIT. MULTIPLE POWER SOURCES MAY BE PRESENT. FAILURE TO DO SO MAY CAUSE PROPERTY DAMAGE, PERSONAL INJURY OR DEATH.



IMPORTANT INFORMATION



WARNING

IF THE INFORMATION IN THESE INSTRUCTIONS IS NOT FOLLOWED EXACTLY, A FIRE OR EXPLOSION MAY RESULT CAUSING PROPERTY DAMAGE, PERSONAL INJURY OR LOSS OF LIFE.

- DO NOT STORE OR USE GASOLINE OR OTHER FLAMMABLE VAPORS AND LIQUIDS IN THE VICINITY OF THIS OR ANY OTHER APPLIANCE.
- **WHAT TO DO IF YOU SMELL GAS:**
 - DO NOT TRY TO LIGHT ANY APPLIANCE.
 - DO NOT TOUCH ANY ELECTRICAL SWITCH; DO NOT USE ANY PHONE IN YOUR BUILDING.
 - IMMEDIATELY CALL YOUR GAS SUPPLIER FROM A NEIGHBOR'S PHONE. FOLLOW THE GAS SUPPLIER'S INSTRUCTIONS.
 - IF YOU CANNOT REACH YOUR GAS SUPPLIER, CALL THE FIRE DEPARTMENT.
- INSTALLATION AND SERVICE MUST BE PERFORMED BY A QUALIFIED INSTALLER, SERVICE AGENCY OR THE GAS SUPPLIER.



WARNING

SHOULD OVERHEATING OCCUR OR THE GAS SUPPLY FAIL TO SHUT OFF, TURN OFF THE MANUAL GAS SHUTOFF VALVE EXTERNAL TO THE FURNACE BEFORE TURNING OFF THE ELECTRICAL SUPPLY.



DANGER PELIGRO



CARBON MONOXIDE POISONING HAZARD

Special Warning for Installation of Furnace or Air Handling Units in Enclosed Areas such as Garages, Utility Rooms or Parking Areas

Carbon monoxide producing devices (such as an automobile, space heater, gas water heater, etc.) should not be operated in enclosed areas such as unventilated garages, utility rooms or parking areas because of the danger of carbon monoxide (CO) poisoning resulting from the exhaust emissions. If a furnace or air handler is installed in an enclosed area such as a garage, utility room or parking area and a carbon monoxide producing device is operated therein, there must be adequate, direct outside ventilation.

This ventilation is necessary to avoid the danger of CO poisoning which can occur if a carbon monoxide producing device continues to operate in the enclosed area. Carbon monoxide emissions can be (re)circulated throughout the structure if the furnace or air handler is operating in any mode.

CO can cause serious illness including permanent brain damage or death.

B10259-216

To locate an authorized servicer, please consult your telephone book or the dealer from whom you purchased this product. For further assistance, please contact:

CONSUMER INFORMATION LINE GOODMAN® BRAND PRODUCTS

TOLL FREE

1-877-254-4729 (U.S. only)

email us at:

customerservice@goodmanmfg.com

fax us at: (731) 863-2382

(Not a technical assistance line for dealers.)

Outside the U.S., call 1-713-861-2500.

(Not a technical assistance line for dealers.)

Your telephone company will bill you for the call.

CONSUMER INFORMATION LINE AMANA® BRAND PRODUCTS

TOLL FREE

1-877-254-4729 (U.S. only)

email us at:

hac.consumer.affairs@amanahvac.com

fax us at: (931) 438-4362

(Not a technical assistance line for dealers.)

Outside the U.S., call 1-931-433-6101.

(Not a technical assistance line for dealers.)

Your telephone company will bill you for the call.

PRODUCT IDENTIFICATION

The model and manufacturing number are used for positive identification of component parts used in manufacturing. Please use these numbers when requesting service or parts information.

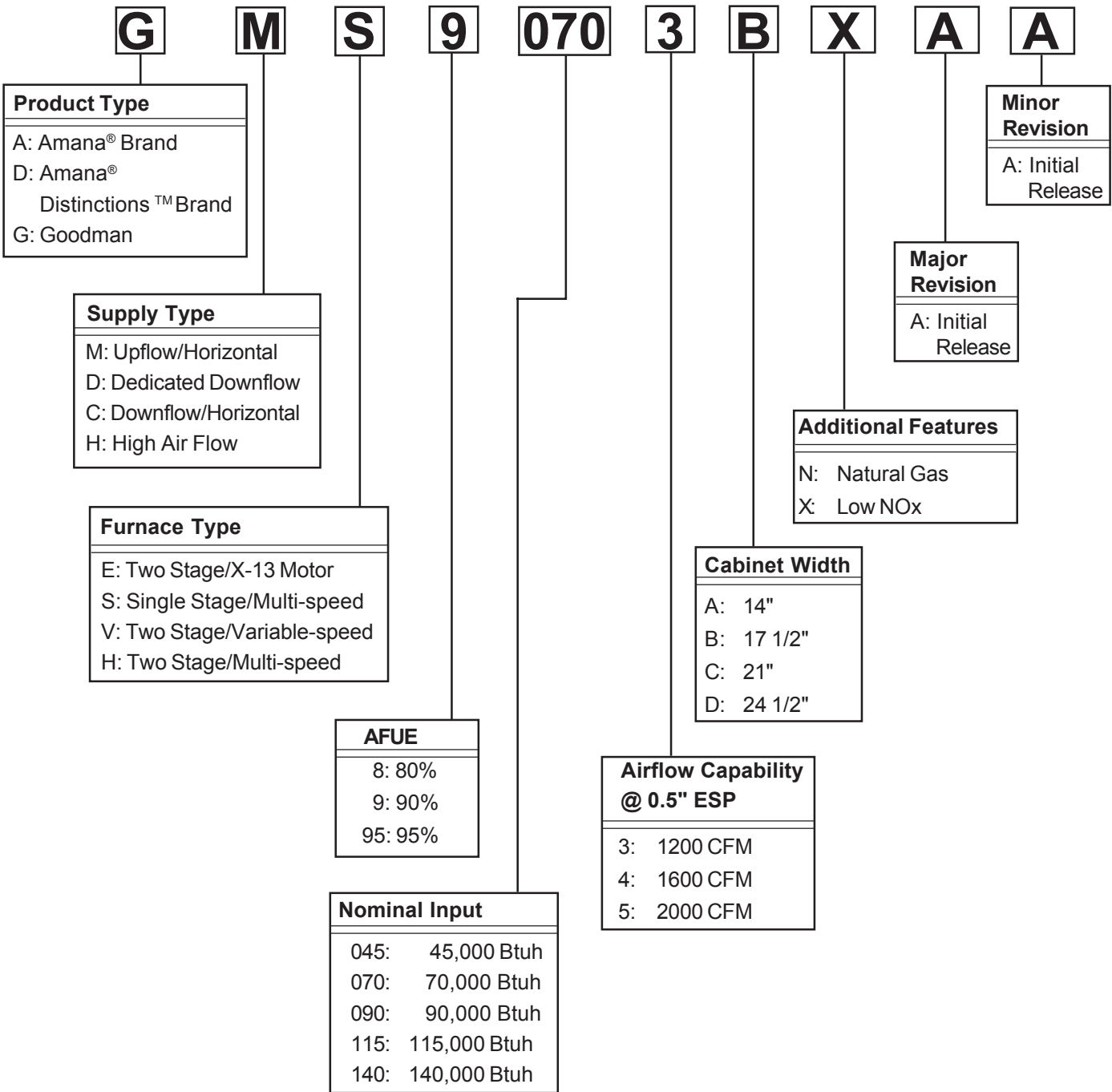

PRODUCT IDENTIFICATION

MODEL #	MFG. #	80 % GAS FURNACES
ADS8*	ADS8****AA	Amana® Brand 80% Gas Furnace , 39" tall, Dedicated Downflow , Induced Draft, 39" 80% furnace redesign changes that include new two tone grey painted cabinet and front panels, PSC motor, standardized blower decks, and a Surestart Silicon Nitride Igniter. Left or right gas pipe entry. The furnaces also feature an integrated electronic ignition control and a Million-Air stainless steel tubular heat exchanger. Chassis sizes are now 14", 17.5", 21" wide.
ADV8*	ADV8****AA	Amana® Brand 80% Variable Speed Gas Furnace - 2 stage heat gas furnace, 39" tall, Dedicated Downflow, 2-Stage Induced Draft, new two tone grey painted cabinet and front panels, standardized blower decks and a Surestart Silicon Nitride Igniter. Left or right gas pipe entry. The furnaces also feature an integrated electronic ignition control and Million-Air stainless steel tubular heat exchanger. Chassis sizes are now 17.5", 21" wide.
	ADV8****BA ADV8****BA ADV8****BB	Amana® Brand 80% Variable Speed Gas Furnace - 2 stage heat gas furnace, 39" tall, Dedicated Downflow, 2-Stage Induced Draft, new two tone grey painted cabinet and front panels, standardized blower decks and a Surestart Silicon Nitride Igniter. Left or right gas pipe entry. The furnaces also feature an integrated electronic ignition control, 120 volt silicon nitride igniter and Million-Air stainless steel tubular heat exchanger. Chassis sizes are now 17.5", 21" wide. BB models utilized the round nose inducer motor.
AMH8*	AMH8****AA AMH8****AB AMH8****AC	Amana® Brand 80% Gas Furnace , 39" tall, Upflow/Horizontal Left or Right, Induced Draft, new grey painted cabinet and front panels, PSC motor, standardized blower decks and a 120V silicon nitride igniter. Left or right gas pipe entry. The furnaces also feature an integrated electronic ignition control and aluminized steel tubular heat exchanger. Chassis sizes are now 14", 17.5" 21, and 24.5" wide. ***AB Models used a round nose inducer motor. ***AC models revert back to Jakel square nose inducer.
AMS8*	AMS8****AA	Amana® Brand Gas Furnace , 39" tall, Upflow/Horizontal Right or Left, Induced Draft, furnace redesign changes that include new two tone grey painted cabinet and front panels, PSC motor, standardized blower decks and a Surestart Silicon Nitride Igniter. Left or right gas pipe entry. The furnaces also feature an integrated electronic ignition control and a Million-Air stainless steel tubular heat exchanger. Chassis sizes are now 14", 17.5", 21" and 24.5" wide.
AMV8*	AMV8****AA	Amana® Brand 80% Variable Speed Gas Furnace - 2 stage heat gas furnace, 39" tall, Upflow/Horizontal Left or Right, 2-Stage Induced Draft, new two tone grey painted cabinet and front panels, standardized blower decks and a Surestart Silicon Nitride Igniter. Left or right gas pipe entry. The furnaces also feature an integrated electronic ignition control and Million-Air stainless steel tubular heat exchanger. Chassis sizes are now 17.5", 21" wide.
	AMV8****BA AMV8****BA AMV8****BB	Amana® Brand 80% Variable Speed Gas Furnace - 2 stage heat gas furnace, 39" tall, Dedicated Downflow, 2-Stage Induced Draft, new two tone grey painted cabinet and front panels, standardized blower decks and a Surestart Silicon Nitride Igniter. Left or right gas pipe entry. The furnaces also feature an integrated electronic ignition control, 120 volt silicon nitride igniter and Million-Air stainless steel tubular heat exchanger. Chassis sizes are now 17.5", 21" wide. BB models used the round nose inducer motor.
DDS8*	DDS8****AA	Amana® Distinctions™ Brand 80% Gas Furnace , 39" tall, Dedicated Downflow , Induced Draft, furnace redesign changes that include new two tone grey painted cabinet and front panels, PSC motor, standardized blower decks and a Carbide Mini-Igniter. Left or right gas pipe entry. The furnaces also feature an integrated electronic ignition control and aluminized steel tubular heat exchanger. Chassis sizes are now 14", 17.5" and 21" wide.
DHS8*	DHS8****AA	Amana® Distinctions™ Brand 80% Gas Furnace , 39" tall, Upflow/Horizontal Left or Right, (High Air Flow design), Induced Draft, furnace design changes that include new two tone grey painted cabinet and front panels, PSC motor, standardized blower decks and a Carbide Mini-Igniter. Left or right gas pipe entry. The furnaces also feature an integrated electronic ignition control and aluminized steel tubular heat exchanger. Chassis sizes are now 14", 17.5", 21" wide.
DMS8*	DMS8****AA	Amana® Distinctions™ Brand 80% Gas Furnace , 39" tall, Upflow/Horizontal Left or Right, Induced Draft, furnace design changes that include new two tone grey painted cabinet and front panels, PSC motor, standardized blower decks and a Carbide Mini-Igniter. Left or right gas pipe entry. The furnaces also feature an integrated electronic ignition control and aluminized steel tubular heat exchanger. Chassis sizes are now 14", 17.5", 21" and 24.5" wide.
GDH8*	GDH8****AA GDH8****AB GDH8****AC	Goodman® Brand 80% Gas Furnace , 39" tall, Dedicated Downflow , Induced Draft, new grey painted cabinet and front panels, PSC motor, standardized blower decks and a 120V Silicon Nitride igniter. Left or right gas pipe entry. The furnaces also feature an integrated electronic ignition control and aluminized steel tubular heat exchanger. Chassis sizes are now 14", 17.5" and 21" wide. ***AB Models used a round nose inducer motor. ***AC models revert back to Jakel square nose inducer.
GDS8*	GDS8****AA GDS8****BA GDS8****BB GDS8****BC	Goodman® Brand 80% Gas Furnace , 39" tall, Dedicated Downflow , 2-stage/multi-speed, Induced Draft, new grey painted cabinet and front panels, PSC motor, standardized blower decks and a Carbide Mini-Igniter. Left or right gas pipe entry. The furnaces also feature an integrated electronic ignition control and aluminized steel tubular heat exchanger. Chassis sizes are now 14", 17.5", 21" wide. ***BB Models used a round nose inducer motor. ***BC models revert back to Jakel square nose inducer.

PRODUCT IDENTIFICATION

MODEL #	MFG. #	80 % GAS FURNACES
GHS8*	GHS8****AA GHS8****BA GHS8****BB GHS8****BC GHS8****BD	Goodman® Brand 80% Gas Furnace , 39" tall, Upflow/Horizontal Left or Right, (<u>High Air Flow Design</u>), Induced Draft, new grey painted cabinet and front panels, PSC motor, standardized blower decks and a Carbide Mini-Igniter. Left or right gas pipe entry. The furnaces also feature an integrated electronic ignition control and aluminized steel tubular heat exchanger. Chassis sizes are now 14", 17.5", 21" wide. ***BB Models used a round nose inducer motor. ***BC models revert back to Jakel square nose inducer.
GME8*	GME8****AA GME8****AB GME8****AC	Goodman® Brand 80% Gas Furnace , 39" tall, Upflow/Horizontal Left or Right, Induced Draft, new grey painted cabinet and front panels, X-13 motor, standardized blower decks and a 120V silicon nitride igniter.. Left or right gas pipe entry. The furnaces also feature an integrated electronic ignition control and aluminized steel tubular heat exchanger. Chassis sizes are now 17.5" and 21" wide. ***AB Models used a round nose inducer motor. ***AC models revert back to Jakel square nose inducer.
GMH8*	GMH8****AA GMH8****AB GMH8****AC	Goodman® Brand 80% Gas Furnace , 39" tall, Upflow/Horizontal Left or Right, Induced Draft, new grey painted cabinet and front panels, PSC motor, standardized blower decks and a 120V silicon nitride igniter. Left or right gas pipe entry. The furnaces also feature an integrated electronic ignition control and aluminized steel tubular heat exchanger. Chassis sizes are now 14", 17.5" and 21" wide. ***AB Models used a round nose inducer motor. ***AC models revert back to Jakel square nose inducer.
GMS8*	GMS8****AA GMS8****BA GMS8****BB GMS8****BC GMS8****BD	Goodman® Brand 80% Gas Furnace , 39" tall, Upflow/Horizontal Left or Right, Induced Draft, new grey painted cabinet and front panels, PSC motor, standardized blower decks and a Carbide Mini-Igniter. Left or right gas pipe entry. The furnaces also feature an integrated electronic ignition control and aluminized steel tubular heat exchanger. Chassis sizes are now 14", 17.5", 21" and 24.5" wide. ***BB Models used a round nose inducer motor. ***BC models revert back to Jakel square nose inducer.
GMV8*	GMV8****AA GMV8****BA	Goodman® Brand 80% Variable Speed - 2 stage heat Gas Furnace, 39" tall, Upflow/Horizontal Left or Right, 2-stage Induced Draft, new grey painted cabinet and front panels, standardized blower decks and a 120V Silicon Nitride Ignitor. Left or right gas pipe entry. The furnaces also feature an integrated electronic ignition control and aluminized steel tubular heat exchanger. Chassis sizes of 17.5", 21" wide.

PRODUCT IDENTIFICATION

MODEL #	MFG. #	DESCRIPTION
ACS9*	P1257001F through P1257006F	Amana® Brand 90% Gas Furnace , Downflow/Horizontal Left and Right, 40" tall, Induced Draft, new two tone grey painted cabinet and front panels, PSC motor, standardized blower decks and a Surestart Silicon Nitride Igniter. Left or right gas pipe entry. The furnaces also feature an integrated electronic ignition control and a Million-Air stainless steel tubular heat exchanger. NOx Certified. Chassis sizes are now 17.5", 21" and 24.5" wide.
ACS9*	P1257007F through P1257010F	Amana® Brand 90% Gas Furnace , Downflow/Horizontal Left and Right, 40" tall, Induced Draft, new two tone grey painted cabinet and front panels, PSC motor, standardized blower decks and a Surestart Silicon Nitride Igniter. Left or right gas pipe entry. The furnaces also feature an integrated electronic ignition control and a Million-Air stainless steel tubular heat exchanger. NOx Certified. Chassis sizes are now 17.5", 21" and 24.5" wide. (Note: The "P" numbers to the left include the following design changes.) Incorporates a new crimped designed blower housing and a new blower deck. The crimped blower housing will not fit inside of the previous "P" numbers for this same model. Redesigned 90° drain elbow by adding a side drain port hole. The side port drain tube is only used when placing the furnace in the horizontal left application.
ACV9*	P1257703F, P1257705F	Amana® Brand 90% Variable Speed - 2 stage Gas Furnace, Downflow/Horizontal Left and Right, 40" tall, 2-stage Induced Draft, new two tone grey painted cabinet and front panels, standardized blower decks and a Surestart Silicon Nitride Igniter. Left or right gas pipe entry. The furnaces also feature an integrated electronic ignition control and a Million-Air stainless steel tubular heat exchanger. NOx Certified. Chassis sizes are now 21" and 24.5" wide.
ACV9*	P1257707F	Amana® Brand 90% Variable Speed - 2 stage Gas Furnace, Downflow/Horizontal Left and Right, 40" tall, 2-stage Induced Draft, new two tone grey painted cabinet and front panels, standardized blower decks and a Surestart Silicon Nitride Igniter. Left or right gas pipe entry. The furnaces also feature an integrated electronic ignition control and a Million-Air stainless steel tubular heat exchanger. NOx Certified. Chassis sizes are now 21" and 24.5" wide. (Note: The "P" numbers to the left include the following design changes.) Incorporates a new crimped designed blower housing and a new blower deck. The crimped blower housing will not fit inside of the previous "P" numbers for this same model. We also have a new drain elbow with a side drain port hole added. It is used when placing the furnace in the horizontal left application.
AMS9*	P1256601F P1256606F	Amana® Brand 90% Gas Furnace , Upflow/Horizontal Left and Right, 40" tall, Induced Draft, new two tone grey painted cabinet and front panels, standardized blower decks and a Surestart Silicon Nitride Igniter. Left or right gas pipe entry. The furnaces also feature an integrated electronic ignition control and a Million-Air stainless steel tubular heat exchanger. NOx Certified. Chassis sizes are now 17.5", 21" and 24.5" wide.
AMS9*	P1256607F through P1256610F	Amana® Brand 90% Gas Furnace , Upflow/Horizontal Left and Right, 40" tall, Induced Draft, new two tone grey painted cabinet and front panels, standardized blower decks and a Surestart Silicon Nitride Igniter. Left or right gas pipe entry. The furnaces also feature an integrated electronic ignition control and a Million-Air stainless steel tubular heat exchanger. NOx Certified. Chassis sizes are now 17.5", 21" and 24.5" wide. (Note: The "P" numbers to the left include the following design changes.) Incorporates a new crimped designed blower housing and a new blower deck. The crimped blower housing will <u>not</u> fit inside of the previous "P" numbers for this same model. Redesigned 90° drain elbow by adding a side drain port hole. The side port drain tube is only used when placing the furnace in the horizontal left application.

PRODUCT IDENTIFICATION

MODEL #	MFG. #	DESCRIPTION
AMH95	AMH95***AA AMH95***AB AMH95***AC	Amana® Brand 95% Gas Furnace , Upflow/Horizontal Left or Right, 40" tall, Induced Draft, new two tone grey painted cabinet and front panels, standardized blower decks and a 120V Silicon Nitride Igniter. Left or right gas pipe entry. The furnaces also feature an integrated electronic ignition control and a Million-Air stainless steel tubular heat exchanger. NOx Certified. Chassis sizes are now 17.5", 21" and 24.5" wide. Two stage heat, single stage cooling.
AMS95	AMS95***AA AMS95***AB	Amana® Brand 95% Gas Furnace , Upflow/Horizontal Left and Right, 40" tall, Induced Draft, new two tone grey painted cabinet and front panels, standardized blower decks and a Surestart Silicon Nitride Igniter. Left or right gas pipe entry. The furnaces also feature an integrated electronic ignition control and a Million-Air stainless steel tubular heat exchanger. NOx Certified. Chassis sizes are now 17.5", 21" and 24.5" wide.
AMV9*	P1257401F, P1257403F, P1257405F through P1257406F	Amana® Brand 90% Variable Speed - 2 stage Gas Furnace, Upflow/Horizontal Left and Right, 40" tall, 2-stage Induced Draft, furnace redesign changes that include new two tone grey painted cabinet and front panels, standardized blower decks and a Surestart Silicon Nitride Igniter. Left or right gas pipe entry. The furnaces also feature an integrated electronic ignition control and a Million-Air stainless steel tubular heat exchanger. NOx Certified. Chassis sizes are now 17.5", 21" and 24.5" wide.
AMV9*	P1257407F, P1257408F	Amana® Brand 90% Variable Speed - 2 stage Gas Furnace, Upflow/Horizontal Left and Right, 40" tall, 2-stage Induced Draft, furnace redesign changes that include new two tone grey painted cabinet and front panels, standardized blower decks and a Surestart Silicon Nitride Igniter. Left or right gas pipe entry. The furnaces also feature an integrated electronic ignition control and a Million-Air stainless steel tubular heat exchanger. NOx Certified. Chassis sizes are now 17.5", 21" and 24.5" wide. (Note: The "P" numbers to the left include the following design changes.) Incorporates a new crimped designed blower housing and a new blower deck. The crimped blower housing will not fit inside of the previous "P" numbers for this same model. Redesigned 90° drain elbow by adding a side drain port hole. The side port drain tube is only used when placing the furnace in the horizontal left application.

PRODUCT IDENTIFICATION

MODEL #	MFG. #	DESCRIPTION
DCS9*	P1257102F, P1257104F, P1257106F	Amana® Distinctions™ Brand 90% Gas Furnace , Downflow/Horizontal Left and Right, 40" tall, Induced Draft, furnace design changes that include new two tone grey painted cabinet and front panels, PSC motor, standardized blower decks and a Carbide Mini-Igniter. Left or right gas pipe entry. The furnaces also feature an integrated electronic ignition control and aluminized steel tubular heat exchanger. NOx Certified. Chassis sizes are now 17.5", 21" and 24.5" wide.
DCS9*	P1257107F P1257108F	Amana® Distinctions™ Brand 90% Gas Furnace , Downflow/Horizontal Left and Right, 40" tall, Induced Draft, furnace design changes that include new two tone grey painted cabinet and front panels, PSC motor, standardized blower decks and a Carbide Mini-Igniter. Left or right gas pipe entry. The furnaces also feature an integrated electronic ignition control and aluminized steel tubular heat exchanger. NOx Certified. Chassis sizes are now 17.5", 21" and 24.5" wide. (Note: The "P" numbers to the left include the following design changes.) Incorporates a new crimped designed blower housing and a new blower deck. The crimped blower housing will not fit inside of the previous "P" numbers for this same model. Redesigned 90° drain elbow by adding a side drain port hole. The side port drain tube is only used when placing the furnace in the horizontal left application.
DMS9*	P1256701F, P1256706F	Amana® Distinctions™ Brand 90% Gas Furnace , Upflow/Horizontal Left or Right, 40" tall, Induced Draft, furnace design changes that include new two tone grey painted cabinet and front panels, PSC motor, standardized blower decks and a Carbide Mini-Igniter. Left or right gas pipe entry. The furnaces also feature an integrated electronic ignition control and aluminized steel tubular heat exchanger. NOx Certified. Chassis sizes are now 17.5", 21" and 24.5" wide.
DMS9*	P1256707F through P1256710F	Amana® Distinctions™ Brand 90% Gas Furnace , Upflow/Horizontal Left or Right, 40" tall, Induced Draft, furnace design changes that include new two tone grey painted cabinet and front panels, PSC motor, standardized blower decks and a Carbide Mini-Igniter. Left or right gas pipe entry. The furnaces also feature an integrated electronic ignition control and aluminized steel tubular heat exchanger. NOx Certified. Chassis sizes are now 17.5", 21" and 24.5" wide. (Note: The "P" numbers to the left include the following design changes.) Incorporates a new crimped designed blower housing and a new blower deck. The crimped blower housing will not fit inside of the previous "P" numbers for this same model. Redesigned 90° drain elbow by adding a side drain port hole. The side port drain tube is only used when placing the furnace in the horizontal left application.

PRODUCT IDENTIFICATION

MODEL #	MFG. #	DESCRIPTION
GCS9*	P1257201F, P1257202F P1257204F, P1257206F	Goodman® Brand 90% Gas Furnace. Downflow/Horizontal Left and Right, 40" tall, Induced Draft, new grey painted cabinet and front panels, PSC motor, standardized blower decks and a Carbide Mini-Igniter. Left or right gas pipe entry. The furnaces also feature an integrated electronic ignition control and aluminized steel tubular heat exchanger. NOx Certified. Chassis sizes are now 17.5", 21" and 24.5" wide.
GCS9*	P1257207F through P1257209F	Goodman® Brand 90% Gas Furnace. Downflow/Horizontal Left and Right, 40" tall, Induced Draft, new grey painted cabinet and front panels, PSC motor, standardized blower decks and a Carbide Mini-Igniter. Left or right gas pipe entry. The furnaces also feature an integrated electronic ignition control and aluminized steel tubular heat exchanger. NOx Certified. Chassis sizes are now 17.5", 21" and 24.5" wide. (Note: The "P" numbers to the left include the following design changes.) Incorporates a new crimped designed blower housing and a new blower deck. The crimped blower housing will not fit inside of the previous "P" numbers for this same model. Redesigned 90° drain elbow by adding a side drain port hole. The side port drain tube is only used when placing the furnace in the horizontal left application.
GCH9*	GCH9****AA GCH9****AB	Goodman® Brand 90% Gas Furnace. Downflow/Horizontal Left and Right, 40" tall, Induced Draft, new grey painted cabinet and front panels, PSC motor, standardized blower decks and a 120V Silicon Nitride igniter. Left or right gas pipe entry. The furnaces also feature an integrated electronic ignition control and aluminized steel tubular heat exchanger. NOx Certified. Chassis size are now 17.5", 21" and 24.5" wide. Two stage heat, single stage cooling.
GCV9*	P1257803F, P1257805F	Goodman® Brand 90% Variable Speed - 2 Stage Gas Furnace, 40" tall, Upflow/Horizontal Left or Right, Induced Draft, new grey painted cabinet and front panels, standardized blower decks and a Carbide Mini-Igniter. Left or right gas pipe entry. The furnaces also feature an integrated electronic ignition control and aluminized steel tubular heat exchanger. NOx Certified. Chassis sizes are now 21" and 24.5" wide. (BA models use Surestat Silicon Nitride igniters.)
GKS9*	GKS9****AA GKS9****AB GKS9****AC	Goodman® Brand 92.1% Gas Furnace. Upflow/Horizontal Left or Right, 40" tall, Induced Draft, new grey painted cabinet and front panels, PSC motor, standardized blower decks and a Carbide Mini-Igniter. Left or right gas pipe entry. The furnaces also feature an integrated electronic ignition control and aluminized steel tubular heat exchanger. NOx Certified. Chassis sizes are now 17.5", 21" and 24.5" wide.
GMS9*	P1256801F through P1256802F P1256804F, P1256806F	Goodman® Brand 90% Gas Furnace. Upflow/Horizontal Left or Right, 40" tall, Induced Draft, new grey painted cabinet and front panels, PSC motor, standardized blower decks and a Carbide Mini-Igniter. Left or right gas pipe entry. The furnaces also feature an integrated electronic ignition control and aluminized steel tubular heat exchanger. NOx Certified. Chassis sizes are now 17.5", 21" and 24.5" wide.
GMS9*	P1256807F through P1256809F	Goodman® Brand 90% Gas Furnace. Upflow/Horizontal Left or Right, 40" tall, Induced Draft, new grey painted cabinet and front panels, PSC motor, standardized blower decks and a Carbide Mini-Igniter. Left or right gas pipe entry. The furnaces also feature an integrated electronic ignition control and aluminized steel tubular heat exchanger. NOx Certified. Chassis sizes are now 17.5", 21" and 24.5" wide. (Note: The "P" numbers to the left include the following design changes.) Incorporates a new crimped designed blower housing and a new blower deck. The crimped blower housing will not fit inside of the previous "P" numbers for this same model. Redesigned 90° drain elbow by adding a side drain port hole. The side port drain tube is only used when placing the furnace in the horizontal left application.
GMS95*	GMS9****AA GMS9****AB	Goodman® Brand 95% Gas Furnace. Upflow/Horizontal Left or Right, 40" tall, Induced Draft, new grey painted cabinet and front panels, PSC motor, standardized blower decks and a Carbide Mini-Igniter. Left or right gas pipe entry. The furnaces also feature an integrated electronic ignition control and aluminized steel tubular heat exchanger. NOx Certified. Chassis sizes are now 17.5", 21" and 24.5" wide.
GMV9*	P1257603F - P1257607F	Goodman® Brand 90% Variable Speed - 2 stage heat Gas Furnace, Upflow/Horizontal Left or Right, 40" tall, 2-stage Induced Draft, new grey painted cabinet and front panels, standardized blower decks and a Carbide Mini-Igniter. Left or right gas pipe entry. The furnaces also feature an integrated electronic ignition control and aluminized steel tubular heat exchanger. NOx Certified. Chassis sizes of 17.5", 21" and 24.5" wide.

PRODUCT IDENTIFICATION

MODEL #	MFG. #	DESCRIPTION
GMV9*	P1257610F - P1257611F	<p>Goodman® Brand 90% Variable Speed - 2 stage heat Gas Furnace, Upflow/Horizontal Left or Right, 40" tall, 2-stage Induced Draft, new grey painted cabinet and front panels, standardized blower decks and a Carbide Mini-Igniter. Left or right gas pipe entry. The furnaces also feature an integrated electronic ignition control and aluminized steel tubular heat exchanger. NOx Certified. Chassis sizes of 17.5", 21" and 24.5" wide.</p> <p>(Note: The "P" numbers to the left include the following design changes.) Incorporates a new crimped designed blower housing and a new blower deck. The crimped blower housing will not fit inside of the previous "P" numbers for this same model. Redesigned 90° drain elbow by adding a side drain port hole. The side port drain tube is only used when placing the furnace in the horizontal left application.</p>
GMH95*	GMH95***AA GMH95***AB GMH95***AC	<p>Goodman® Brand 95% Gas Furnace, Upflow/Horizontal Left or Right, 40" tall, Induced Draft, new two tone grey painted cabinet and front panels, standardized blower decks and a 120V Silicon Nitride Igniter. Left or right gas pipe entry. The furnaces also feature an integrated electronic ignition control and a Million-Air stainless steel tubular heat exchanger. NOx Certified. Chassis sizes are now 17.5", 21" and 24.5" wide. Two stage heat, single stage cooling.</p>
GMV95*	GMV95***AA GMV95***AB GMV95***BA GMV95***BB	<p>Goodman® Brand 95% Variable Speed - 2 stage Gas Furnace, Upflow/Horizontal Left or Right, 40" tall, 2-stage Induced Draft, new grey painted cabinet and front panels, new standardized blower decks, new blower housing and a Carbide Mini-Igniter.(BA model has 120V Silicon Nitride igniters.) Left or right gas pipe entry. The furnaces also feature an integrated electronic ignition control and aluminized steel tubular heat exchanger. NOx Certified. Chassis sizes are now 17.5", 21" and 24.5" wide.</p>

PRODUCT IDENTIFICATION

MODEL #	MFG #	DESCRIPTION
AFE18-60A	N/A	Fossil Fuel Kit. The AFE18-60A control is designed for use where the indoor coil is located above/downstream of a gas or fossil fuel furnace when used with a heat pump. It will operate with single and two stage heat pumps and single and two stage furnaces. The AFE18-60A control will turn the heat pump unit off when the furnace is turned on. An anti-short cycle feature initiates a 3 minute timed off delay when the compressor goes off.
AMU1620 AMU1625 AMU2020 AMU2025 GMU1620 GMU1625 GMU2020 GMU2025	P1251305F P1251306F P1251307F P1251308F N/A	Media Air Cleaner. For use with current architectural grey Goodman® and Amana® Brand 80% and 90% variable speed furnace models. The Amana (AMU*) and Goodman (GMU*) Media Air Cleaner is a high efficiency air filtration device designed to remove dirt, dust, pollen and other microscopic particles from the air passing through it. Flexible performance range up to 2,000 CFM capacity. The air cleaner should be installed in the system so that all the system air is circulated through the air cleaner. The air cleaner will only remove the airborne contaminants delivered to it. Maximum performance is obtained when the system blower is set for continuous operation. Carbon filters (optional) are available.
ASAS-10 ASAS-11 ASAS-12 ASAS-18	P1251301F P1251302F P1251303F P1251304F	Electronic Air Cleaner. For use with current architectural grey Goodman® and Amana® Brand 80% and 90% variable speed furnace models. The High-Efficiency Electronic Air Cleaner is designed to remove air contaminants down to .01 microns. Carbon filters (optional) remove odors. Dual indicator lights show unit operation at a glance. Electronic proving switch cycles the air cleaner On/Off with the system fan. Durable powder-coat paint finish resists corrosion.
CFB17 CFB21 CFB24	P1228004F P1228005F P1228003F	Downflow Subbase Kit. For use with select Goodman®, Amana® Brand & Amana® Distinctions™ Brand furnace models ACS9, ACV9, DCS9, GCH9, GCS9, GCV9 . These kits are available for the following furnace widths: 17.5" wide (CFB17), 21" wide (CFB21) and 24" wide (CFB24). The kits must be used to prevent excessive temperature from reaching combustible materials, if the furnace is installed on a combustible floor. This subbase effectively separated the furnace base and plenum from combustible materials. To ensure safe installation, do not install the counterflow floor base directly on carpeting, tile, or other combustible material other than wood flooring.
DCVK-20 DCVK-30	P1254001F P1254002F	Concentric Vent Kit. For use with Amana® Brand furnace models ACS9, AMS9, AMS95, ACV9, AMV9, AMH95, DCS9, DMS9, GCS9, GMS9, GMS95, GCH9, GKS9, GCV9, GMV9, GMH95, GMV95 . This kit is designed to allow terminations of a direct vent furnace to be "concentrically" vented through a wall or roof. This kit allows a single penetration to support terminations for both the vent/flue and the combustion air intake pipe. The DCVK-20 (2") and DCVK-30 (3") kits are certified for models listed above. See specification sheets on future models for use of the vent kit.
0170K00000S	N/A	Side Wall Only Concentric Vent Kit. For use with 90% furnace models ACS9, AMS9, ACV9, AMV9, AMH95, DCS9, DMS9, GCH9, GCS9, GKS9, GMS9, GCV9, GMH95, GMV9, GMV95 . This kit is to be used with 2" or 3" vent systems. The vent kit must terminate outside the structure. This kit is NOT intended for use with single pipe (indirect vent) installations.

PRODUCT IDENTIFICATION

MODEL #	MFG #	DESCRIPTION
DEHUM1	P1227801F	Dehumidistat. For use with Goodman® and Amana® Brand two-stage variable speed furnace models ADV8, AMV8, ACV9, AMV9, GMV8, GCV9, GMV9, GMV95 . Wall mounted, 24 volt humidity control available as a Dehumidistat used to reduce the airflow in the air conditioning mode when necessary to lower the humidity in an occupied home to prevent dew build-up associated with high humidity levels. This control features a moisture-sensitive nylon element and also provides positive ON-OFF settings for manual operation. The control is a normally closed switch that opens on humidity rise causing the blower to switch to a lower speed to control the humidity within the structure.
EFR01	P1221001 P1221002F	External Filter Rack Kit. For use with Goodman® and Amana® Brand 90% upflow variable speed gas furnace models AMH95, AMS9, AMS95, GMH95, GMS9, GMS95, DMS9, AMV9, GMV9, GMV95 . This kit is intended to provide a location, external to the furnace casing, for installation of a permanent filter. The rack is mounted over the indoor air blower compartment area of either side panel, and provide filter retention as well as a location for attaching return air ductwork.
FTK03A	P1171304F P1171305F	Furnace Twinning Kit. This kit allows Goodman® or Amana® Brand single stage 80% and single stage 90% gas furnaces to operate at the same time from a single thermostat. The two furnaces to be "twinning" must be the exact same model with their circulating air blowers set to deliver the same air flow at the same time. The furnaces may deliver different CFM's in the cooling mode, if applicable. This kit cannot be used to control more than two furnaces.
HA02	P1129112F	High Altitude Kit. The kit is designed to convert Goodman®, Amana® Brand & Amana® Distinctions™ Brand 80% gas furnace models (AMH8*, AMS8*, ADS8*, DMS8*, DDS8*, DHS8*, GDS8*, GMH8*, GMS8*, GDS8*, GHS8*) for higher altitudes. This kit is required when installing these furnaces above their maximum rated altitude. This kit contains # 43-49, 55-58 gas orifices. The orifices in the kit have been selected as a result of testing with the American Gas Association. They will provide appropriate derating at the altitude listed in the High Altitude Charts as shown in the installation instructions of the kit.
HALP10	P1129112F	High Altitude Propane Gas Conversion Kit. Used on Goodman® and Amana® Brand 90% single stage (ACS9, AMS9, DCS9, DMS9, GCS9, GMS9) furnace models. This kit is required when installing furnaces above their maximum rated altitude. This kit contains propane gas orifices. The orifices in the kit have been selected as a result of testing with the American Gas Association. They will provide appropriate derating at the altitude listed in the High Altitude Charts as shown in the installation instructions of the kit.
HALP11	P1129113F	High Altitude Propane Gas Conversion Kit. Used on Goodman® and Amana® Brand 90% single stage (ACV9, AMV9, GCV9, GMV9, GMV95) furnace models. This kit is required when installing furnaces above their maximum rated altitude. This kit contains propane gas orifices. The orifices in the kit have been selected as a result of testing with the American Gas Association. They will provide appropriate derating at the altitude listed in the High Altitude Charts as shown in the installation instructions of the kit.
HALP13	P1129112F	High Altitude Propane Gas Conversion Kit. Used on Goodman® and Amana® Brand 90% two stage (ACV9, GCV9) furnace models. This kit is required when installing furnaces above their maximum rated altitude. This kit contains propane gas orifices. The orifices in the kit have been selected as a result of testing with the American Gas Association. They will provide appropriate derating at the altitude listed in the High Altitude Charts as shown in the installation instructions of the kit.

PRODUCT IDENTIFICATION

MODEL #	MFG #	DESCRIPTION
HANG11-12	P1210305F P1210306F	High Altitude Natural Gas Kit. For use with Goodman® and Amana® Brand 90% furnace models ACS9, AMS9, DCS9, DMS9, GCS9 and GMS9 . These kits are required when installing the furnaces above their maximum rated altitude. This kit contains natural gas orifices. The orifices in the kit have been selected with the American Gas Association. They will provide appropriate derating at the altitude listed in the High Altitude Charts as shown in the installations of the kit.
HANG13-14	P1210307F P1210308F	High Altitude Natural Gas Kit. For use with Goodman® and Amana® Brand 90% furnace models AMV9, GMV9, GMV95 . These kits are required when installing the furnaces above their maximum rated altitude. The orifices in the kit have been selected as a result of testing with the American Gas Association. They will provide appropriate derating at the altitude listed in the High Altitude Charts as shown in the installations of the kit.
HANG16	P1210310F	High Altitude Natural Gas Kit. For use with Goodman® and Amana® Brand 90% furnace models ACV9, GCV9 . These kits are required when installing the furnaces above their maximum rated altitude. The orifices in the kit have been selected as a result of testing with the American Gas Association. They will provide appropriate derating at the altitude listed in the High Altitude Charts as shown in the installations of the kit.
HAPS27-29	P1210518F through P1210520F	High Altitude Pressure Switch Kit. For use with selected Goodman® and Amana® Brand 90% furnace models AMS9, ACS9, DCS9, DMS9, GSC9, GMS9, AMV9, GMV9 and GMV95 . This kit contains a high altitude pressure switch that must be used at altitudes above the rated altitudes because of reduced air density.
HAPS31	P1210522F	High Altitude Pressure Switch Kit. For use with selected Goodman® and Amana® Brand 90% furnace models ACV9, GCV9 . This kit contains a high altitude pressure switch that must be used at altitudes above the rated altitudes because of reduced air density.
LPLP01	P1237701F	LP Gas Low Pressure Kit. Designed for application on Goodman® and Amana® Brand's 90% single-stage and two-stage gas fired furnace product installed on LP gas listed in this manual. The kit monitors gas line pressure with a pressure switch and disables the unit's gas valve if the line pressure drops below acceptable levels. Application of the LPLP kit is aimed at reducing the occurrence of sooted heat exchangers in product installed on LP gas.
LPT-00A	N/A	LP Conversion Kit. For use with Goodman®, Amana® Brand & Amana® Distinctions™ Brand models ADS8, AMS8, GDS8, GMS8, DMS8, DDS8, DHS8, GHS8, ACS9, AMS9, AMS95, DCS9, DMS9, GCS9, GKS9, GMS9 and GMS95 . This kit converts only single-stage gas fired units from natural to propane gas. The conversion from natural gas (as shipped from the factory) to propane gas requires: replacing the burner orifices, replacing gas valve regulator spring (all single stage units) and applying identification labels. NOx screens must be removed when converting 80% furnaces to this LP kit.
LPM-03B	N/A	LP Conversion Kit. For use with Goodman® and Amana® Brand 80% and 90% 2-stage variable speed models. This kit includes the LP gas valve, (1.25mm, # 55 orifices), installation instructions and a label to show that the furnace has been converted.
LPM-05	N/A	LP Conversion Kit. For use with Goodman® and Amana® Brand 2-stage variable speed models using a White-Rodgers 36G54 2-stage gas valve kit. Includes regulator springs, #55 orifices, instructions and a label to show the furnace has been converted to L.P.
RF000180	N/A	Internal Filter Retention Kit. For use with Goodman®, Amana® Brand & Amana® Distinctions™ Brand 90% upflow only furnaces. This kit allows a filter to be installed in the bottom of the furnace and contains enough hardware for (10) furnaces. This kit is NOT to be used on horizontal applications.
RF000181	N/A	Internal Filter Retention Kit. For use with Goodman®, Amana® Brand and Amana® Distinctions™ Brand 90% counterflow only furnaces. This kit allows a filter to be installed in the bottom of the furnace and contains enough hardware for (10) furnaces. This kit is NOT to be used on horizontal applications.
SBT14 SBT17 SBT21 SBT24	N/A	Downflow Subbase. For use with Goodman® and Amana® Brand 80% dedicated downflow furnace models ADV8, ADS8, GDS8 and GDH8 . These kits are available for the following furnace widths: 14" wide (SBT14) 17.5" wide (SBT17), 21" wide (SBT21) and 24" wide (SBT24).

ACCESSORIES

AMANA® BRAND & AMANA® DISTINCTIONS™ BRAND 80% FURNACE ACCESSORIES

Model Number	AFE180-60A	AMU	ASAS	DEHUM1	EFR01	FTK03A	HA02	LPM-03B	LPT-00A	SBT14	SBT17	SBT21	LPM-05
Description	Fossil Fuel Kit	Media Air Cleaners	Electronic Air Cleaner	Dehumidistat	External Filter Rack	Furnace Twinning Kit	High Altitude Natural Gas Kit	Propane Gas Conversion Kit	Propane Gas Conversion Kit	Downflow Subbase 14"	Downflow Subbase 17.5"	Downflow Subbase 21"	Propane Gas Conversion Kit
ADS80453ANA	X					X	X		X	X			
ADS80703ANA	X					X	X		X	X			
ADS80904BNA	X					X	X		X		X		
ADS81155CNA	X					X	X		X			X	
ADV80703BX	X	X	X					X					X
ADV80905CX	X	X	X					X					X
ADV81155CX	X	X	X					X					X
AMH80453ANA	X					(5)	X						X
AMH80703ANA	X					(5)	X						X
AMH80704BNA	X					(5)	X						X
AMH80903BNA	X					(5)	X						X
AMH80904BNA	X					(5)	X						X
AMH80905CNA	X					(5)	X						X
AMH81155CNA	X					(5)	X						X
AMH81405DNA	X					(5)	X						X
AMS80453ANA	X					X	X		X				
AMS80703ANA	X					X	X		X				
AMS80704BNA	X					X	X		X				
AMS80903BNA	X					X	X		X				
AMS80904BNA	X					X	X		X				
AMS80905CNA	X					X	X		X				
AMS81155CNA	X					X	X		X				
AMS81405DNA	X					X	X		X				
AMV80704BXA	X	X	X	X				X					X
AMV80905CXA	X	X	X	X				X					X
AMV81155CXA	X	X	X	X				X					X
DMS80453ANA	X					X	X		X				
DMS80703ANA	X					X	X		X				
DMS80704BNA	X					X	X		X				
DMS80904BNA	X					X	X		X				
DMS80905CNA	X					X	X		X				
DMS81155CNA	X					X	X		X				
DMS81405DNA	X					X	X		X				
DDS80453AXA	X					X	X		X	X			
DDS80703AXA	X					X	X		X	X			
DDS80904BXA	X					X	X		X		X		
DDS81155CXA	X					X	X		X			X	
DHS80453AXA	X					X	X		X				
DHS80704BXA	X					X	X		X				
DHS80905CXA	X					X	X		X				

X - Available for this model (1) Up to 7,000 ft. (2) 7,001 to 11,000 ft. (3) 7,001 to 9,000 ft.
 □ Not used in this application. (4) 9,001 to 11,000 ft. (5) MUST use single stage thermostat with FTK03A
 Note: All installations above 7,000 ft. require a pressure switch change.

ACCESSORIES

GOODMAN® BRAND 80% FURNACE ACCESSORIES

Model Number	AFE180-80A	GMU	GSAS	DEHUM1	EFR01	FTK03A	HA02	LPM-03B	LPT-00A	SBT14	SBT17	SBT21	LPM-05
Description	Fossil Fuel Kit	Media Air Cleaners	Electronic Air Cleaner	Dehumidistat	External Filter Rack	Furnace Twinning Kit	High Altitud Natural Gas Kit	Propane Gas Conversion Kit	Propane Gas Conversion Kit	Downflow Subbase 14"	Downflow Subbase 17.5"	Downflow Subbase 21"	Propane Gas Conversion Kit
GDS80453ANA	X					X	X		X	X			
GDS80703ANA	X					X	X		X	X			
GDS80904BNA	X					X	X		X		X		
GDS81155CNA	X					X	X		X			X	
GDH80453AXA	X					(5)	X		X	X			X
GDH80703AXA	X					(5)	X		X	X			X
GDH80904BXA	X					(5)	X		X		X		X
GDH81155CXA	X					(5)	X		X			X	X
GHS80453A*A	X					X	X		X				
GHS80704C*A	X					X	X		X				
GHS80703B*A	X					X	X		X				
GME80704BX*	X					X	X	X	X				
GME80905CX*	X					X	X	X	X				
GME81155CX*	X					X	X	X	X				
GMH80453ANA	X					(5)	X						X
GMH80453AXA	X					(5)	X						X
GMH80703ANA	X					(5)	X						X
GMH80703AXA	X					(5)	X						X
GMH80704BNA	X					(5)	X						X
GMH80704BXA	X					(5)	X						X
GMH80903BNA	X					(5)	X						X
GMH80904BNA	X					(5)	X						X
GMH80904BXA	X					(5)	X						X
GMH80905CNA	X					(5)	X						X
GMH80905CXA	X					(5)	X						X
GMH81155CNA	X					(5)	X						X
GMH81155CXA	X					(5)	X						X
GMH81405DNA	X					(5)	X						X
GMH81405DXA	X					(5)	X						X
GMS80453ANA	X					X	X		X				
GMS80703ANA	X					X	X		X				
GMS80704BNA	X					X	X		X				
GMS80903BNA	X					X	X		X				
GMS80904BNA	X					X	X		X				
GMS80905CNA	X					X	X						
GMS81155CNA	X					X	X						
GMS81405DNA	X					X	X						
GMV80704BXA	X	X	X	X				X					X
GMV80905CXA	X	X	X	X				X					X
GMV81155CXA	X	X	X	X				X					X

X - Available for this model (1) Up to 7,000 ft. (2) 7,001 to 11,000 ft. (3) 7,001 to 9,000 ft.
 □ Not used in this application. (4) 9,001 to 11,000 ft. (5) MUST use single stage thermostat with FTK03A
 Note: All installations above 7,000 ft. require a pressure switch change.

ACCESSORIES

AMANA® BRAND & AMANA® DISTINCTIONS™ BRAND 90% & 95% Furnace Accessories

Model Number	AFE180-60A	AMU	ASAS	CFB17	CFB21	CFB24	DCVK-20	DCVK-30	DEHUM1	EFR01	FTK03A	HALP10	HALP11	HANG11	HANG12	HANG13	HANG14	HAPS27	HAPS28	HAPS29	LPLP01	LPM-03B	LPM-05	LPT-00A
Description	Fossil Fuel Kit	Media Air Cleaners	Electronic Air Cleaner	Downflow Subbase 17.5"	Downflow Subbase 21"	Downflow Subbase 24"	Concentric Vent Kit (2")	Concentric Vent Kit (3")	Dehumidistat	External Filter Rack	Furnace Twinning Kit	High Altitude Propane Gas Kit	High Altitude Propane Gas Kit	High Altitude Natural Gas Kit	High Altitude Natural Gas Kit	High Altitude Natural Gas Kit	High Altitude Natural Gas Kit	High Altitude Pressure Switch	High Altitude Pressure Switch	High Altitude Pressure Switch	Propane Low Pressure Switch	Propane Gas Conversion Kit	Propane Gas Conversion Kit	Propane Gas Conversion Kit
ACS90453BXA	X	X	X	X			X				X	(4)		(1)	(2)			(4)			X			X
ACS90703BXA	X	X	X	X			X				X	(4)		(1)	(2)			(4)			X			X
ACS90704CXA	X	X	X		X		X				X	(4)		(1)	(2)			(4)			X			X
ACS90904CXA	X	X	X		X		X	X			X	(4)		(1)	(2)			(4)			X			X
ACS90905DXA	X	X	X			X	X	X			X	(4)		(1)	(2)			(4)			X			X
ACS91155DXA	X	X	X			X		X			X	(4)		(1)	(2)			(4)			X			X
AMH950453BXA		X	X				X	X		X	(5)	(2)									X			X
AMH950703BXA		X	X				X	X		X	(5)	(2)									X			X
AMH950704CXA		X	X					X		X	(5)	(2)									X			X
AMH950904CXA		X	X					X		X	(5)	(2)									X			X
AMH950905DXA		X	X					X		X	(5)	(2)									X			X
AMH951155DXA		X	X					X		X	(5)	(2)									X			X
AMS90453BXA	X	X	X				X			X	X	(4)		(1)	(2)			(4)			X			X
AMS90703BXA	X	X	X				X			X	X	(4)		(1)	(2)			(4)			X			X
AMS90704CXA	X	X	X				X			X	X	(4)		(1)	(2)			(4)			X			X
AMS90904CXA	X	X	X				X	X		X	X	(4)		(1)	(2)			(4)			X			X
AMS90905DXA	X	X	X				X	X		X	X	(4)		(1)	(2)			(4)			X			X
AMS91155DXA	X	X	X					X		X	X	(4)		(1)	(2)			(4)			X			X
AMS950453BXA		X	X				X	X		X	X	(2)									X			X
AMS950703BXA		X	X				X	X		X	X	(2)									X			X
AMS950704CXA		X	X					X		X	X	(2)									X			X
AMS950905CXA		X	X					X		X	X	(2)									X			X
AMS950905DXA		X	X					X		X	X	(2)									X			X
AMS951155DXA		X	X					X		X	X	(2)									X			X
ACV90704CXA	X	X	X		X		X		X												X	X	X	
ACV90905DXA	X	X	X			X	X	X	X												X	X	X	
AMV90453BXA	X	X	X				X		X	X		(2)				(3)	(4)		(2)		X	X	X	
AMV90704CXA	X	X	X				X		X	X		(2)				(3)	(4)		(2)		X	X	X	
AMV90905DXA	X	X	X				X	X	X	X		(2)				(3)	(4)			(2)	X	X	X	
AMV91155DXA	X	X	X					X	X	X		(2)				(3)	(4)			(2)	X	X	X	
DCS90703BXA	X	X	X	X			X				X	(4)		(1)	(2)			(4)			X			X
DCS90904CXA	X	X	X		X		X	X			X	(4)		(1)	(2)			(4)			X			X
DCS91155DXA	X	X	X			X		X			X	(4)		(1)	(2)			(4)			X			X
DMS90453BXA	X	X	X				X			X	X	(4)		(1)	(2)			(4)			X			X
DMS90703BXA	X	X	X				X			X	X	(4)		(1)	(2)			(4)			X			X
DMS90704CXA	X	X	X				X			X	X	(4)		(1)	(2)			(4)			X			X
DMS90904CXA	X	X	X				X	X		X	X	(4)		(1)	(2)			(4)			X			X
DMS90905DXA	X	X	X				X	X		X	X	(4)		(1)	(2)			(4)			X			X
DMS91155DXA	X	X	X					X		X	X	(4)		(1)	(2)			(4)			X			X

X - Available for this model (1) Up to 7,000 ft. (2) 7,001 to 11,000 ft. (3) 7,001 to 9,000 ft.
 □ Not used in this application. (4) 9,001 to 11,000 ft. (5) MUST use single stage thermostat with FTK03A
 Note: All installations above 7,000 ft. require a pressure switch change.
 Note: For installations in Canada the Goodman 90% furnace is certified only to 4,500 ft.

ACCESSORIES

GOODMAN® BRAND 90% & 95% Furnace Accessories

Model Number	AFE180-60A	GMU	GSAS	CFB17	CFB21	CFB24	DCVK-20	DCVK-30	0170K00000S	DEHUM1	EFR01	FTK03A	HALP10	HALP11	HALP13	HANG11	HANG12	HANG13	HANG14	HANG16	HAPS27	HAPS28	HAPS29	HAPS31	LPLP01	LPM-03B	LPT-00A	LPM-05	RF000180	RF000181
Description	Fossil Fuel Kit	Media Air Cleaners	Electronic Air Cleaner	Downflow Subbase 17.5"	Downflow Subbase 21"	Downflow Subbase 24"	Concentric Vent Kit (2')	Concentric Vent Kit (3')	Concentric Side Wall Vent Kit (3")	Dehumidistat	External Filter Rack	Furnace Twinning Kit	High Altitude Propane Gas Kit	High Altitude Propane Gas Kit	High Altitude Propane Gas Kit	High Altitude Natural Gas Kit	High Altitude Natural Gas Kit	High Altitude Natural Gas Kit	High Altitude Natural Gas Kit	High Altitude Natural Gas Kit	High Altitude Pressure Switch	High Altitude Pressure Switch	High Altitude Pressure Switch	High Altitude Pressure Switch	Propane Low Pressure Switch	Propane Gas Conversion Kit	Propane Gas Conversion Kit	Propane Gas Conversion Kit	Internal Filter Retention Kit (Upflow/Horiz)	Internal Filter Retention Kit (Downflow)
GCH90453BXA	X	X	X				X	X	X		(5)	(2)			(3)	(4)				(2)				X			X			
GCH90703BXA	X	X	X				X	X	X		(5)	(2)			(3)	(4)				(2)				X			X			
GCH90704CXA	X	X	X					X	X		(5)	(2)			(3)	(4)				(2)				X			X			
GCH90904CXA	X	X	X					X	X		(5)	(2)			(3)	(4)				(2)				X			X			
GCH90905CXA	X	X	X					X	X		(5)	(2)			(3)	(4)				(2)				X			X			
GCH91155DXA	X	X	X					X	X		(5)	(2)			(3)	(4)				(2)				X			X			
GCS90453BXA	X	X	X	X			X		X		X	(2)			(1)	(4)				(2)				X		X			X	
GCS90703BXA	X	X	X	X			X		X		X	(2)			(3)	(4)				(2)				X		X			X	
GCS90904CXA	X	X	X		X			X	X		X	(2)			(3)	(4)				(2)				X		X			X	
GCS91155DXA	X	X	X			X		X	X		X	(2)			(3)	(4)				(2)				X		X			X	
GKS90453BXA*	X	X	X				X		X		X	(3)			(1)	(2)								X	X					
GKS90703BXA*	X	X	X				X		X		X	(3)			(1)	(2)								X	X					
GKS90704CXA*	X	X	X				X		X		X	(3)			(1)	(2)								X	X					
GKS90904CXA*	X	X	X					X	X		X	(3)			(1)	(2)								X	X					
GKS90905DXA*	X	X	X					X	X		X	(3)			(1)	(2)								X	X					
GKS91155DXA*	X	X	X					X	X		X	(3)			(1)	(2)								X	X					
GMH950453BXA	X	X	X	X			X	X	X		X	(5)												X			X			
GMH950703BXA	X	X	X	X			X	X	X		X	(5)												X			X			
GMH950704CXA	X	X	X	X				X	X		X	(5)												X			X			
GMH950904CXA	X	X	X					X	X		X	(5)												X			X			
GMH950905DXA	X	X	X					X	X		X	(5)												X			X			
GMH951155DXA	X	X	X					X	X		X	(5)												X			X			
GMS90453BXA	X	X	X				X		X		X	(2)			(3)	(4)				(2)				X		X			X	
GMS90703BXA	X	X	X				X		X		X	(2)			(3)	(4)				(2)				X		X			X	
GMS90904CXA	X	X	X					X	X		X	(2)			(3)	(4)				(2)				X		X			X	
GMS91155DXA	X	X	X					X	X		X	(2)			(3)	(4)				(2)				X		X			X	
GMS950453BXA	X	X	X				X		X		X	(2)			(3)	(4)				(2)				X		X			X	
GMS950703BXA	X	X	X				X		X		X	(2)			(3)	(4)				(2)				X		X			X	
GMS950904CXA	X	X	X					X	X		X	(2)			(3)	(4)				(2)				X		X			X	
GMS951155DXA	X	X	X					X	X		X	(2)			(3)	(4)				(2)				X		X			X	
GCV90704CXA	X	X	X		X		X	X	X	X				(2)						(2)				(2)	X	(1)		(1)		
GCV90905DXA	X	X	X			X		X	X	X			(2)							(2)				(2)	X	(1)		(1)		
GMV90703BXA	X	X	X				X	X	X	X			(2)				(3)	(4)		(2)				X	(1)		(1)			
GMV90905CXA	X	X	X				X	X	X	X		(2)				(3)	(4)			(2)				X	(1)		(1)			
GMV91155DXA	X	X	X					X	X	X		(2)				(3)	(4)			(2)				X	(1)		(1)			
GMV950453BXA	X	X	X				X		X	X		(2)				(3)	(4)			(2)				X	(1)		(1)			
GMV950704CXA	X	X	X					X	X	X		(2)				(3)	(4)			(2)				X	(1)		(1)			
GMV950905DXA	X	X	X					X	X	X		(2)				(3)	(4)			(2)				X	(1)		(1)			
GMV951155DXA	X	X	X					X	X	X		(2)				(3)	(4)			(2)				X	(1)		(1)			

X - Available for this model (1) Up to 7,000 ft. (2) 7,001 to 11,000 ft. (3) 7,001 to 9,000 ft.
 □ Not used in this application. (4) 9,001 to 11,000 ft. (5) MUST use single stage thermostat with FTK03A
 Note: All installations above 7,000 ft. require a pressure switch change.
 Note: For installations in Canada the Goodman 90% furnace is certified only to 4,500 ft.

OPERATING INSTRUCTIONS

FOR YOUR SAFETY READ BEFORE OPERATING

WARNING: If you do not follow these instructions explosion may result causing property damage, personal injury or loss of life.

- A. This appliance does not have a pilot. It is equipped with an ignition device which automatically lights the burner. Do **not** try to light the burner by hand.
- B. **BEFORE OPERATING** smell all around the appliance area for gas. Be sure to smell next to the floor because some gas is heavier than air and will settle on the floor.
- WHAT TO DO IF YOU SMELL GAS**
- Do not try to light any appliance.
 - Do not touch any electric switch; do not use any phone in your building.
 - Immediately call your gas supplier from a neighbor's phone. Follow the gas supplier's instructions.
 - If you cannot reach your gas supplier, call the fire department.
- C. Use only your hand to push in or turn the gas control lever. Never use tools. If the lever will not push in or turn by hand, don't try to repair it, call a qualified service technician. Force or attempted repair may result in a fire or explosion.
- D. Do not use this appliance if any part has been underwater. Immediately call a qualified service technician to inspect the appliance and to replace any part of the control system and any gas control which has been underwater.

LIRE AVANT DE METTRE EN MARCHÉ

AVERTISSEMENT: Quiconque ne respecte pas à la lettre les instructions dans le présent manuel risque de déclencher un incendie ou une explosion entraînant des dommages matériels, des lésions corporelles ou la perte de vies humaines.

- A. Cet appareil ne comporte pas de veilleuse. Il est muni d'un dispositif d'allumage qui allume automatiquement le brûleur. Ne **pas** tenter d'allumer le brûleur manuellement.
- B. **AVANT DE LE FAIRE FONCTIONNER**, renifler tout autour de l'appareil pour déceler une odeur de gaz. Renifler près du plancher, car certains gaz sont plus lourds que l'air et peuvent s'accumuler au niveau du sol.
- QUE FAIRE S'IL Y A UNE ODEUR DE GAZ**
- Ne pas tenter d'allumer l'appareil
 - Ne toucher aucun interrupteur électrique; n'utiliser aucun téléphone dans le bâtiment.
 - Appeler immédiatement le fournisseur de gaz en employant le téléphone d'un voisin. Respecter à la lettre les instructions du fournisseur de gaz.
 - Si personne ne répond, appeler le service des incendies.
- C. Ne pousser ou tourner le levier d'admission du gaz qu'à la main; ne jamais employer d'outil à cet effet. Si la manette reste coincée, ne pas tenter de la réparer; appeler un technicien qualifié. Quiconque tente de forcer la manette ou de la réparer peut déclencher une explosion ou un incendie.
- D. Ne pas se servir de cet appareil s'il a été plongé dans l'eau, complètement ou en partie. Appeler un technicien qualifié pour inspecter l'appareil et remplacer toute partie du système de contrôle et toute commande qui ont été plongés dans l'eau.

OPERATING INSTRUCTIONS

1. **STOP!** Read the safety information above on this label.
2. Set the thermostat to lowest setting.
3. Turn off all power to the appliance.
4. This appliance is equipped with an ignition device which automatically lights the burner. Do **not** try to light the burner by hand.
5. Push the gas control lever to "OFF" Position. Do **not** force.
6. Wait five (5) minutes to clear out any gas. Then smell for gas, including near the floor. If you then smell gas, **STOP!** Follow "B" in the safety. Information above on this label if you don't smell gas, go to next step.
7. Push gas control lever to "ON".
8. Replace access panel.
9. Turn on all electric power to the appliance.
10. Set thermostat to desired setting.
11. If the appliance will not operate, follow the instructions "To Turn Off Gas To Appliance" and call your service technician or gas company.

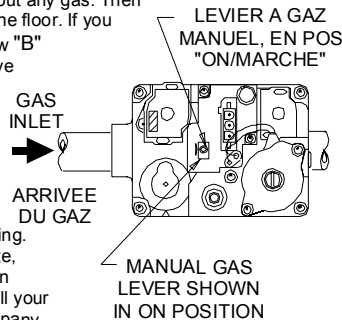

MISE EN MARCHÉ

1. **ARRÊTÉR!** Lisez les instructions de sécurité sur la portion supérieure de cette étiquette.
2. Régler le thermostat à la température la plus basse
3. Couper l'alimentation électrique de l'appareil.
4. Cet appareil ménager étant doté d'un système d'allumage automatique, ne **pas** essayer à allumer le brûleur manuellement.
5. Pousse le levier du contrôle du gaz à "OFF/ ARRÊT" position.
6. Attendre cinq (5) minutes pour laisser échapper tout le gaz. Renifler tout autour de l'appareil, y compris près du plancher, pour déceler une odeur de gaz. Si c'est le cas, **ARRÊTER!** Passer à l'étape B des instructions de sécurité sur la portion supérieure de cette étiquette. S'il n'y a pas d'odeur de gaz, passer à l'étape suivante.
7. Pousse le levier du contrôle du gaz à "ON/MARCHE" position.
8. Remettre en place le panneau d'accès.
9. Mettre l'appareil sous tension.
10. Régler le thermostat à la température désirée.
11. Si l'appareil ne se met pas en marche, suivre les instructions intitulées. Comment couper l'admission de gaz de l'appareil et appeler un technicien qualifié ou le fournisseur de gaz.

TO TURN OFF GAS TO APPLIANCE

1. Set the thermostat to lowest setting.
2. Turn off all electric power to the appliance if service is to be performed.
3. Push the gas control lever to "OFF" Position. Do not force.
4. Replace control access panel.

POUR COUPER L'ADMISSION DE GAZ DE L'APPAREIL

1. Régler le thermostat à la température la plus basse.
2. Couper l'alimentation électrique de l'appareil s'il faut procéder à des opérations d'entretien.
3. Pousse le levier du contrôle du gaz à "OFF / ARRÊT" position. Ne pas forcer.
4. Remettre en place le panneau d'accès.

OPERATING INSTRUCTIONS

FOR YOUR SAFETY READ BEFORE OPERATING

WARNING: If you do not follow these instructions explosion may result causing property damage, personal injury or loss of life.

- A. This appliance does not have a pilot. It is equipped with an ignition device which automatically lights the burner. Do **not** try to light the burner by hand.
- B. **BEFORE OPERATING** smell all around the appliance area for gas. Be sure to smell next to the floor because some gas is heavier than air and will settle on the floor.
- WHAT TO DO IF YOU SMELL GAS**
- Do not try to light any appliance.
 - Do not touch any electric switch; do not use any phone in your building.
 - Immediately call your gas supplier from a neighbor's phone. Follow the gas supplier's instructions.
 - If you cannot reach your gas supplier, call the fire department.
- C. Use only your hand to push in or turn the gas control lever. Never use tools. If the lever will not push in or turn by hand, don't try to repair it, call a qualified service technician. Force or attempted repair may result in a fire or explosion.
- D. Do not use this appliance if any part has been underwater. Immediately call a qualified service technician to inspect the appliance and to replace any part of the control system and any gas control which has been underwater.

LIRE AVANT DE METTRE EN MARCHÉ

AVERTISSEMENT: Quiconque ne respecte pas à la lettre les instructions dans le présent manuel risque de déclencher un incendie ou une explosion entraînant des dommages matériels, des lésions corporelles ou la perte de vies humaines.

- A. Cet appareil ne comporte pas de veilleuse. Il est muni d'un dispositif d'allumage qui allume automatiquement le brûleur. Ne **pas** tenter d'allumer le brûleur manuellement.
- B. **AVANT DE LE FAIRE FONCTIONNER**, renifler tout autour de l'appareil pour détecter une odeur de gaz. Renifler près du plancher, car certains gaz sont plus lourds que l'air et peuvent s'accumuler au niveau du sol.
- QUE FAIRE S'IL Y A UNE ODEUR DE GAZ**
- Ne pas tenter d'allumer l'appareil
 - Ne toucher aucun interrupteur électrique; n'utiliser aucun téléphone dans le bâtiment.
 - Appeler immédiatement le fournisseur de gaz en employant le téléphone d'un voisin. Respecter à la lettre les instructions du fournisseur de gaz.
 - Si personne ne répond, appeler le service des incendies.
- C. Ne pousser ou tourner le levier d'admission du gaz qu'à la main; ne jamais employer d'outil à cet effet. Si la manette reste coincée, ne pas tenter de la réparer; appeler un technicien qualifié. Quiconque tente de forcer la manette ou de la réparer peut déclencher une explosion ou un incendie.
- D. Ne pas se servir de cet appareil s'il a été plongé dans l'eau, complètement ou en partie. Appeler un technicien qualifié pour inspecter l'appareil et remplacer toute partie du système de contrôle et toute commande qui ont été plongés dans l'eau.

OPERATING INSTRUCTIONS

1. **STOP!** Read the safety information above on this label.
2. Set the thermostat to lowest setting.
3. Turn off all power to the appliance.
4. This appliance is equipped with an ignition device which automatically lights the burner. Do **not** try to light the burner by hand.
5. Push the gas control lever to "OFF" Position. Do not force.
6. Wait five (5) minutes to clear out any gas. Then smell for gas, including near the floor. If you then smell gas, **STOP!** Follow "B" in the safety information above on this label if you don't smell gas, go to next step.
7. Push gas control lever to "ON".
8. Replace access panel.
9. Turn on all electric power to the appliance.
10. Set thermostat to desired setting.
11. If the appliance will not operate, follow the instructions "To Turn Off Gas To Appliance" and call your service technician or gas company.

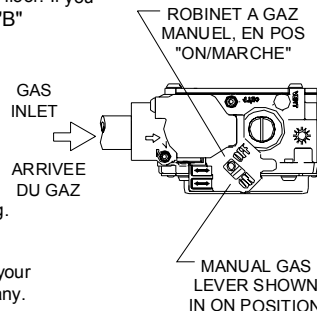

MISE EN MARCHÉ

1. **ARRÊTÉR!** Lisez les instructions de sécurité sur la portion supérieure de cette étiquette.
2. Régler le thermostat à la température la plus basse
3. Couper l'alimentation électrique de l'appareil.
4. Cet appareil ménager étant doté d'un système d'allumage automatique, ne **pas** essayer à allumer le brûleur manuellement.
5. Pousse le levier du contrôle du gaz à "OFF/ ARRÊT" position.
6. Attendre cinq (5) minutes pour laisser échapper tout le gaz. Renifler tout autour de l'appareil, y compris près du plancher, pour détecter une odeur de gaz. Si c'est le cas, **ARRÊTER!** Passer à l'étape B des instructions de sécurité sur la portion supérieure de cette étiquette. S'il n'y a pas d'odeur de gaz, passer à l'étape suivante.
7. Pousse le levier du contrôle du gaz à "ON/MARCHE" position.
8. Remettre en place le panneau d'accès.
9. Mettre l'appareil sous tension.
10. Régler le thermostat à la température désirée.
11. Si l'appareil ne se met pas en marche, suivre les instructions intitulées "Comment couper l'admission de gaz de l'appareil" et appeler un technicien qualifié ou le fournisseur de gaz.

TO TURN OFF GAS TO APPLIANCE

1. Set the thermostat to lowest setting.
2. Turn off all electric power to the appliance if service is to be performed.
3. Push the gas control lever to "OFF" Position. Do not force.
4. Replace control access panel.

POUR COUPER L'ADMISSION DE GAZ DE L'APPAREIL

1. Régler le thermostat à la température la plus basse.
2. Couper l'alimentation électrique de l'appareil s'il faut procéder à des opérations d'entretien.
3. Pousse le levier du contrôle du gaz à "OFF / ARRÊT" position. Ne pas forcer.
4. Remettre en place le panneau d'accès.

11072712

OPERATING INSTRUCTIONS

FOR YOUR SAFETY READ BEFORE OPERATING



WARNING



If you do not follow these instructions exactly, a fire or explosion may result causing property damage, personal injury or loss of life.

A. This appliance does not have a pilot. It is equipped with an ignition device which automatically lights the burners. Do not try to light the burners by hand.

B. BEFORE OPERATING smell around the appliance area for gas. Be sure to smell next to the floor because some gas is heavier than air and will settle on the floor.

WHAT TO DO IF YOU SMELL GAS

- Do not try to light any appliance.
- Do not touch any electric switch; do not use any telephone in your building.
- Immediately call your supplier from a neighbor's phone. Follow the gas suppliers instructions.

- If you cannot reach your gas supplier, call the fire department.

C. Use only your hand to move the gas control switch or knob. Never use tools. If the gas control switch or knob will not operate, don't try to repair it, call a qualified service technician. Force or attempted repair may result in a fire or explosion.

D. Do not use this appliance if any part has been under water. Immediately call a qualified service technician to inspect the appliance and to replace any part of the control system and any gas control which has been under water.

WARNING: Improper installation, adjustment, alteration, service or maintenance can cause injury or property damage. Refer to the user's information manual provided with this furnace. For assistance or additional information consult a qualified installer, service agency or the gas supplier.

This furnace must be installed in accordance with the manufacturers instructions and local codes. In the absence of local codes, follow the National Fuel Gas Code, ANSI Z223.1.

OPERATING INSTRUCTIONS

1. STOP! Read the safety information above on this label.
2. Set the thermostat to lowest setting.
3. Turn off all electric power to the appliance.
4. This appliance is equipped with an automatic ignition system which automatically lights the burners. Do not try to light the burners by hand.
5. Remove control access panel.
6. Move the gas control switch or knob to "OFF".

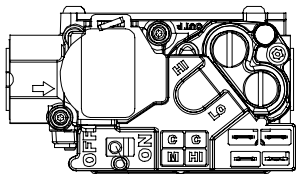

GAS CONTROL SWITCH SHOWN IN "ON" POSITION

7. Wait five (5) minutes to clear out any gas. If you then smell gas, STOP! Follow "B" in the safety information above on this label. If you don't smell gas, go to the next step.
8. Move the gas control switch or knob to "ON".
9. Replace control access panel.
10. Turn on all electric power to the appliance.
11. Set the thermostat to the desired setting.
12. If the appliance will not operate, follow the instructions "To Turn Off Gas To Appliance" and call your service technician or gas supplier.

For indoor installation.

PGB & PGJ
For outdoor installation only.

WARNING: If not installed, operated and maintained in accordance with the manufacturer's instructions, this product could expose you to substances in fuel combustion which can cause death or serious illness and which are known to the State of California to cause cancer, birth defects or other reproductive harm. This product contains fiberglass insulation. Fiberglass insulation contains a chemical known by the State of California to cause cancer.

TO TURN OFF GAS TO APPLIANCE

1. Set the thermostat to its lowest setting.
2. Turn off all electric power to the appliance if service is to be performed.
3. Remove control access panel.
4. Move the gas control switch or knob to "OFF". Do not force.
5. Replace control access panel.

FOR YOUR SAFETY Do not store or use gasoline or other flammable vapors and liquids in the vicinity of this or any other appliance.

0140F0001P

OPERATING INSTRUCTIONS

CONSIGNES DE SÉCURITÉ - LIRE AVANT D'ALLUMER L'APPAREIL

AVERTISSEMENT: Le non-respect des instructions qui suivent peut entraîner un risque d'incendie ou d'explosion causant des dommages, des blessures ou la mort.

A. Cet appareil comporte pas de veilleuse. Il est muni d'un mécanisme qui allume automatiquement le brûleur. N'allumez pas le brûleur manuellement.

B. Sentir tout autour de l'appareil AVANT D'ALLUMER afin de déceler toute fuite de gaz. Assurez-vous de sentir tout près du plancher car certains gaz sont plus lourds que l'air et se déposeront sur le plancher.

SI VOUS SENTEZ UNE ODEUR DE GAZ:

- Ne tentez d'allumer aucun appareil.
- Ne touchez pas aux interrupteurs électriques; n'utiliser aucun téléphone dans l'édifice où vous vous trouvez.
- Appelez immédiatement votre fournisseur de gaz en utilisant le téléphone d'un voisin et suivez les instructions du fournisseur.
- Appelez les pompiers si vous ne parvenez pas à rejoindre votre fournisseur de gaz.

C. N'utiliser que votre main pour pousser ou tourner le commande du gaz. N'utilisez jamais d'outils. Si vous ne parvenez pas à pousser ou à tourner la commande, ne tentez pas de la réparer; appelez un réparateur qualifié. Forcer la commande ou essayer de la réparer peut entraîner un risque d'incendie ou d'explosion.

D. N'utilisez pas cet appareil si l'une de ses parties a été dans l'eau. Si cela se produit, demandez immédiatement à un réparateur qualifié d'inspecter l'appareil et de remplacer toute pièce du système de contrôle et toute commande de gaz ayant été dans l'eau.

0140F00002P

INSTRUCTIONS DE SERVICE

1. UN INSTANT! Lisez d'abord les consignes de sécurité ci-dessus.
2. Réglez le thermostat à son point le plus bas.
3. Coupez l'alimentation électrique de l'appareil.
4. Cet appareil est muni d'un mécanisme qui allume automatiquement le brûleur. Ne tentez pas d'allumer le brûleur manuellement.
5. Retirez le panneau d'accès de la commande.
6. Mettez la commande de gaz à la position ARRÊT ("OFF").
7. Attendez cinq (5) minutes afin de permettre à tout gaz présent d'être évacué. Si vous sentez une odeur de gaz à ce moment, ARRÊTÉZ! et suivez les consignes de sécurité données au paragraphe B ci-dessus. Si vous ne sentez pas de gaz, passez à l'étape suivante.
8. Mettez la commande de gaz à la position MARCHÉ ("ON").
9. Remettez le panneau d'accès de la commande en place.
10. Rétablissez l'alimentation électrique de l'appareil.
11. Réglez le thermostat à la température désirée.
12. Si l'appareil ne fonctionne pas, suivez les instructions intitulées "Arrêt du gaz" et appelez un réparateur qualifié ou votre fournisseur de gaz.

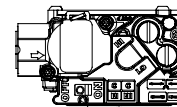

Commande de gaz en position "MARCHÉ"

ARRÊT DU GAZ

1. Réglez le thermostat à son point le plus bas.
2. Coupez l'alimentation électrique de l'appareil si vous devez effectuer un entretien.
3. Retirez le panneau d'accès de la commande.
4. Mettez la commande de gaz à la position ARRÊT ("OFF").
5. Remettez le panneau d'accès de la commande en place.

ACCESSORIES

EXTERNAL FILTER RACK KIT (EFR01)

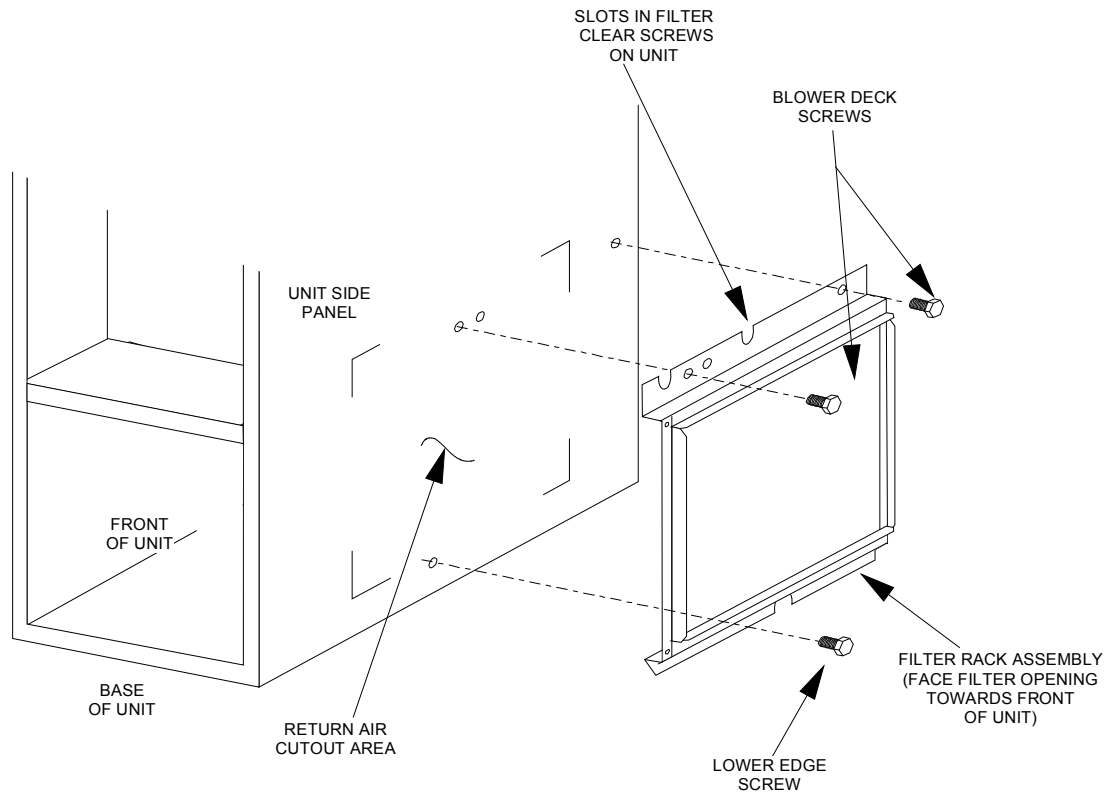

EFR01 EXTERNAL FILTER RACK KIT
Used on Models
90% Upflow Model Furnaces

ACCESSORIES

INTERNAL FILTER RETENTION KIT

RF000180

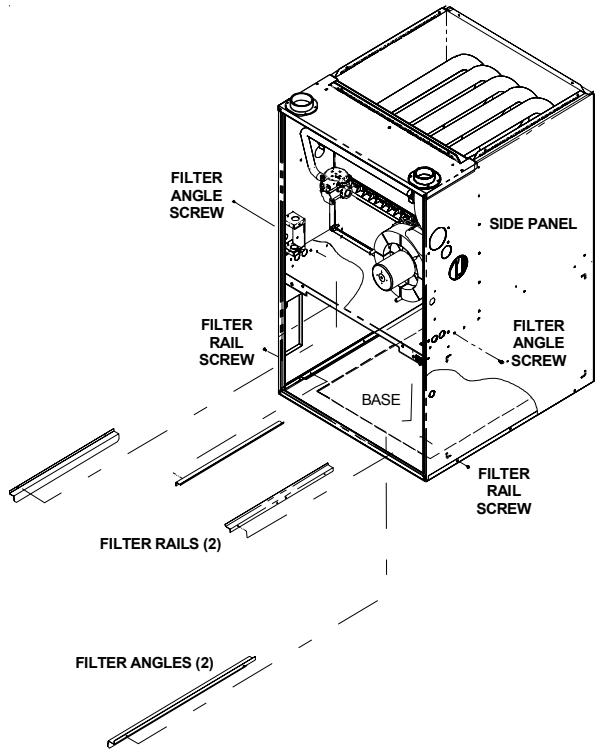

RF000181

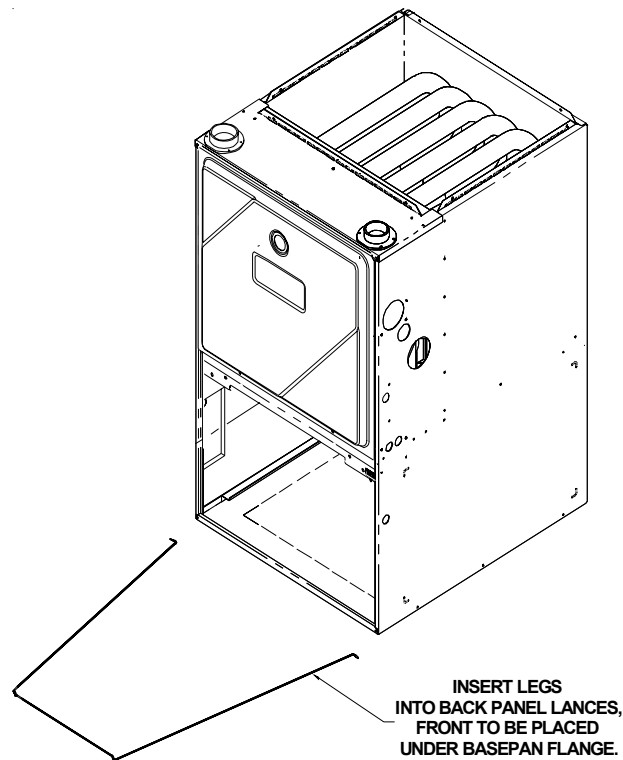
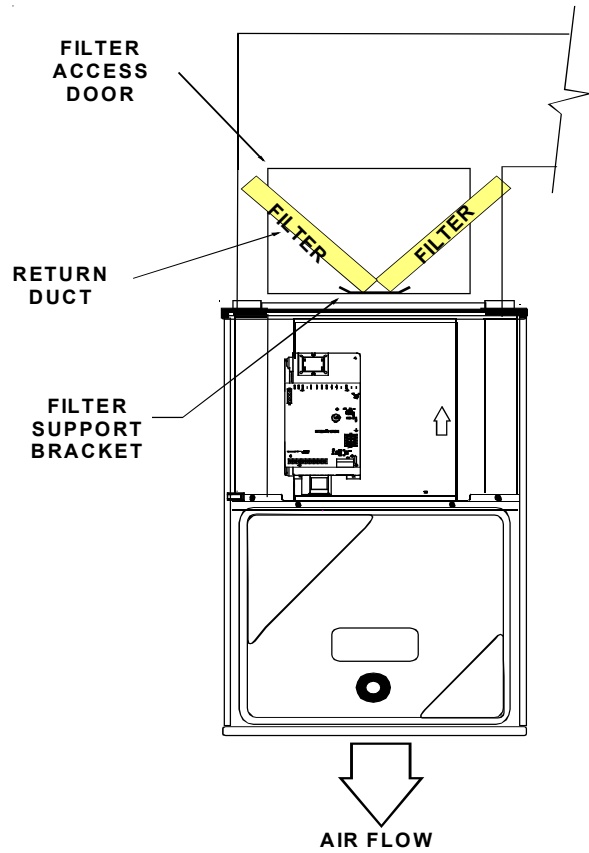

RF000180

Quantity	Part #	Description
20	10690301	Filter Angle
20	20242801	Filter Rail
10	20178501	Filter Retainer
80	M0211216	Screw
1	20512701	Installation Instructions

RF000181

Quantity	Part #	Description
10	10368501	Filter Bracket
20	M0211216	Screws
1	20512701	Installation Instructions

Each "RF" contains enough components to make (10) filter kits.

ACCESSORIES

CONCENTRIC VENT CONVERSION KIT (DCVK-20 ♦ DCVK-30)

The DCVK-20 (2") or the DCVK-30 (3") is a new concentric vent kit approved with furnaces listed in this manual.

This concentric vent kit allows for vertical or horizontal vent termination. The illustrations give a brief view of the kit and its application. See the section in this manual under "Vent Flue and Combustion Air Pipe Terminations" for more information or consult the Installation and Operating Instructions (IO-619B).

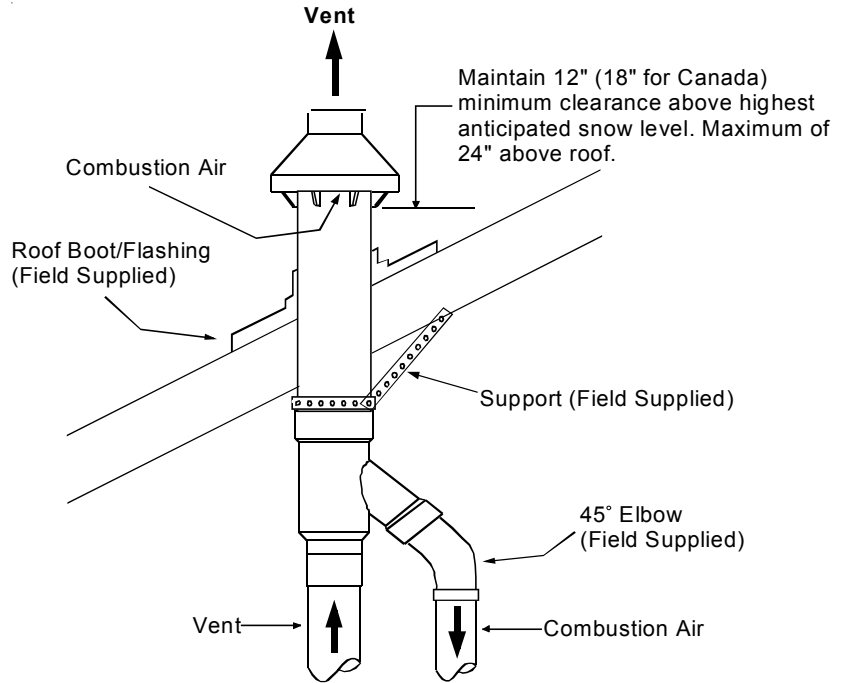

DCVK

(Vertical Installation)

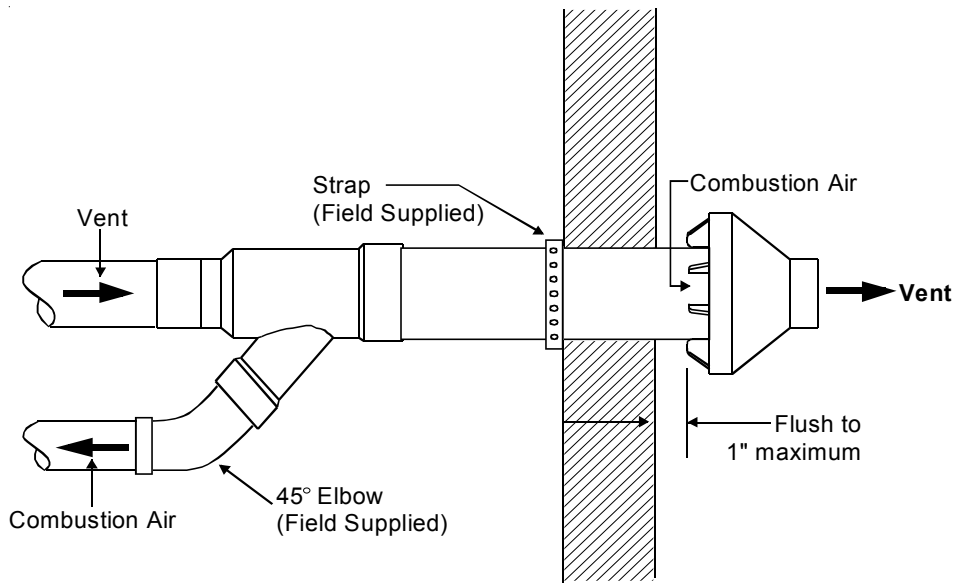

DCVK

(Horizontal Installation)

PRODUCT IDENTIFICATION

SIDE WALL VENT KIT (0170K00000S)

Description

This side wall only vent kit #0170K00000S is to be used with 2" or 3" vent systems. This kit is **NOT intended** for use with single pipe (indirect vent) installations.

The vent kit must terminate outside the structure and may be installed with the intake and exhaust pipes located side-by-side or with one pipe above the other.

See the section in this manual under "Vent Flue and Combustion Air Pipe Terminations" for more information or consult the Installation Instructions (IO-635).

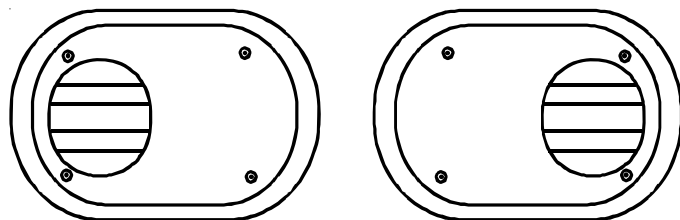
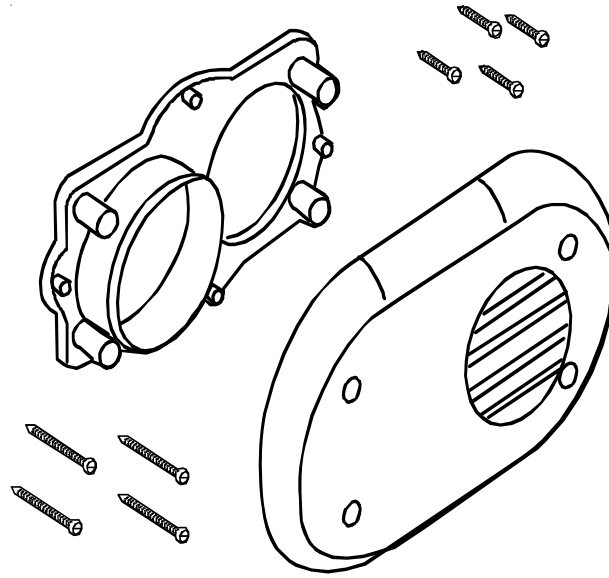

Horizontal Installation

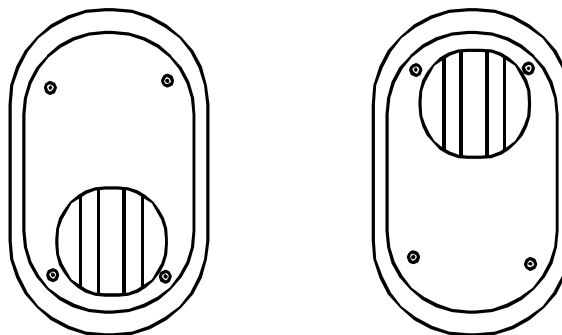

Vertical Installation

ACCESSORIES

CONCENTRIC VENT CONVERSION KIT (HCVK ♦ VCVK)

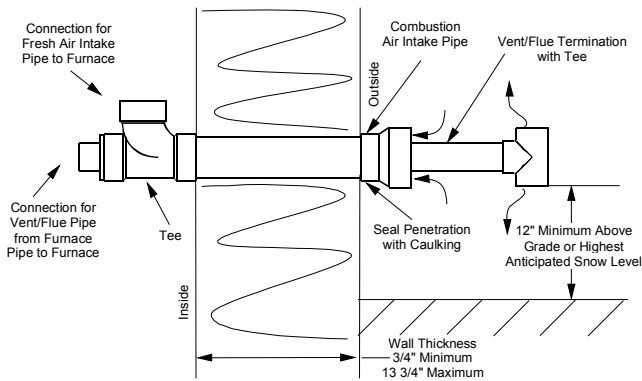
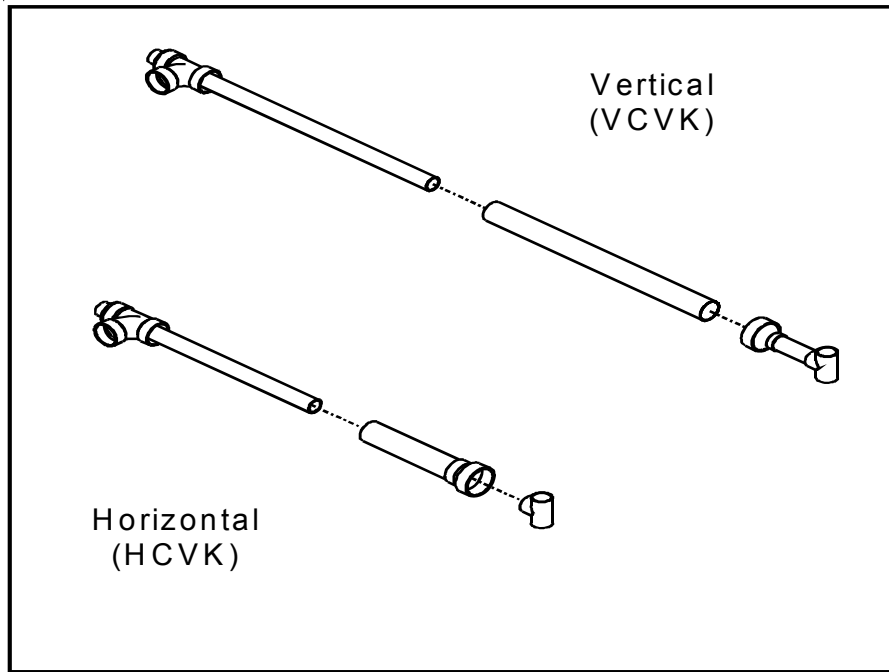

HVCK Installation

Concentric Vents Kits HVCK and VCVK are suitable for use with the 90% efficient furnace products listed in this manual.

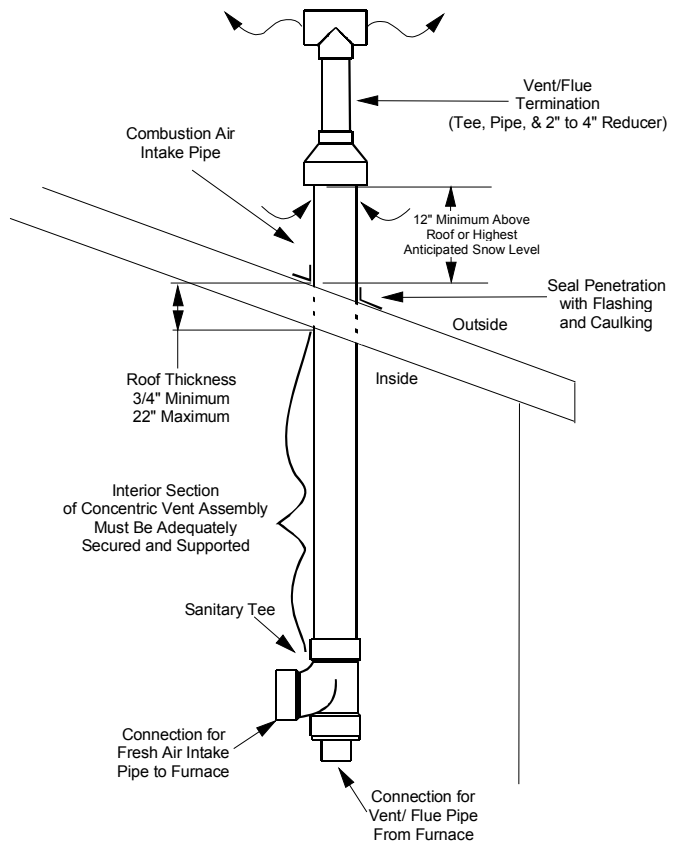

VCVK Installation

PRODUCT DESIGN

Safety

Please adhere to the following warnings and cautions when installing, adjusting, altering, servicing, or operating the furnace.

WARNING

TO PREVENT PERSONAL INJURY OR DEATH DUE TO IMPROPER INSTALLATION, ADJUSTMENT, ALTERATION, SERVICE OR MAINTENANCE, REFER TO THIS MANUAL. FOR ADDITIONAL ASSISTANCE OR INFORMATION, CONSULT A QUALIFIED INSTALLER, SERVICE AGENCY OR THE GAS SUPPLIER.

WARNING

THIS PRODUCT CONTAINS OR PRODUCES A CHEMICAL OR CHEMICALS WHICH MAY CAUSE SERIOUS ILLNESS OR DEATH AND WHICH ARE KNOWN TO THE STATE OF CALIFORNIA TO CAUSE CANCER, BIRTH DEFECTS OR OTHER REPRODUCTIVE HARM.

WARNING

TO PREVENT POSSIBLE PROPERTY DAMAGE, PERSONAL INJURY OR DEATH DUE TO ELECTRICAL SHOCK, THE FURNACE MUST BE LOCATED TO PROTECT THE ELECTRICAL COMPONENTS FROM WATER.

Charge (ESD) Precautions

NOTE: Discharge body's static electricity before touching unit. An electrostatic discharge can adversely affect electrical components.

Use the following precautions during furnace installation and servicing to protect the integrated control module from damage. By putting the furnace, the control, and the person at the same electrostatic potential, these steps will help avoid exposing the integrated control module to electrostatic discharge. This procedure is applicable to both installed and uninstalled (ungrounded) furnaces.

1. Disconnect all power to the furnace. Do not touch the integrated control module or any wire connected to the control prior to discharging your body's electrostatic charge to ground.
2. Firmly touch a clean, unpainted, metal surface of the furnace near the control. Any tools held in a person's hand during grounding will be discharged.
3. Service integrated control module or connecting wiring following the discharge process in Step 2. Use caution not to recharge your body with static electricity; (i.e., do not move or shuffle your feet, do not touch ungrounded objects, etc.). If you come in contact with an ungrounded object, repeat Step 2 before touching control or wires.
4. Discharge any static electricity from your body to ground before removing a new control from its container. Follow Steps 1 through 3 if installing the control on a furnace. Return any old or new controls to their containers before touching any ungrounded object.

Product Application

This product is designed for use as a residential home gas furnace. It is **not** designed or certified for use in mobile home, trailer, or recreational vehicle applications.

This furnace can be used in the following non-industrial commercial applications: **Schools, Office buildings, Churches, Retail stores, Nursing homes, Hotels/motels, Common or office areas.** In such applications, the furnace must be installed with the installation instructions.

The 80% and 90% furnaces are ETL certified appliances and are appropriate for use with natural or propane gas. (**NOTE:** If using propane gas, a propane conversion kit is required).

One important difference between the 80% and 90% furnace is that the 90% furnace is a dual certified appliance.

Dual certification means that the combustion air inlet pipe is optional and the furnace can be vented as a:

Non-direct vent (single pipe) central forced air furnace in which combustion air is taken from the installation area or from air ducted from the outside or,

Direct vent (dual pipe) central forced air furnace in which all combustion air supplied directly to the furnace burners through a special air intake system outlined in this manual and the installation instructions.

IMPORTANT NOTE: The 80% furnace cannot be installed as a direct vent (i.e., sealed combustion) furnace. The burner box is present only to help reduce sound transmission from the burners to the occupied space.

To ensure proper installation, operation and servicing, thoroughly read the installation and service manuals for specifics pertaining to the installation, servicing and application of this product.

WARNING

POSSIBLE PROPERTY DAMAGE, PERSONAL INJURY OR DEATH DUE TO FIRE, EXPLOSION, SMOKE, SOOT, CONDENSATION, ELECTRICAL SHOCK OR CARBON MONOXIDE MAY RESULT FROM IMPROPER INSTALLATION, REPAIR, OPERATION, OR MAINTENANCE OF THIS PRODUCT.

WARNING

TO PREVENT PROPERTY DAMAGE, PERSONAL INJURY OR DEATH DUE TO FIRE, DO NOT INSTALL THIS FURNACE IN A MOBILE HOME, TRAILER, OR RECREATIONAL VEHICLE.

To ensure proper furnace operation, install, operate, maintain and service the furnace in accordance with the installation, operation and service instructions, all local building codes and ordinances. In their absence, follow the latest edition of the National Fuel Gas Code (NFPA 54/ANSI Z223.1), and/or CAN/CGA B149 Installation Codes, local plumbing or waste water codes, and other applicable codes. A copy of the National Fuel Gas Code (NFPA 54/ANSI Z223.1) can be obtained from any of the following:

PRODUCT DESIGN

American National Standards Institute
1430 Broadway
New York, NY 10018

National Fire Protection Association
1 Batterymarch Park
Quincy, MA 02269

CSA International
8501 East Pleasant Valley
Cleveland, OH 44131

A copy of the CAN/CGA B149 Installation Codes can be obtained from:

CSA International
178 Rexdale Boulevard
Etobicoke, Ontario, Canada M9W, 1R3

The rated heating capacity of the furnace should be greater than or equal to the total heat loss of the area to be heated. The total heat loss should be calculated by an approved method or in accordance with "ASHRAE Guide" or "Manual J-Load Calculations" published by the Air Conditioning Contractors of America.

Location Requirements and Considerations



WARNING

TO PREVENT POSSIBLE EQUIPMENT DAMAGE, PROPERTY DAMAGE, PERSONAL INJURY OR DEATH, THE FOLLOWING BULLET POINTS MUST BE OBSERVED WHEN INSTALLING THE UNIT.

Follow the instructions listed below when selecting a furnace location. Refer also to the guidelines provided in the *Combustion and Ventilation Air Requirements* section in this manual or the installation instructions for details.

- Centrally locate the furnace with respect to the proposed or existing air distribution system.
- Ensure the temperature of the return air entering the furnace is between 55°F and 100°F when the furnace is heating.
- Provide provisions for venting combustion products outdoors through a proper venting system. Special consideration should be given to vent/flue pipe routing and combustion air intake pipe when applicable.

80% Furnaces: All installations must be vented in accordance with National Fuel Gas Code, NFPA 54/ANSI Z223.1 - latest edition. In Canada the furnaces must be vented in accordance with the National Standard of Canada, CAN/CGA B149.

90% Furnaces: Refer to the *Vent/Flue Pipe and Combustion Air Pipe - Termination Locations* section in this manual or the installation instructions for appropriate termination locations. Also for 90% furnaces, refer to

the *Vent/Flue Pipe and Combustion Air Pipe - Termination Locations* section in this manual or the installation instructions to determine if the piping system from furnace to termination can be accomplished within the guidelines given. **NOTE:** The length of flue and/or combustion air piping can be a limiting factor in the location of the furnace.

- Locate the 90% furnace so that the condensate can be piped at a downward slope away from the furnace to the drain. Do not locate the furnace or its condensate drainage system in any area subject to below freezing temperatures without proper freeze protection. Refer to the *Condensate Drain Lines and Trap* section in this manual or the installation instructions for further details.
- Set the 90% furnace on a level floor to enable proper condensate drainage. If the floor becomes wet or damp at times, place the furnace above the floor on a concrete base sized approximately 1-1/2" larger than the base of the furnace. Refer to the *Horizontal Applications and Considerations* section in this manual or the installation instructions for leveling of horizontal furnaces.
- Ensure upflow or horizontal furnaces are not installed directly on carpeting, or any other combustible material. The only combustible material allowed is wood.
- A special accessory subbase must be used for upright counterflow unit installations over any combustible material (including wood). Refer to subbase instructions for installation details. (**NOTE:** A subbase will not be required if an air conditioning coil is located beneath the furnace between the supply air opening and the combustible floor.)
- Exposure to contaminated combustion air will result in safety and performance-related problems. Do not install the furnace where the combustion air is exposed to the following substances:
 - chlorinated waxes or cleaners
 - chlorine-based swimming pool chemicals
 - water softening chemicals
 - deicing salts or chemicals
 - carbon tetrachloride
 - halogen type refrigerants
 - cleaning solutions (such as perchloroethylene)
 - printing inks
 - paint removers
 - varnishes
 - hydrochloric acid
 - cements and glues
 - antistatic fabric softeners for clothes dryers
 - and masonry acid washing materials
- Seal off a *non-direct vent* furnace if it is installed near an area frequently contaminated by any of the above substances. This protects the *non-direct vent* furnace from airborne contaminants. To ensure that the en-

PRODUCT DESIGN

closed *non-direct vent* furnace has an adequate supply of combustion air, vent from a nearby uncontaminated room or from outdoors. Refer to the *Combustion and Ventilation Air Requirements* section in this manual or the installation instructions for details.

- If the furnace is used in connection with a cooling unit, install the furnace upstream or in parallel with the cooling unit coil. Premature heat exchanger failure will result if the cooling unit coil is placed ahead of the furnace.
- If the furnace is installed in a residential garage, position the furnace so that the burners and ignition source are located not less than 18 inches (457 mm) above the floor. Protect the furnace from physical damage by vehicles.
- If the furnace is installed horizontally, the furnace access doors must be vertical so that the burners fire horizontally into the heat exchanger. Do not install the unit with the access doors on the “up/top” or “down/bottom” side of the furnace.

Clearances and Accessibility

Installations must adhere to the clearances to combustible materials to which this furnace has been design certified. The minimum clearance information for this furnace is provided on the unit's clearance label. These clearances must be permanently maintained. Refer to Specification Sheet for minimum clearances to combustible materials. Clearances must also accommodate an installation's gas, electrical, and drain trap and drain line connections. If the alternate combustion air intake or vent/flue connections are used on a 90% furnace, additional clearances must be provided to accommodate these connections. Refer to *Vent Flue Pipe and Combustion Air Pipe* section in this manual or the installation instructions for details. **NOTE:** In addition to the required clearances to combustible materials, a minimum of 24 inches service clearance must be available in front of the unit.

A furnace installed in a confined space (i.e., a closet or utility room) must have two ventilation openings with a total minimum free area of 0.25 square inches per 1,000 BTU/hr of furnace input rating. One of the ventilation openings must be within 12 inches of the top; the other opening must be within 12 inches of the bottom of the confined space. In a typical construction, the clearance between the door and door frame is usually adequate to satisfy this ventilation requirement.

Furnace Suspension

If suspending the furnace from rafters or joist, use 3/8" threaded rod and 2"x2"x1/8" angle iron as shown in the following figure. If the furnace is installed in a crawl space it must also be suspended from the floor joist or supported by a concrete pad. Never install the furnace on the ground or allow it to be exposed to water. The length of rod will depend on the application and the clearances necessary.

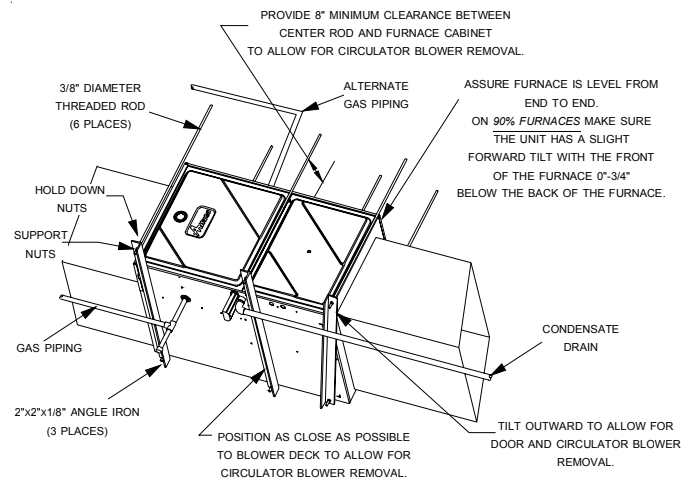

**90% Suspended Furnace Shown
(80% Furnace Similar)**

EXISTING FURNACE REMOVAL

NOTE: When an existing furnace is removed from a venting system serving other appliances, the venting system may be too large to properly vent the remaining attached appliances.

The following vent testing procedure is reproduced from the **American National Standard/National Standard of Canada for Gas-Fired Central Furnaces ANSI Z21.47, latest edition, CSA-2.3b, latest edition Section 1.23.1.**

The following steps shall be followed with each appliance connected to the venting system placed in operation, while any other appliances connected to the venting system are not in operation:

- a. Seal any unused openings in the venting system;
- b. Inspect the venting system for proper size and horizontal pitch, as required by the National Fuel Gas Code, ANSI Z223.1 or the CSA B149 Installation Codes and these instructions. Determine that there is no blockage or restriction, leakage, corrosion and other deficiencies which could cause an unsafe condition;
- c. In so far as practical, close all building doors and windows and all doors between the space in which the appliance(s) connected to the venting system are located and other spaces of the building. Turn on clothes dryers and any appliance not connected to the venting system. Turn on any exhaust fans, such as range hoods and bathroom exhausts, so they shall operate at maximum speed. Do not operate a summer exhaust fan. Close fireplace dampers;
- d. Follow the lighting instructions. Place the appliance being inspected in operation. Adjust thermostat so appliance shall operate continuously;
- e. Test for draft hood equipped spillage at the draft hood relief opening after 5 minutes of main burner operation. Use the flame of a match or candle;
- f. After it has been determined that each appliance connected to the venting system properly vents when tested as outlined above, return doors, windows, exhaust fans, fireplace dampers and any other gas burning appliance to their previous conditions of use;
- g. If improper venting is observed during any of the above tests, the common venting system must be corrected.

PRODUCT DESIGN

Corrections must be in accordance with the latest edition of the National Fuel Gas Code NFPA 54/ANSI Z223.1 and/or CSA B149 Installation Codes.

If resizing is required on any portion of the venting system, use the appropriate table in Appendix G in the latest edition of the National Fuel Gas Code ANSI Z223.1 and/or CSA B149 *Installation Codes*.

Thermostat Requirements

A single-stage furnace requires a single-stage thermostat while the two-stage furnace requires a two-stage thermostat for proper operation (see note below). The single-stage thermostat provides "W1" for only one stage of heat while the two-stage thermostat provides "W1" and a "W2" terminals for control of low stage and high stage heat. Refer to *Electrical Connections - 24 Volt Thermostat Wiring* section in this manual or the installation instructions for correct installation procedure for these thermostats.

NOTE: A single-stage thermostat with only one heating stage can be used to control a two-stage furnace. The application of a single-stage thermostat does not offer "true" thermostat driven two-stage operation, but provides a *timed* transition from low to high fire. The furnace will run on low stage for a fixed period of time before stepping up to high stage to satisfy the thermostat's call for heat. The delay period prior to stepping up can be set at either 5 or 10 minutes through the DIP switch adjacent to the Heat Off delay DIP switches on the integrated control module. To use a single-stage thermostat, turn off power to the furnace, move the thermostat selection jumper on the integrated control module from the "two-stage" position to the "single-stage" position, turn power back on. Refer to the following figures.

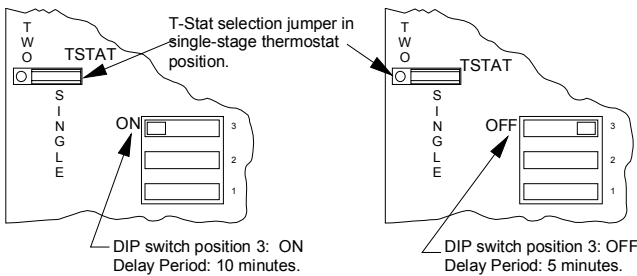

NOTE: The AMH, GCH, GDH, GMH and GME hybrid furnaces **require** a single stage thermostat. These furnaces utilize a control board with single stage or two stage capability. The second stage feature is established by setting a dip switch on the board, either one stage or two stage. All of the second stage timing is then controlled by dipswitch 3 on the circuit board.

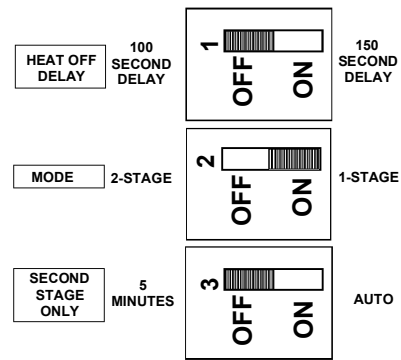

Dehumidistat Requirements

A dehumidistat can be used in conjunction with the two-stage variable speed 80% or 90% furnace to lower the humidity in the conditioned space. The dehumidistat will improve dehumidification of the conditioned air by prompting the furnace to reduce the speed of the circulator blower during operation in the cooling mode. To be compatible with these furnaces, a dehumidistat must operate on 24 VAC and utilize a switch which **opens on humidity rise**. Refer to *Electrical Connections - 24 Volt Dehumidistat Wiring* section in this manual or the installation instructions for correct installation procedure.

Thermostat and Dehumidistat Location

In an area having good air circulation, locate the thermostat and dehumidistat (if applicable) about five feet high on a vibration-free inside wall. Do not install the thermostat or dehumidistat where it may be influenced by any of the following:

- Drafts, or dead spots behind doors, in corners, or under cabinets.
- Hot or cold air from registers.
- Radiant heat from the sun.
- Light fixtures or other appliances.
- Radiant heat from a fireplace.
- Concealed hot or cold water pipes, or chimneys.
- Unconditioned areas behind the thermostat and dehumidistat, such as an outside wall.

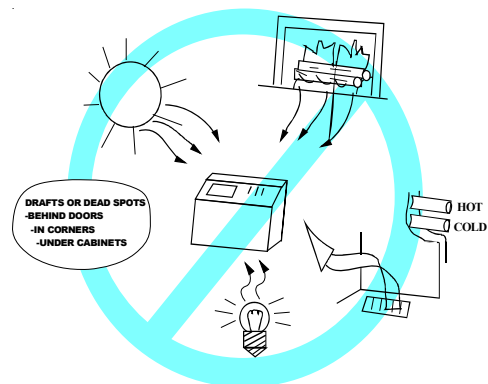

Thermostat Influences

PRODUCT DESIGN

Consult the instructions packaged with the thermostat and dehumidistat for mounting instructions and further precautions.

COMBUSTION AND VENTILATION AIR REQUIREMENTS



WARNING

POSSIBLE PROPERTY DAMAGE, PERSONAL INJURY OR DEATH MAY OCCUR IF THE FURNACE IS NOT PROVIDED WITH ENOUGH FRESH AIR FOR PROPER COMBUSTION AND VENTILATION OF FLUE GASES. MOST HOMES REQUIRE OUTSIDE AIR BE SUPPLIED TO THE FURNACE AREA.

Improved construction and additional insulation in buildings have reduced heat loss by reducing air infiltration and escape around doors and windows. These changes have helped in reducing heating/cooling costs but have created a problem supplying combustion and ventilation air for gas fired and other fuel burning appliances. Appliances that pull air out of the house (clothes dryers, exhaust fans, fireplaces, etc.) increase the problem by starving appliances for air.

If this furnace is to be installed in the same space with other gas appliances, such as a water heater, ensure there is an adequate supply of combustion and ventilation air for the other appliances. Refer to the latest edition of the National Fuel Gas Code NFPA 54/ANSI Z223.1 (Section 9.3), or CAN/CGA B149 Installation Codes (Sections 7.2, 7.3, or 7.4), or applicable provisions of the local building codes for determining the combustion air requirements for the appliances. Most homes will require outside air be supplied to the furnace area by means of ventilation grilles or ducts connecting directly to the outdoors or spaces open to the outdoors such as attics or crawl spaces.

The following information on air for combustion and ventilation is reproduced from the **National Fuel Gas Code NFPA 54/ANSI Z223.1 Section 9.3.**

9.3* Air for Combustion and Ventilation.

9.3.1 General.

9.3.1.1 Air for combustion, ventilation, and dilution of flue gases for appliances installed in buildings shall be obtained by application of one of the methods covered in 9.3.2 through 9.3.6. Where the requirements of 9.3.2 are not met, outdoor air shall be introduced in accordance with methods covered in 9.3.3 through 9.3.6.

Exception No. 1: This provision shall not apply to direct vent appliances.

9.3.1.2 Appliances of other than natural draft design and other than Category 1 vented appliances shall be provided with combustion, ventilation, and dilution air in accordance with the appliance manufacturer's instructions.

9.3.1.3 Appliances shall be located so as not to interfere with proper circulation of combustion, ventilation, and dilution air.

9.3.1.4 Where used, a draft hood or a barometric draft regulator shall be installed in the same room or enclosure as the appliance served so as to prevent any difference in pressure between the hood or regulator and the combustion air supply.

9.3.1.5 Makeup air requirements for the operation of exhaust fans, kitchen ventilation systems, clothes dryers, and fireplaces shall be considered in determining the adequacy of a space to provide combustion air requirements.

9.3.2 Indoor Combustion Air. The required volume of indoor air shall be determined in accordance with the method in 9.3.2.1 or 9.3.2.2 except that where the air infiltration rate is known to be less than 0.40 ACH, the method in 9.3.2.2 shall be used. The total required volume shall be the sum of the required volume calculated for all appliances located within the space. Rooms communicating directly with the space in which the appliances are installed through openings not furnished with doors, and through combustion air openings sized and located in accordance with 9.3.2.3, are considered a part of the required volume.

9.3.2.1* Standard Method. The minimum required volume shall be 50 ft³ per 10000/Btu/hour (4.8m³/kW).

9.3.2.2* Known Air Infiltration Rate Method. Where the air infiltration rate of a structure is known, the minimum required volume shall be determined as follows:

(1) For appliances other than fan-assisted, calculate using the following equation:

$$\text{Required Volume}_{\text{other}} \geq \frac{21 \text{ ft}^3}{ACH} \left(\frac{I_{\text{other}}}{1000 \text{ Btu/hr}} \right)$$

(2) For fan-assisted appliances, calculate using the following equation:

$$\text{Required Volume}_{\text{fan}} \geq \frac{15 \text{ ft}^3}{ACH} \left(\frac{I_{\text{fan}}}{1000 \text{ Btu/hr}} \right)$$

where:

I_{other} = all appliances other than fan-assisted input in Btu per hour

I_{fan} = fan-assisted appliances input in Btu per hour

ACH = air change per hour (percent of volume of space exchanged per hour, expressed as a decimal)

(3) For purposes of this calculation, an infiltration rate greater than 0.60 ACH shall not be used in the equations in 9.3.2.2(1) and 9.3.2.2(2).

9.3.2.3 Indoor Opening Size and Location. Openings used to connect indoor spaces shall be sized and located in accordance with the following:

(1)* *Combining spaces on the same story.* Each opening shall have a minimum free area of 1 in.²/1000Btu/hr (2200 mm²/kW) of the total input rating of all appliances in the space but not less than 100 in.² (0.60m²). One opening shall commence within 12 in. (300 mm) of the top, and one opening shall commence within 12 in. (300 mm) of the bottom, of the enclosure [see Figure A.9.3.2.3(1)]. The minimum dimension of air openings shall be not less than 3 in. (80 mm).

PRODUCT DESIGN

NOTE: Each opening must have a free area of not less than one square inch per 1000 BTU of the total input rating of all equipment in the enclosure, but not less than 100 square inches.

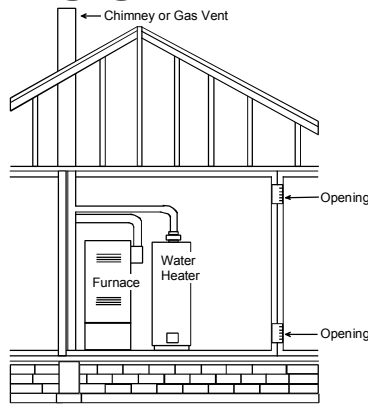

Figure A.9.2.3.3(1) All Combustion Air from Adjacent Indoor Spaces through Indoor Combustion Air Openings.

(2) *Combining spaces in different stories.* The volumes of spaces in different stories shall be considered as communicating spaces where such spaces are connected by one or more openings in doors or floors having a total minimum free area of 2 in.²/1000 Btu/hr (4400 mm²/kW) of total input rating of all appliances.

9.3.3 Outdoor Combustion Air. Outdoor combustion air shall be provided through opening(s) to the outdoors in accordance with the methods in 9.3.3.1 or 9.3.3.2. The minimum dimension of air openings shall not be less than 3 in. (80 mm).

9.3.3.1 Two Permanent Openings Method. Two permanent openings, one commencing within 12 in. (300 mm) of the top and one commencing within 12 in. (300 mm) of the bottom, of the enclosure shall be provided. The openings shall communicate directly, or by ducts, with the outdoors or spaces that freely communicate with the outdoors, as follows:

(1)* Where directly communicating with the outdoors or where communicating to the outdoors through vertical ducts, each opening shall have a minimum free area of 1 in.²/4000 Btu/hr (550 min²/kW) of total input rating of all appliances in the enclosure. [See Figure A.9.3.3.1(1)(a) and Figure A.9.3.3.1(1)(b).]

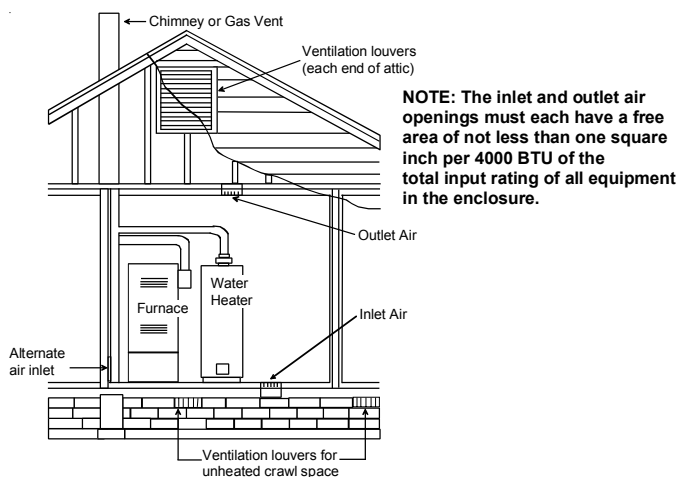

Figure A.9.3.3.1(1)(a) All Combustion Air From Outdoors - Inlet Air from Ventilated Crawl Space and Outlet Air to Ventilated Attic.

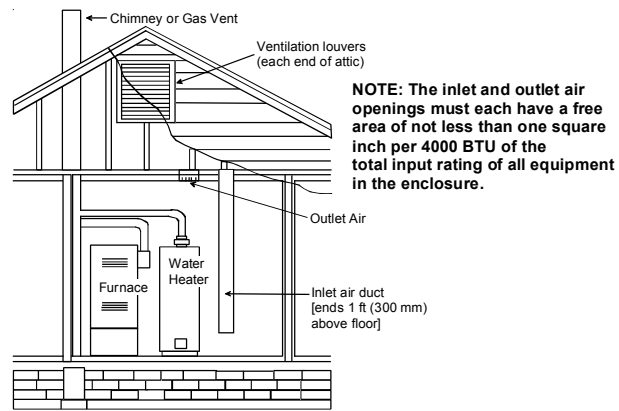

Figure A.9.3.3.1(1)(b) All Combustion Air From Outdoors through Ventilated Attic.

(2)* Where communicating with the outdoors through horizontal ducts, each opening shall have a minimum free area of 1 in.²/2000 Btu/hr (1100 min²/kW) of total input rating of all appliances in the enclosure. [See Figure A.9.3.3.1(2).]

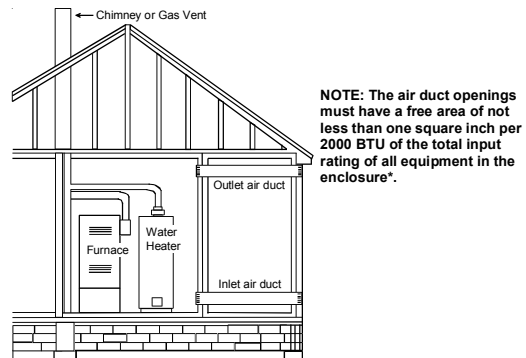

Figure A.9.3.3.1(2) All Combustion Air From Outdoors through Horizontal Ducts.

9.3.3.2* One Permanent Opening Method. One permanent opening, commencing within 12 in. (300 mm) of the top of the enclosure, shall be provided. The appliance shall have clearances of at least 1 in. (25 mm) from the sides and back and 6 in. (150 mm) from the front of the appliance. The opening shall directly communicate to the outdoors or shall communicate through a vertical or horizontal duct to the outdoors or spaces that freely communicate with the outdoors (see Figure A.9.3.3.2) and shall have a minimum free area of the following:

- (1) 1 in.²/3000 Btu/hr (700 mm² per kW) of the total input rating of all appliances located in the enclosure, and
- (2) Not less than the sum of the areas of all vent connectors in the space.

PRODUCT DESIGN

NOTE: The single opening must have a free area of not less than one square inch per 3000 BTU of the total input rating of all equipment in the enclosure, but not less than the sum of the areas of all vent connectors in the confined space.

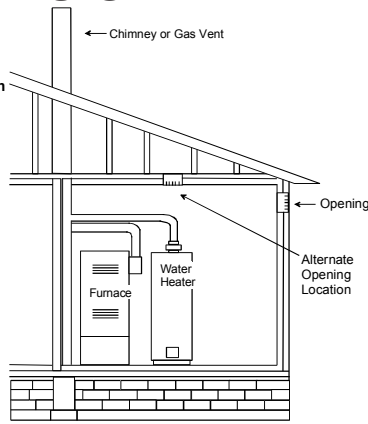

Figure A.9.3.3.2 All Combustion Air From Outdoors through Single Combustion Air Opening.

9.3.4 Combination Indoor and Outdoor Combustion Air. The use of a combination of indoor and outdoor combustion air shall be in accordance with (1) through (3) (*see example calculation in Annex JJ*):

- (1) *Indoor Openings:* Where used, openings connecting the interior spaces shall comply with 9.3.2.3.
- (2) *Outdoor Opening(s) Location.* Outdoor opening(s) shall be located in accordance with 9.3.3.
- (3) *Outdoor Opening(s) Size.* The outdoor opening(s) size shall be calculated in accordance with the following:
 - (a) The ratio of the interior spaces shall be the available volume of all communicating spaces divided by the required volume.
 - (b) The outdoor size reduction factor shall be 1 minus the ratio of interior spaces.
 - (c) The minimum size of outdoor opening(s) shall be the full size of outdoor opening(s) calculated in accordance with 9.3.3, multiplied by the reduction factor. The minimum dimension of air openings shall not be less than 3 in. (80 mm).

9.3.5 Engineered Installations. Engineered combustion air installations shall provide an adequate supply of combustion, ventilation, and dilution air and shall be approved by the authority having jurisdiction.

9.3.6 Mechanical Combustion Air Supply. Where all combustion air is provided by a mechanical air supply system, the combustion air shall be supplied from outdoors at the minimum rate of 0.35 ft³/min per 1000 Btu/hr (0.034 m³/min per kW) for all appliances located within the space.

9.3.6.1 Where exhaust fans are installed, additional air shall be provided to replace the exhausted air.

9.3.6.2 Each of the appliances served shall be interlocked to the mechanical air supply system to prevent main burner operation where the mechanical air supply system is not in operation.

9.3.6.3 Where combustion air is provided by the building's mechanical ventilation system, the system shall provide the specified combustion air rate in addition to the required ventilation air.

9.3.7 Louvers, Grilles, and Screens.

9.3.7.1 Louvers and Grilles. The required size of openings for combustion, ventilation, and dilution air shall be based on the net free area of each opening. Where the free area through a design of louver or grille or screen is known, it shall be used in calculating the size opening required to provide the free area specified. Where the louver and grille design and free area are not known, it shall be assumed that wood louvers will have 25 percent free area, and metal louvers and grilles will have 75 percent free area. Nonmotorized louvers and grilles shall be fixed in the open position.

9.3.7.2 Minimum Scree Mesh Size. Screens shall not be smaller than 1/4 in. mesh.

9.3.7.3 Motorized Louvers. Motorized louvers shall be interlocked with the appliance so they are proven in the full open position prior to main burner ignition and during main burner operation. Means shall be provided to prevent the main burner from igniting should the louver fail to open during burner startup and to shut down the main burner if the louvers close during burner operation.

9.3.8 Combustion Air Ducts. Combustion air ducts shall comply with 9.3.8.1 through 9.3.8.8.

9.3.8.1 Ducts shall be constructed of galvanized steel or a material having equivalent corrosion resistance, strength, and rigidity.

Exception: Within dwellings units, unobstructed stud and joist spaces shall not be prohibited from conveying combustion air, provided that not more than one fireblock is removed.

9.3.8.2 Ducts shall terminate in an unobstructed space, allowing free movement of combustion air to the appliances.

9.3.8.3 Ducts shall serve a single space.

9.3.8.4 Ducts shall not serve both upper and lower combustion air openings where both such openings are used. The separation between ducts servicing upper and lower combustion air openings shall be maintained to the source of combustion air.

9.3.8.5 Ducts shall not be screened where terminating in an attic space.

9.3.8.6 Horizontal upper combustion air ducts shall not slope downward toward the source of combustion air.

9.3.8.7 The remaining space surrounding a chimney liner, gas vent, special gas vent, or plastic piping installed within a masonry, metal, or factory built chimney shall not be used to supply combustion air.

Exception: Direct vent appliances designed for installation in a solid fuel-burning fireplace where installed in accordance with the manufacture's installation instructions.

9.3.8.8 Combustion air intake openings located on the exterior of the building shall have the lowest side of the combustion air intake openings located at least 12 in. (300 mm) vertically from the adjoining grade level.

PRODUCT DESIGN

Category I Venting (Vertical Venting) (80% Furnaces Only)

! WARNING

TO PREVENT POSSIBLE PERSONAL INJURY OR DEATH DUE TO ASPHYXIATION, NON-CONDENSING GAS FIRED WARM AIR FURNACES MUST BE CATEGORY I VENTED. DO NOT VENT ANY OF THESE FURNACES USING CATEGORY III VENTING.

Category I Venting is venting at a non-positive pressure. A furnace vented as Category I is considered a fan-assisted appliance and does not have to be "gas tight." **NOTE:** Single-Stage and Two-Stage gas furnaces with induced draft blowers draw products of combustion through a heat exchanger allowing in some instances common venting with natural draft appliances (i.e. water heaters).

All installations must be vented in accordance with National Fuel Gas Code NFPA 54/ANSI Z223.1 - latest edition. In Canada, the furnaces must be vented in accordance with the National Standard of Canada, CAN/CGA B149.1 and CAN/CGA B149.2 - latest editions and amendments.

NOTE: The vertical height of the Category I venting system must be at least as great as the horizontal length of the venting system.

! WARNING

TO PREVENT POSSIBLE DEATH OR PERSONAL INJURY DUE TO ASPHYXIATION, COMMON VENTING WITH OTHER MANUFACTURER'S INDUCED DRAFT APPLIANCES IS NOT ALLOWED.

The minimum vent diameter for the Category I venting system is as shown in the following chart:

MODEL	MINIMUM VENT	
	UPFLOW	COUNTERFLOW
045	4 Inch	4 Inch
070	4 Inch	4 Inch
090	4 Inch	4 Inch
115	5 Inch	5 Inch
140	5 Inch	5 Inch

Under some conditions, larger vents than those shown above may be required or allowed.

*When an existing furnace is removed from a venting system serving other appliances, the venting system may be too large to properly vent the remaining attached appliances. For complete details refer to *Existing Furnace Removal* section of this manual.*

When resizing any portion of the common venting system, use the appropriate table in Appendix G in the latest edition of the National Fuel Gas Code NFPA 54/ANSI Z223.1.

Upflow or Horizontal units are shipped with the induced draft blower discharging from the top of the furnace ("Top" is as viewed for an upflow installation). The induced draft blower can be rotated 90 degrees for Category I venting. Refer to the following figure. For horizontal installations, a four inch single wall pipe can be used to extend the induced draft blower outlet 1/2" beyond the furnace cabinet. Vent the furnace in accordance with the National Fuel Gas Code NFPA 54/ANSI Z223.1 - latest edition. In Canada, vent the furnace in accordance with the National Standard of Canada, CAN/CGA B149.1 and CAN/CGA B149.2 - latest editions and amendments.

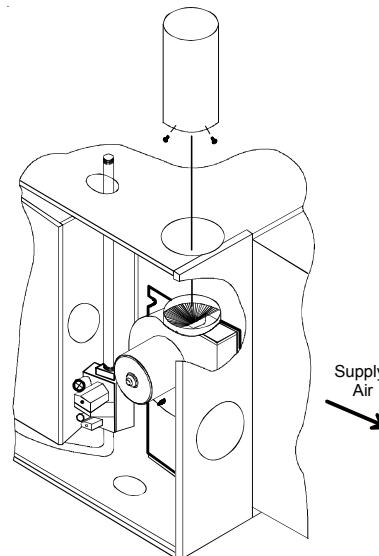

80% Upflow Rotated Induced Draft Blower

! WARNING

TO PREVENT DEATH OR SERIOUS ILLNESS TO BUILDING OCCUPANTS DUE TO FLUE PRODUCTS LEAKING INTO THE BUILDING, PROPER INSTALLATION OF GASKETS AND SCREWS IS ESSENTIAL FOR PROVIDING A GAS TIGHT SEAL BETWEEN THE PARTITION PANEL AND THE INDUCED DRAFT BLOWER.

Make sure all wires are at least one inch from flue pipe. Relocate junction box to right side of cabinet if necessary. Refer to *Electrical Connections* section of this manual for instructions.

PRODUCT DESIGN

Masonry Chimneys

WARNING

POSSIBILITY OF PROPERTY DAMAGE, PERSONAL INJURY OR DEATH - DAMAGING CONDENSATION CAN OCCUR INSIDE MASONRY CHIMNEYS WHEN A SINGLE FAN ASSISTED CATEGORY 1 APPLIANCE (80% AFUE FURNACE) IS VENTED WITHOUT ADEQUATE DILUTION AIR. DO NOT CONNECT AN 80% FURNACE TO A MASONRY CHIMNEY UNLESS THE FURNACE IS COMMON VENTED WITH THE DRAFT HOOD EQUIPPED APPLIANCE, OR THE CHIMNEY IS LINED WITH A METAL LINER OR B METAL VENT. ALL INSTALLATIONS USING MASONRY CHIMNEYS MUST BE SIZED IN ACCORDANCE WITH THE APPROPRIATE VENTING TABLES.

IF AN 80% FURNACE IS COMMON VENTED WITH THE DRAFT HOOD EQUIPPED APPLIANCE, THE POTENTIAL FOR CONDENSATION DAMAGE MAY STILL EXIST WITH EXTREMELY COLD CONDITIONS, LONG VENT CONNECTORS, EXTERIOR CHIMNEYS, OR ANY COMBINATION OF THESE CONDITIONS. THE RISK OF CONDENSATION DAMAGE IS BEST AVOIDED BY USING THE MASONRY CHIMNEY AS A PATHWAY FOR PROPERLY SIZED METAL LINER OR B METAL VENT.

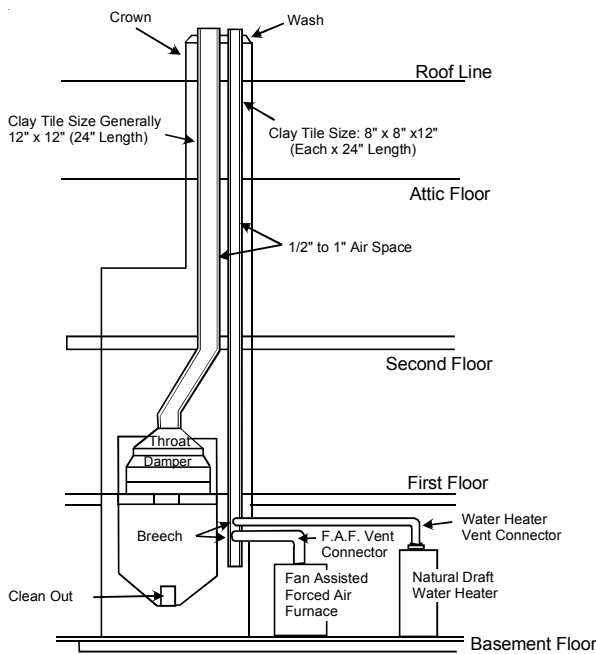

Typical Multiple Flue Clay Tile Chimney

Checklist Summary

This checklist serves as a summary of the items to be checked before venting an 80% furnace into a masonry chimney. In addition, we recommend that a qualified serviceman use this checklist to perform a yearly inspection of the furnace venting system.

This checklist is only a summary. For detailed information on each of the procedures mentioned, see the paragraph referenced with each item.

This inspection is based upon a draft topical report, "Masonry Chimney Inspection and Relining", issued by the Gas Research Institute. While not yet finalized, we believe this report represents the best information on this subject which is currently available.

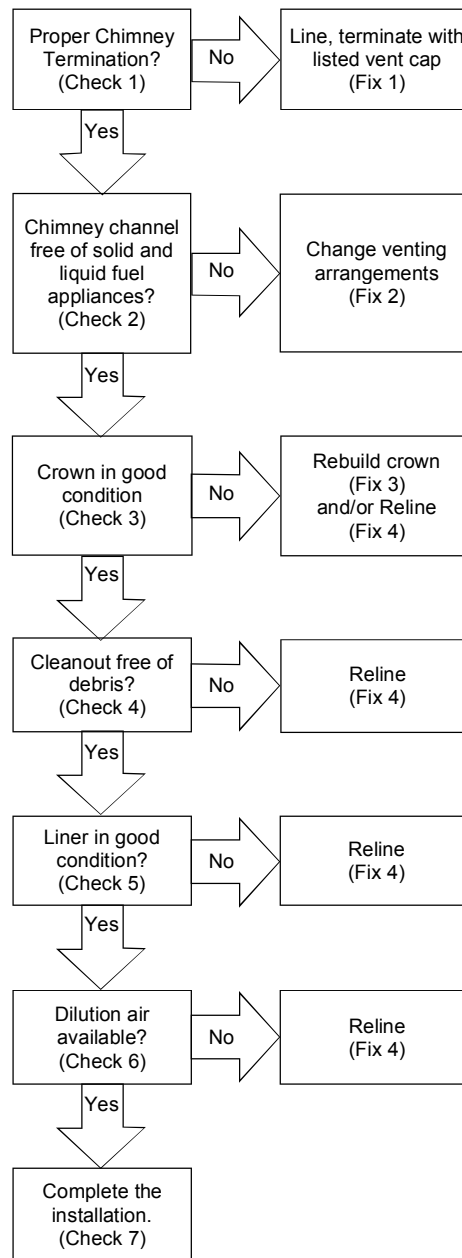

Check 1 - Proper chimney termination.

A masonry chimney used as a vent for gas fired equipment must extend at least three feet above the highest point where it passes through the roof. It must extend at least two feet higher than any portion of a building within a horizontal distance of 10 feet. In addition, the chimney must terminate at least 3 feet above any forced air inlet located within 10 feet. The chimney must extend at least five feet above the highest connected equipment draft hood outlet or flue collar.

If the chimney does not meet these termination requirements, but all other requirements in the checklist can be met, it may be possible for a mason to extend the chimney. If this will not be practical, see Fix 1.

PRODUCT DESIGN

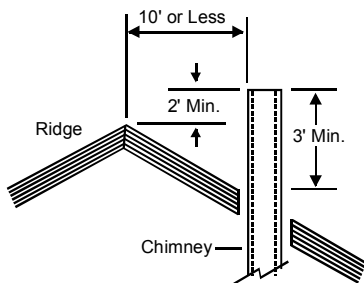
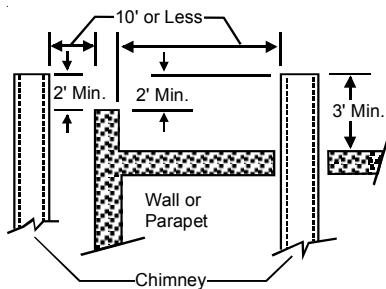

Termination 10 Feet Or Less From Ridge, Wall or Parapet

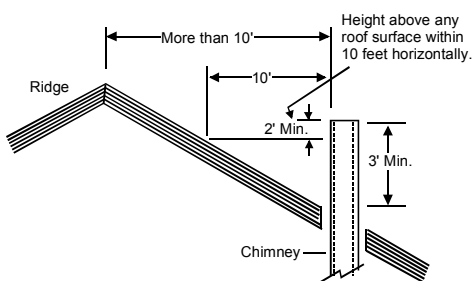
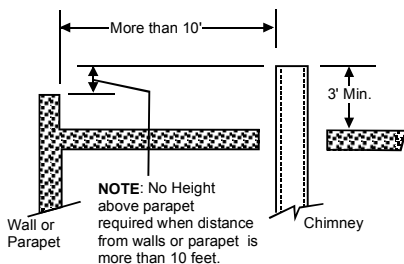

Termination More Than 10 Feet From Ridge, Wall or Parapet

Check 2 - Any solid or liquid fuel appliances vented into this chimney channel.

Solid fuel appliances include fireplaces, wood stoves, coal furnaces, and incinerators.

Liquid fuel appliances include oil furnaces, oil-fired boilers and oil-fired water heaters.

Appliances which burn propane (sometimes referred to as LP (liquefied petroleum)) gas are considered gas-fired appliances.

Check 3 - Chimney Crown Condition.

Damage from condensate usually shows up first in the crown. If any of the following trouble signs are present, the condition of the crown is not satisfactory:

- Crown leaning
- Bricks missing
- Mortar missing
- Tile liner cracked
- No tile liner
- Salt staining at mortar joints. (White stains, and mortar becomes sandy and/or erodes.)

For problems a, b, or c, see Fix 3. If problems d, e, or f are present, see Fix 4. **IMPORTANT:** It may be necessary to follow both Fix 3 and Fix 4.

Check 4 - Debris in Cleanout

A cleanout (dropleg) must be present such that the upper edge of the cleanout cover is at least 12 inches below the lower edge of the lowest chimney inlet opening.

A chimney without a cleanout could become partially blocked by debris. If no cleanout is present, the chimney must be relined (Fix 4).

Remove the cleanout cover, and examine the cleanout for debris. If significant amounts of any of the following are found:

- Fuel oil residue
- Bricks
- Mortar or sand
- Pieces of the tile liner
- Rusted pieces of the metallic liner

reline the chimney (Fix 4).

Check 5 - Liner Condition.

If a metal liner is present, it must be checked. It cannot be assumed that all existing metal liners are correctly installed and in good condition.

Remove the lowest existing vent connector, and examine the inside of the elbow or tee at the base of the liner. A small amount of soot may be considered acceptable, provided the installer vacuums it away. If rusted pieces of the liner have collected here, the metal liner must be removed and replaced (Fix 4).

Next, gently tap the inside of the liner with a Phillips screwdriver. If the screwdriver perforates the liner, or if the tapping does not sound like metal hitting metal, the liner must be removed and replaced (Fix 4).

Remember that all appliances must be vented inside the liner. Venting one appliance inside the liner and another appliance outside the liner is not acceptable.

Next, use a flashlight and small mirror to sight up the liner. B vent must be supported so as to not come into direct contact with the chimney walls or tile liner. If it is not, it can probably be rehung so as to be acceptable. A thimble or fire stop may be helpful here.

PRODUCT DESIGN

Flexible liners should be hung straight or nearly straight. If it is spiraled in the chimney and in good condition, it should be rehung. To do this, break the top seal; pull up and cut off the excess liner length, and refit the top seal. Use caution when doing this, as the cut edges of flexible liners may be sharp.

The surfaces of the liner must be physically sound. If gaps or holes are present, the metal liner must be removed and replaced (Fix 4).

Finally, confirm that the metal liner is the correct size for the appliances to be installed. Use the GAMA tables and rules. If a metal liner is not present, a clay tile liner must be present, or the chimney must be lined (Fix 4).

Use a flashlight and small mirror at the cleanout or vent connector to inspect the clay tile liner. If any of the following problems are present:

- Tile sections misaligned
- Tile sections missing
- Gaps between tile sections
- Signs of condensate drainage at the cleanout or vent connectors
- Mortar protruding from between tile sections
- Use of sewer pipe or drainage pipe rather than an approved fire clay tile

reline the chimney (Fix 4).

Next, measure the size of the liner. It may be possible to do this from the cleanout. The liner must be at least as large as the minimum size established by the tables in National Fuel Gas Code NFPA 54/ANSI Z223.1 - latest edition and in the National Standard of Canada, CAN/CGA B149.1 and CAN/CGA B149.2 - latest editions and amendments. If the liner is too small or too large, then the chimney must be relined (Fix 4).

Check 6 - Dilution Air.

If gas-fired appliances are to be vented into a clay tile liner, a source of dilution air is required.

Dilution air cannot be obtained through:

- Induced draft appliances
- Natural draft appliances with vent dampers

Sufficient dilution air can ordinarily be obtained through the draft hood of a natural draft appliance only if the appliance's vent connector does not include a vent damper.

If dilution air will not be available, the chimney must be relined (Fix 4).

Check 7 - Complete the Installation.

If Checks 1 through 6 have been satisfactory, and the liner is an acceptable size as determined by the tables in National Fuel Gas Code NFPA 54/ANSI Z223.1 - latest edition and in the National Standard of Canada, CAN/CGA B149.1 and CAN/CGA B149.2 - latest editions and amendments, then the clay tile liner can probably be used as a vent for the gas appliances. However, the installer must keep in mind the following factors which may render the tile liner unsuitable for use as a vent:

- Extremely cold weather
- Long vent connectors
- Masonry chimneys with no air gap between the liner and the bricks. (In practice, this can be difficult to detect.)
- Exterior chimneys (The tables in National Fuel Gas Code NFPA 54/ANSI Z223.1 - latest edition and in the National Standard of Canada, CAN/CGA B149.1 and CAN/CGA B149.2 - latest editions and amendments assume interior chimneys.)

If, in the judgment of the local gas utility, installer, and/or local codes; one or more of the above factors is likely to present a problem, the chimney must be relined (Fix 4).

Fix 1 - Liner Termination.

Any cap or roof assembly used with a liner must be approved by the liner manufacturer for such use. The liner and cap/roof assembly must then terminate above the roof in accordance with the manufacturer's instructions.

In some cases, a shorter extension above the roof may be possible with a liner than would be required with a masonry chimney.

For further information on relining, see Fix 4.

Fix 2 - Change Venting Arrangements

If the masonry chimney has more than one channel, it may be possible to vent the gas appliances into one channel and vent the solid or liquid fuel appliance(s) into another channel(s). Do not vent an 80% furnace inside of a metal liner with other appliances vented outside the liner.

Alternatively, the homeowner may agree to discontinue use of the fireplace (solid fuel appliance). If so, the tile liner must be cleaned to remove creosote buildup. The fireplace opening must then be permanently sealed.

If oil-fired appliance(s) are being replaced by gas-fired appliance(s), the tile liner must first be cleaned to remove the fuel oil residue.

If none of the above options are practical, the 80% furnace may need to be vented vertically with B vent.

Under some conditions a 90%+ furnace could be installed rather than an 80%. The 90% furnace can be vented horizontally or vertically through PVC pipe.

Fix 3 - Rebuild the Crown.

If the chimney crown is damaged, a qualified mason must repair it in accordance with nationally recognized building codes or standards. One such standard which may be referenced is the Standard for Chimneys, Fireplaces, Vents, and Solid Fuel Burning Appliances, ANSI/NFPA 211.

PRODUCT DESIGN

Fix 4 - Relining.

Relining options include B vent and flexible liners.

If the chimney has diagonal offsets, B vent probably cannot be used.

If B vent is to be used, it must be supported adequately. Supports (such as fire stops or thimbles) must be used to prevent the B vent from coming into direct contact with the tile liner or chimney walls. Direct contact would result in higher heat loss, with an increased possibility of poor venting system performance.

It is not acceptable to vent one appliance inside the B vent and other appliances outside. The excess space between the B vent and the chimney walls must be covered at the top of the chimney by a weatherproof, corrosion resistant flashing.

The B vent should then be topped with a listed vent cap. The listed vent cap will, when installed per the manufacturer's instructions, prevent problems due to rain, birds, or wind effects.

A B vent installed as described in this section is considered to be an enclosed vent system, and the sizing tables in National Fuel Gas Code NFPA 54/ANSI Z223.1 - latest edition and in the National Standard of Canada, CAN/CGA B149.1 and CAN/CGA B149.2 - latest editions and amendments may be used.

If a flexible liner is to be used, it must be made of the proper materials:

- For most residential applications, an aluminum liner should be acceptable.
- If the combustion air supplied to the furnace will be contaminated with compounds containing chlorine or fluorine, a liner of AL29-4C stainless steel should be used. Common sources of chlorine and fluorine compounds include indoor swimming pools and chlorine bleaches, paint strippers, adhesives, paints, varnishes, sealers, waxes (which are not yet dried) and solvents used during construction and remodeling. Various commercial and industrial processes may also be sources of chlorine/fluorine compounds.
- Heavier gauge 300 and 400 series stainless steel liners were developed for use with oil or solid fuel appliances. They are not suitable for use with gas-fired appliances. Flexible liners specifically intended and tested for gas applications are listed in the UL "Gas and Oil Equipment Directory". (UL Standard 1777).

For sizing of flexible liners, see Note 22 and the tables in the National Fuel Gas Code NFPA 54/ANSI Z223.1 - latest edition and in the National Standard of Canada, CAN/CGA B149.1 and CAN/CGA B149.2 - latest editions and amendments.

To install the liner, read and follow the liner manufacturer's instructions and your local codes. Excess liner length should be pulled out of the chimney and cut off. Use caution when doing this, as the cut edges of flexible liners may be sharp.

Do not spiral excess liner inside of the chimney. Support the liner as recommended by the liner manufacturer.

Some manufacturers of flexible liners offer an insulation sleeve designed to be added to the liner before it is installed in the chimney. (Poured insulation, either vermiculite or other materials, is no longer recommended.) Insulation will need to be added to the flexible liner if:

- It is required by the liner manufacturer's instructions.
- The previous liner was properly sized and installed, and suffered from condensation damage.
- It is required by your local building codes.

Even if none of those three conditions exist which require additional liner insulation, the installer may wish to consider it if:

- The local climate is very cold.
- The chimney is very tall.
- The vent connectors used are very long or have a large number of elbows.
- Local experience indicates that flexible liners installed without insulation are likely to have condensation problems.

Insulation must be selected and installed in accordance with the liner manufacturer's instructions.

Finally, cap the chimney and terminate the liner in accordance with the liner manufacturer's instructions.

Horizontal Applications and Considerations

Horizontal applications, in particular, may dictate many of the installation's specifics such as airflow direction, ductwork connections, flue and/or combustion air pipe connections, etc. The basic application of this furnace as a horizontal furnace differs only slightly from an upright installation. When installing a furnace horizontally, additional consideration must be given to the following:

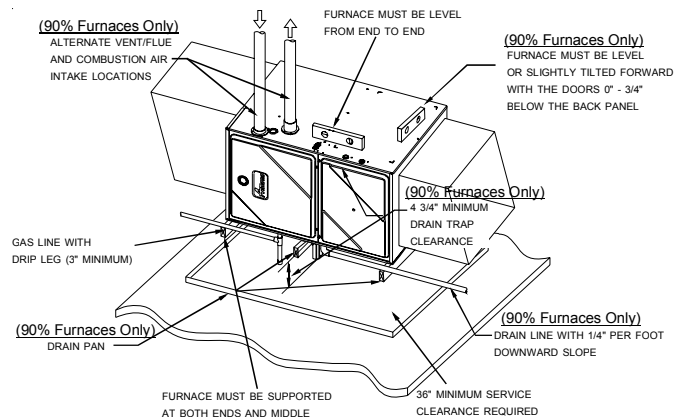

**90% Horizontal Furnace Shown
(80% Horizontal Furnace Similar)**

PRODUCT DESIGN

Drain Trap and Lines (90% Furnaces Only)

In horizontal applications the condensate drain trap is secured to the furnace side panel, suspending it below the furnace. A minimum clearance of 4 3/4" below the furnace must be provided for the drain trap. Additionally, the appropriate downward piping slope must be maintained from the drain trap to the drain location. Refer to *Condensate Drain Trap and Lines* section in this manual or the installation instructions for further details. If the drain trap and drain line will be exposed to temperatures near or below freezing, adequate measures must be taken to prevent condensate from freezing. **NOTE:** The use of insulation and/or heat tape is recommended. Failure to provide proper condensate drainage can result in property damage.

Leveling (90% Furnaces Only)

Leveling ensures proper condensate drainage from the heat exchanger and induced draft blower. For proper flue pipe drainage, the furnace must be level lengthwise from end to end. The furnace should also be level from back to front or have a slight tilt with the access doors downhill (approximately 3/4") from the back panel. The slight tilt allows the heat exchanger condensate, generated in the recuperator coil, to flow forward to the recuperator coil front cover.

Alternate Vent/Flue and Combustion Air Connections (90% Furnaces Only)

NOTE: Alternate combustion fresh air inlet location on the right hand panel side of 90% furnace models has been discontinued since November 2005.

In horizontal installations provisions for alternate flue and combustion air piping are available for upflow furnaces with left discharge. In these positions the flue and combustion air piping can be run vertically through the side of the furnace. Refer to the following figure "Recommended Installation Positions" for further detail. The standard piping connections may also be used in these positions. Refer to *Vent/Flue Pipe and Combustion Air Pipe* section in this manual or the installation instructions for details concerning the conversion to the alternate vent/flue and combustion air connections on the 90% furnace.

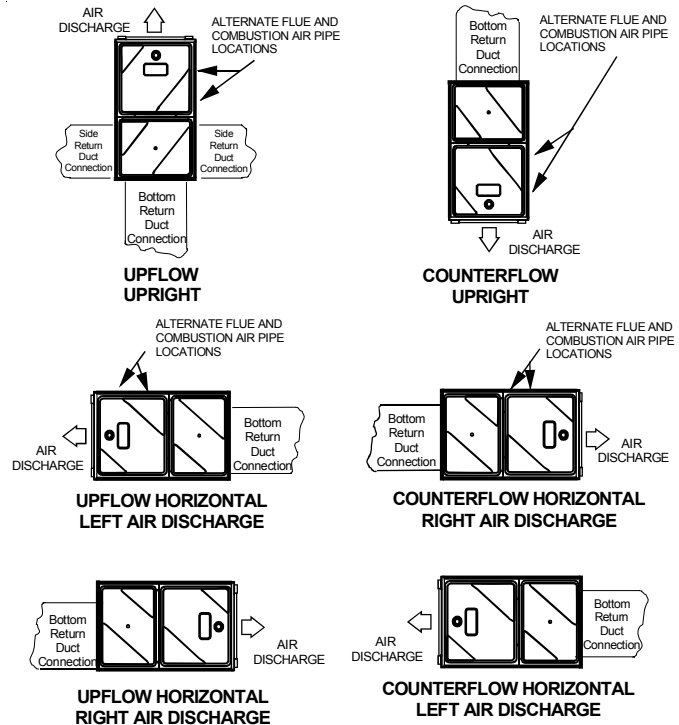

90% Furnace Recommended Installation Positions

NOTE: Alternate "vertical" piping connections can not be used when an upflow 90% furnace is installed with supply air discharging to the right or when a counterflow furnace is installed with supply discharging to the left. In this case, use the standard flue and combustion air piping connections

Alternate Electrical and Gas Line Connections

The 80% & 90% furnaces have provisions allowing for electrical and gas line connections through either side panel. In horizontal applications the connections can be made either through the "top" or "bottom" of the furnace.

Drain Pan (90% Furnaces Only)

A drain pan must be provided if the furnace is installed above a conditioned area. The drain pan must cover the entire area under the furnace (and air conditioning coil if applicable).

Freeze Protection (90% Furnaces Only)

If the drain trap and drain line will be exposed to temperatures near or below freezing, adequate measures must be taken to prevent condensate from freezing. **NOTE:** The use of insulation and/or heat tape is recommended. Failure to provide proper condensate drainage can result in property damage.

PRODUCT DESIGN

Propane Gas and/or High Altitude Installations



WARNING

POSSIBLE PROPERTY DAMAGE, PERSONAL INJURY OR DEATH MAY OCCUR IF THE CORRECT CONVERSION KITS ARE NOT INSTALLED. THE APPROPRIATE KITS MUST BE APPLIED TO INSURE SAFE AND PROPER FURNACE OPERATION. ALL CONVERSIONS MUST BE PERFORMED BY A QUALIFIED INSTALLER OR SERVICE AGENCY.

This furnace is shipped from the factory configured for natural gas at standard altitude. Propane gas installations require an orifice change to compensate for the energy content difference between natural and propane gas.

High altitude installations may require both a pressure switch and an orifice change. These changes are necessary to compensate for the natural reduction in the density of both the gas fuel and the combustion air at high altitude.

Refer to the *Accessories Charts* in this manual or product Specification Sheet for a tabular listing of appropriate manufacturer's kits for propane gas and/or high altitude installations. The indicated kits must be used to insure safe and proper furnace operation. All conversions must be performed by a qualified installer, or service agency.

VENT/FLUE PIPE AND COMBUSTION AIR PIPE (90% FURNACES ONLY)



WARNING

FAILURE TO FOLLOW THESE INSTRUCTIONS CAN RESULT IN BODILY INJURY OR DEATH. CAREFULLY READ AND FOLLOW ALL INSTRUCTIONS GIVEN IN THIS SECTION.



WARNING

UPON COMPLETION OF THE FURNACE INSTALLATION, CAREFULLY INSPECT THE ENTIRE FLUE SYSTEM BOTH INSIDE AND OUTSIDE THE FURNACE TO ASSURE IT IS PROPERLY SEALED. LEAKS IN THE FLUE SYSTEM CAN RESULT IN SERIOUS PERSONAL INJURY OR DEATH DUE TO EXPOSURE TO FLUE PRODUCTS, INCLUDING CARBON MONOXIDE.

A condensing gas furnace achieves its high level of efficiency by extracting almost all of the heat from the products of combustion and cooling them to the point where condensation takes place. Because of the relatively low flue gas temperature and water condensation requirements, PVC pipe is used as venting material.

This furnace must not be connected to Type B, BW, or L vent or vent connector, and must not be vented into any portion of a factory built or masonry chimney except when used as a pathway for PVC as described later in this section. **Never** common vent this appliance with another appliance or use a vent which is used by a solid fuel appliance.

Do not use commercially available "no hub connectors" other than those shipped with this product.

It is the responsibility of the installer to follow the manufacturers' recommendations and to verify that all vent/flue piping and connectors are compatible with furnace flue products. Additionally, it is the responsibility of the installer to ensure that all piping and connections possess adequate structural integrity and support to prevent flue pipe separation, shifting, or sagging during furnace operation.

Dual Certification: Non-Direct/Direct Vent (90% Furnaces Only)

The 90% furnace is dual certified and may be installed as a non-direct vent (single pipe) or direct vent (dual pipe) appliance. A **non-direct vent** installation requires only a vent/flue pipe. A **direct vent** installation requires both a vent/flue pipe and a combustion air intake pipe. Refer to the appropriate section for details concerning piping size, length, number of elbows, furnace connections, and terminations.

Concentric Vent Termination (90% Furnaces Only)

The Concentric Vent Kits DCVK-20 and DCVK-30 are designed to allow the terminations of a direct vent furnace to be "concentrically" vented through a wall or roof. These kits allow a single penetration to support terminations for both the vent/flue pipe and the combustion air intake pipe.

The Sidewall Vent Kit # 0170K0000S is used with 2" or 3" dual pipe installations. This kit is NOT intended for use with single pipe (non-direct vent) installations. You **MUST** connect the kit as a (direct vent) two-pipe installation.

NOTE: This kit is not certified for, and must not be applied to any furnace not listed in this service manual.

Refer to the directions provided with the concentric vent kit for installation specifications.

NOTE: The previously used concentric vent kits, HCVK (designed for horizontal, through the wall terminations) and the VCVK were approved for use in Service Bulletins GF-172 and S-199 (designed for vertical, through the roof terminations.) The appropriate kit must be used for a given termination placement (horizontal or vertical).

Materials and Joining Methods (90% Furnaces Only)



WARNING

TO AVOID BODILY INJURY, FIRE OR EXPLOSION, SOLVENT CEMENTS MUST BE KEPT AWAY FROM ALL IGNITION SOURCES (I.E., SPARKS, OPEN FLAMES, AND EXCESSIVE HEAT) AS THEY ARE COMBUSTIBLE LIQUIDS. AVOID BREATHING CEMENT VAPORS OR CONTACT WITH SKIN AND/OR EYES.

Two or three inch nominal diameter PVC Schedule 40 pipe meeting ASTM D1785, PVC primer meeting ASTM F656, and PVC solvent cement meeting ASTM D2564 specifications must be used. Fittings must be DWV type fittings meeting ASTM D2665 and ASTM D3311. Carefully follow the manufacturer's instructions for cutting, cleaning, and solvent cementing of PVC.

PRODUCT DESIGN

As an alternative to PVC pipe, primer, solvent cement, and fittings, ABS materials which are in compliance with the following specifications may be used. Two or three inch ABS Schedule 40 pipe must meet ASTM D1527 and, if used in Canada, must be CSA listed. Solvent cement for ABS to ABS joints must meet ASTM D2235 and, if used in Canada, must be CSA listed. The solvent cement for the PVC to ABS transition joint must meet ASTM D3138. Fittings must be DWV type fittings meeting ASTM D2661 and ASTM D3311 and, if used in Canada, must be CSA listed. Carefully follow the manufacturers' instructions for cutting, cleaning, and solvent cementing PVC and/or ABS.

All 90° elbows must be medium radius (1/4 bend DWV) or long radius (Long sweep 1/4 bend DWV) types conforming to ASTM D3311. A medium radius (1/4 bend DWV) elbow measures 3 1/16" minimum from the plane of one opening to the centerline of the other opening for 2" diameter pipe, and 4 9/16" minimum for 3" pipe.

Proper Vent/Flue and Combustion Air Piping Practices (90% Furnaces Only)

Adhere to these instructions to ensure safe and proper furnace performance. The length, diameter, and number of elbows of the vent/flue pipe and combustion air pipe (when applicable) affects the performance of the furnace and must be carefully sized. All piping must be installed in accordance with local codes and these instructions.

Piping must be adequately secured and supported to prohibit sagging, joint separation, and/or detachment from the furnace. Horizontal runs of vent/flue piping must be supported every three feet and must maintain a 1/4 inch per foot downward slope, back towards the furnace, to properly return condensate to the furnace's drain system. Allowances should be made for minor expansion and contraction due to temperature variations. For this reason, particular care must be taken to secure piping when a long run is followed by a short offset of less than 40 inches.

Precautions should be taken to prevent condensate from freezing inside the vent/flue pipe and/or at the vent/flue pipe termination. All vent/flue piping exposed to freezing temperatures below 35° F for extended periods of time must be insulated with 1/2" thick closed cell foam. Also all vent/flue piping exposed outdoors in excess of the terminations shown in this manual (or in unheated areas) must be insulated with 1/2" thick closed cell foam such as "Armaflex" or "Insultube". Inspect piping for leaks prior to installing insulation.

Termination Locations (90% Furnaces Only)

NOTES: Refer to *Location Requirements and Considerations* section of this manual or the installation instructions for combustion air contaminant restrictions.

The following bullets and diagram describe the restrictions concerning the appropriate location of vent/flue pipe and combustion air intake pipe (when applicable) terminations. Refer to *Non-Direct Vent (Single Pipe) Piping* and *Direct Vent (Dual Pipe) Piping* sections located in this manual or the installation instructions for specific details on termination construction.

- All terminations must be located at least 12 inches above ground level or the anticipated snow level.
- Vent terminations must terminate at least 3 feet above any forced air inlet located within 10 feet.
- **NOTE:** This provision does not apply to the combustion air intake termination of a direct vent application.
- The vent termination of a *non-direct vent* application must terminate at least 4 feet below, 4 feet horizontally from, or 1 foot above any door, window, or gravity air inlet into any building.
- The vent termination of a *direct vent* application must terminate at least 12 inches from any opening through which flue gases may enter a building (door, window, or gravity air inlet).
- The vent termination of vent pipe run vertically through a roof must terminate at least 12 inches above the roof line (or the anticipated snow level) and be at least 12 inches from any vertical wall (including any anticipated snow build up).
- A vent termination shall not terminate over public walkways or over an area where condensate or vapor could create a nuisance or hazard or could be detrimental to the operation of regulators, relief valves, or other equipment.
- The combustion air intake termination of a direct vent application should not terminate in an area which is frequently dusty or dirty.

NOTE: In Canada, the Canadian Fuel Gas Code takes precedence over the preceding termination restrictions.

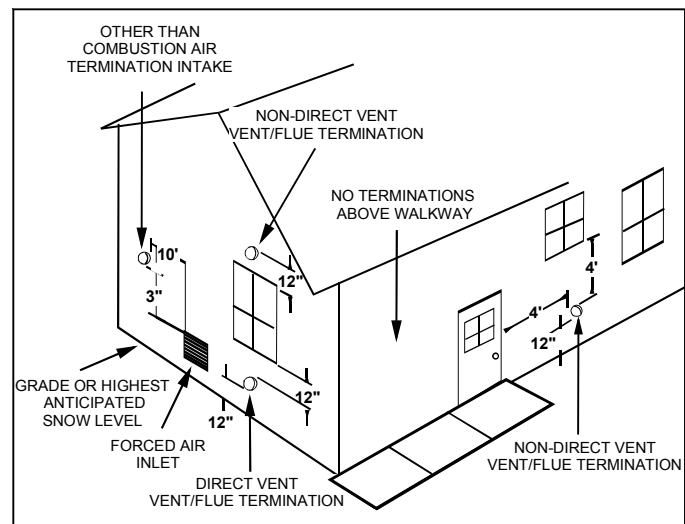

90% Furnace Vent Termination Clearances

PRODUCT DESIGN

Canadian Venting Requirements (90% Furnaces Only)

In Canada, venting must conform to the requirements of the current CAN/CGA-B149 Installation Code. Use only CSA listed two or three inch diameter PVC or ABS pipe, solvent cement, and fittings throughout. Carefully follow the manufacturers' instructions for cutting, cleaning, and solvent cementing PVC and/or ABS.

The vent can be run through an existing unused chimney provided the space between the vent pipe and the chimney is insulated and closed with a weather-tight, corrosion-resistant flashing.

The vent shall *not* be located:

- Less than 12 inches above the finished grade line.
- Less than 36 inches from any building opening or any gas service regulator. For gas service regulators in the Province of Ontario, 72 inches.
- Less than 72 inches from the combustion air intake of another appliance.
- Directly above a gas utility meter or service regulator.
- Over a walkway unless located 84 inches above grade.

Standard Furnace Connections (90% Furnaces Only)

It is the responsibility of the installer to ensure that the piping connections to the furnace are secure, airtight, and adequately supported.

As shipped, attachment "couplings" for vent/flue and combustion air intake pipe connections are provided on the furnace's top cover (upflow). To use the standard connections, field supplied vent/flue pipe and combustion air intake pipe (when applicable) should be secured directly to the furnace at these locations.

Vent/Flue Pipe (90% Furnaces Only)

Vent/flue pipe can be secured to the vent/flue coupling using the rubber coupling and worm gear hose clamps provided with this furnace. Torque hose clamps to 20 inch-lbs (see "Standard Connections" figure). The rubber coupling allows separation of the vent/flue pipe from the furnace during servicing. **NOTE:** Do not use other commercially available "no hub connectors" due to possible material conflicts. The vent/flue pipe can also be secured using a PVC or ABS elbow or coupling using the appropriate glue (see *Materials and Joining Methods* section in this manual or the installation instructions for further details).

NOTE: For *non-direct vent* installations, a minimum of one 90° elbow must be installed on the combustion air intake coupling to guard against inadvertent blockage.

Combustion Air Pipe (90% Furnaces Only)

Direct Vent Installations

On *upflow* units secure the combustion air intake pipe directly to the air intake coupling. On *counterflow* units secure the combustion air intake pipe to the air intake coupling using the rubber coupling and worm gear hose clamps

provided with the unit. The counterflow rubber coupling allows service removal of air intake piping internal to the furnace blower compartment. **NOTE:** Because of probable material conflicts, do not use other commercially available "no hub connectors". The combustion air intake pipe can also be secured directly to the counterflow unit air intake pipe coupling.

Non-Direct Vent Installations

A minimum of one 90° elbow must be installed on the combustion air intake "coupling" to guard against inadvertent blockage.

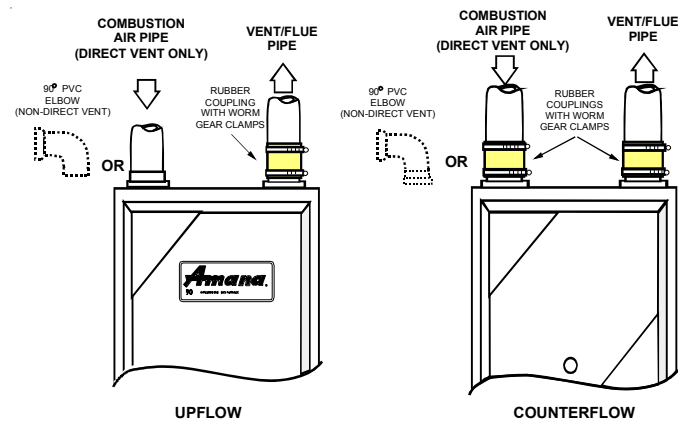

90% Furnace Vent/Flue & Combustion Air Standard Connections

Alternate Furnace Connections (90% Furnaces Only)

NOTE: Alternate combustion fresh air inlet location on the right hand panel side of 90% furnace models was discontinued since November 2005).

If the standard locations are undesirable for a specific installation, alternate side panel locations are available for both alternate combustion air inlet and vent/flue pipe connections. These locations may be of particular benefit to upright upflow installations requiring additional access to an A coil or to horizontal installations desiring vent/flue (and combustion air intake) piping run vertically from the side of the cabinet.

NOTE: Standard and alternate locations can be combined (i.e., an installation may use the standard combustion air intake location but use the alternate vent/flue location or vice versa), if needed.

 **CAUTION**

EDGES OF SHEET METAL HOLES MAY BE SHARP. USE GLOVES A PRECAUTION WHEN REMOVING HOLE PLUGS.

The alternate vent/flue location is the large hole directly in line with the induced draft blower outlet. Refer to the following "Alternate Vent/Flue Location" figure for details.

PRODUCT DESIGN

⚠ WARNING

THE RUBBER ELBOW IS NOT DESIGNED TO SUPPORT A LOAD. WHEN THE RUBBER ELBOW IS MOUNTED EXTERNALLY TO THE FURNACE CABINET, EXTREME CARE MUST BE TAKEN TO ADEQUATELY SUPPORT FIELD-SUPPLIED VENT/FLUE PIPING, AS DAMAGE CAN RESULT IN LEAKS CAUSING BODILY INJURY OR DEATH DUE TO EXPOSURE TO FLUE GASES, INCLUDING CARBON MONOXIDE.

For **upright installations**, externally mount the rubber elbow to the vent/flue coupling using a worm gear hose clamp. Secure field supplied vent/flue piping to the rubber elbow using a worm gear hose clamp. **NOTE:** Use of the alternate vent/flue location for upright installations, requires the drain trap be installed on the same side of the unit as the flue pipe.

For **horizontal installations**, externally secure the field-supplied vent/flue pipe directly to the vent/flue coupling using a PVC or ABS coupling or elbow.

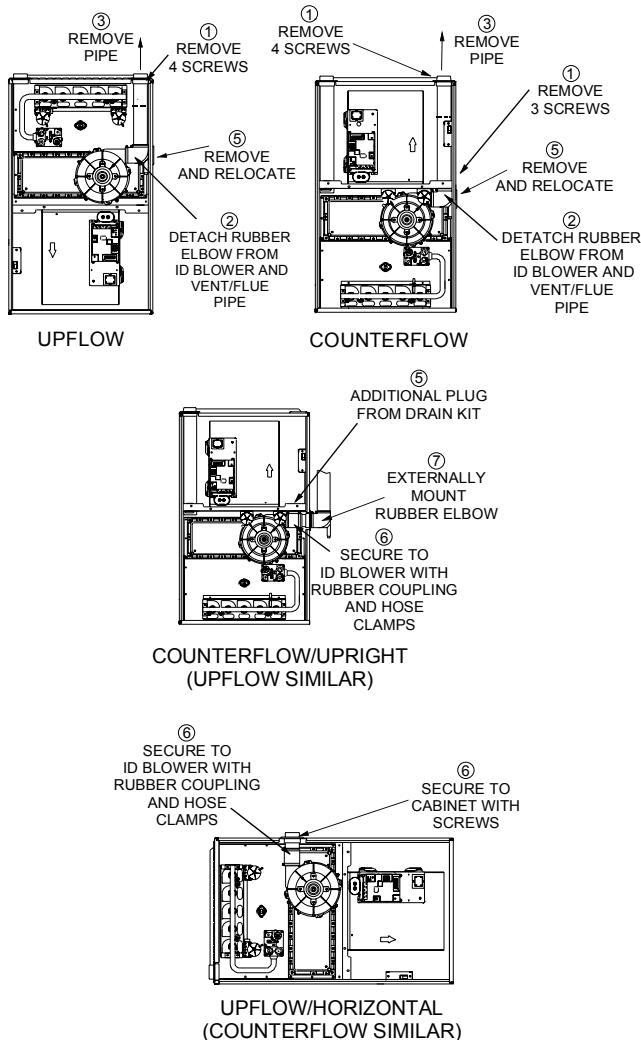

90% Furnace Alternate Vent/Flue Location

Alternate Combustion Air Intake Location (90% Furnaces Only)

NOTE: Alternate combustion fresh air inlet location on the right hand panel side of 90% furnace models was discontinued since November 2005).

The alternate combustion air intake location is the large hole *not* in line with the induced draft blower outlet. Refer to the following "Alternate Combustion Air Intake Location" figure for details.

⚠ CAUTION

BE SURE NOT TO DAMAGE INTERNAL WIRING OR OTHER COMPONENTS WHEN REINSTALLING COUPLING AND SCREWS.

For **non-direct vent installations** installed *horizontally*, a minimum of one 90° elbow must be installed on the combustion air intake coupling to guard against inadvertent blockage. No elbow is required on the alternate combustion air intake of *upright* installations, however, a minimum clearance of 2 inches is required to assure proper air supply.

For **direct vent installations**, secure field-supplied combustion air intake pipe directly to the air intake coupling.

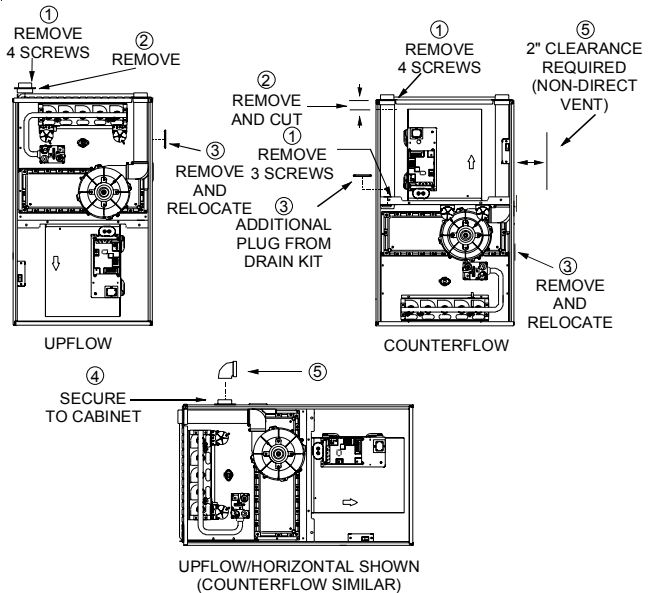

90% Furnace Alternate Combustion Air Intake Location

Non-Direct Vent (Single Pipe) Piping (90% Furnaces Only)

Non-direct vent installations require only a vent/flue pipe. The vent pipe can be run horizontally with an exit through the side of the building or run vertically with an exit through the roof of the building. The vent can also be run through an existing *unused* chimney; however, it must extend a minimum of 12 inches above the top of the chimney. The space

PRODUCT DESIGN

between the vent pipe and the chimney must be closed with a weather-tight, corrosion-resistant flashing. For details concerning connection of the vent/flue pipe to the furnace, refer to *Vent/Flue Pipe and Combustion Air Pipe - Standard Furnace Connections or Alternate Furnace Connections* section in this manual or the installation instructions for specific details. Refer to the following *Non-Direct Vent (Single Pipe) Piping - Vent/Flue Pipe Terminations* section in this manual or the installation instructions for specific details on termination construction.

Although *non-direct vent* installations do not require a combustion air intake pipe, a minimum of one 90° elbow must be attached to the furnace's combustion air intake *if*, an upright installation uses the standard intake location, or a horizontal installation uses the alternate air intake location. This elbow will guard against inadvertent blockage of the air intake.

NOTE: Alternate combustion fresh air inlet location on the right hand panel side of 90% furnace models was discontinued since November 2005).

Vent/Flue Pipe Lengths (Non-Direct Vent) and Diameters (90% Furnaces Only)

Refer to the following tables for applicable length, elbows, and pipe diameter for construction of the vent/flue pipe system of a non-direct vent installation. In addition to the vent/flue pipe, a single 90° elbow must be secured to the combustion air intake to prevent inadvertent blockage. The tee or elbows used in the vent/flue termination must be included when determining the number of elbows in the piping system.

AMS9, ACS9, DMS9, DCS9, GMS9, GCH9, GCS9

Non-Direct Vent (Single Pipe)								
Maximum Allowable Length of Vent/Flue Pipe (ft) ⁽¹⁾ ⁽²⁾								
Unit Input (BTU)	Pipe Size ⁽⁴⁾ (inc.)	Number of Elbows ⁽³⁾ ⁽⁵⁾						
		2	3	4	5	6	7	8
45,000	2	68	65	62	59	56	53	50
70,000	2	68	65	62	59	56	53	50
90,000	2	60	57	55	52	50	47	45
115,000	2	25	22	20	17	15	12	10
	3	58	55	52	49	46	43	40

- 1) One 90° elbow should be secured to the combustion air intake connection.
- 2) Minimum requirement for each vent pipe is five (5) feet in length and one elbow/tee.
- 3) Tee used in the vent/flue termination must be included when determining the number of elbows in the piping system.
- 4) 3" diameter pipe can be used in place of 2" diameter pipe.
- 5) Increased Clearance Configurations using (2) 45 deg. Long Sweep elbows should be considered equivalent to one 90 deg. elbow.

GKS9

Non-Direct Vent (Single Pipe)								
Maximum Allowable Length of Vent/Flue Pipe (ft) ⁽¹⁾ ⁽²⁾								
Models (kBTU_Tons)	Pipe Size ⁽⁴⁾ (in.)	Number of Elbows ⁽³⁾ ⁽⁵⁾						
		2	3	4	5	6	7	8
045_3	2	68	65	62	59	56	53	50
070_3	2	36	33	30	27	24	21	18
	3	68	65	62	59	56	53	50
070_4	2	55	52	49	46	43	40	37
090_4	2	37	34	31	28	25	22	19
	3	68	65	62	59	56	53	50
090_5	2	39	36	33	30	27	24	21
	3	68	65	62	59	56	53	50
115_5	3	68	65	62	59	56	53	50

AMH95, GMH95, AMS95, GMS95

Non-Direct Vent (Single Pipe)								
Maximum Allowable Length of Vent/Flue Pipe (ft) ⁽¹⁾ ⁽²⁾								
Models (kBTU_Tons)	Pipe Size ⁽⁴⁾ (inc.)	Number of Elbows ⁽³⁾ ⁽⁵⁾						
		2	3	4	5	6	7	8
045_3	2	68	65	62	59	56	53	50
070_3	2	68	65	62	59	56	53	50
070_4	2	46	43	40	Not Recommended			
090_4	2	16	13	10				
	3	68	65	62	59	56	53	50
090_5	3	68	65	62	59	56	53	50
115_5	3	68	65	62	59	56	53	50

- 1) One 90° elbow should be secured to the combustion air intake connection.
- 2) Minimum requirement for each vent pipe is five (5) feet in length and one elbow/tee.
- 3) Tees and/or elbows used in the vent/flue termination must be included when determining the number of elbows in the piping system.
- 4) 3" diameter pipe can be used in place of 2" diameter pipe.
- 5) Increased Clearance Configurations using (2) 45 deg. Long Sweep elbows should be considered equivalent to one 90 deg. elbow.

Vent/Flue and Combustion Air Pipe Lengths and Diameters (95% Furnaces Only)

Refer to the following table for applicable length, elbows, and pipe diameter for construction of the vent/flue and combustion air intake pipe systems of a non-direct vent (single pipe) installation. The number of elbows tabulated represents the number of elbows and/or tees in each (Vent/Flue & Combustion Air Intake) pipe. Elbows and/or tees used in the terminations must be included when determining the number of elbows in the piping systems.

If the combustion air intake pipe is to be installed above a finished ceiling or other area where dripping of condensate will be objectionable, insulation of the combustion air pipe may be required. Use 1/2" thick closed cell foam insulation such as Armaflex or Insultube where required.

PRODUCT DESIGN

ACV9, AMV9, GCV9, GMV9, GMV95

UPFLOW									
Non-Direct Vent (Single Pipe)									
Maximum Allowable Length of Vent/Flue Pipe (ft) ⁽¹⁾⁽²⁾									
Unit Input	Pipe ⁽⁴⁾ (inch)	Number of Elbows ⁽³⁾⁽⁵⁾							
		1	2	3	4	5	6	7	8
45,000	2	71	68	65	62	59	56	53	50
70,000	2	49	46	43	40	37	34	31	28
	3	71	68	65	62	59	56	53	50
90,000	3	71	68	65	62	59	56	53	50
115,000	3	49	46	43	40	37	34	31	28

COUNTERFLOW									
Non-Direct Vent (Single Pipe)									
Maximum Allowable Length of Vent/Flue Pipe (ft) ⁽¹⁾⁽²⁾									
Unit Input	Pipe ⁽⁴⁾ (inch)	Number of Elbows ⁽³⁾⁽⁵⁾							
		1	2	3	4	5	6	7	8
70,000	2	61	58	55	52	49	46	43	40
	3	71	68	65	62	59	56	53	50
90,000	2	61	58	55	52	49	46	43	40
	3	71	68	65	62	59	56	53	50

- 1) One 90° elbow should be secured to the combustion air intake connection.
- 2) Minimum requirement for each vent pipe is five (5) feet in length and one elbow/tee.
- 3) Tee used in the vent/flue termination must be included when determining the number of elbows in the piping system.
- 4) 3" diameter pipe can be used in place of 2" diameter pipe.
- 5) Increased Clearance Configurations using (2) 45 deg. Long Sweep elbows should be considered equivalent to one 90 deg. elbow.

Vent/Flue Pipe Terminations (90% Furnaces Only)

The vent/flue pipe may terminate vertically, as through a roof, or horizontally, as through an outside wall.

Vertical vent/flue pipe termination should be as shown in the following figures. Refer to *Vent/Flue Pipe and Combustion Air Pipe - Termination Locations* section in this manual or the installation instructions for details concerning location restrictions. The penetration of the vent through the roof must be sealed tight with proper flashing such as is used with a plastic plumbing vent.

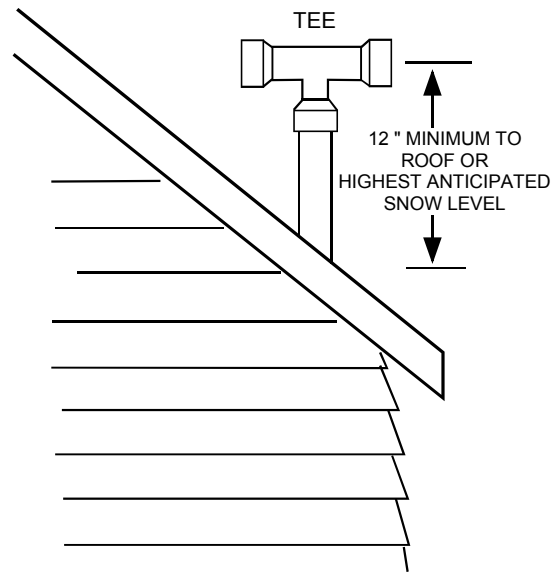

90% Furnace Standard Vertical Termination (Single Pipe)

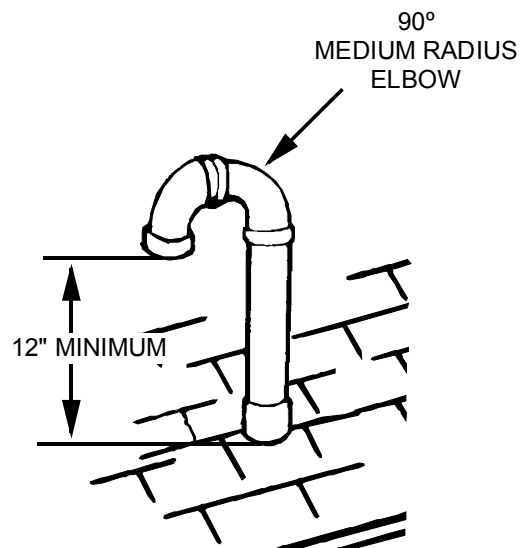

90% Furnace Alternate Vertical Termination (Single Pipe)

Horizontal vent/flue pipe terminations should be as shown in the following figure. Refer to *Vent/Flue Pipe and Combustion Air Pipe - Termination Locations* section in this manual or the installation instructions for details concerning location restrictions. A 2 3/8" diameter wall penetration is required for 2" diameter pipe while a 3 1/2" diameter hole is required for 3" diameter pipe. To secure the pipe passing through the wall and prohibit damage to piping connections, a coupling should be installed on either side of the wall and solvent cemented to a length of pipe connecting the two couplings. The length of pipe should be the wall thickness plus the depth of the socket fittings to be installed on the inside and outside of the wall. The wall penetration should be sealed with silicone caulking material.

PRODUCT DESIGN

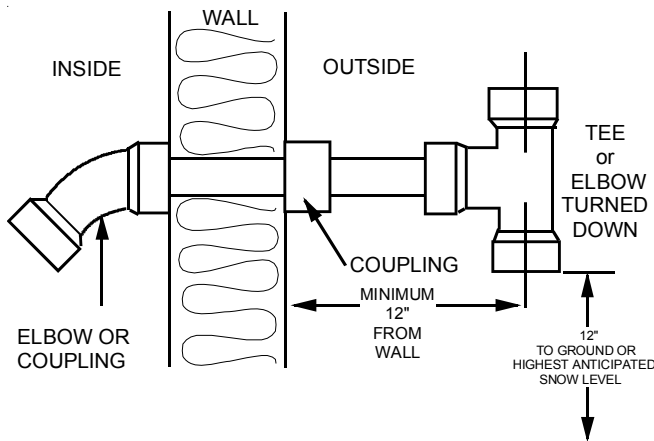

90% Furnace Horizontal Termination (Single Pipe)

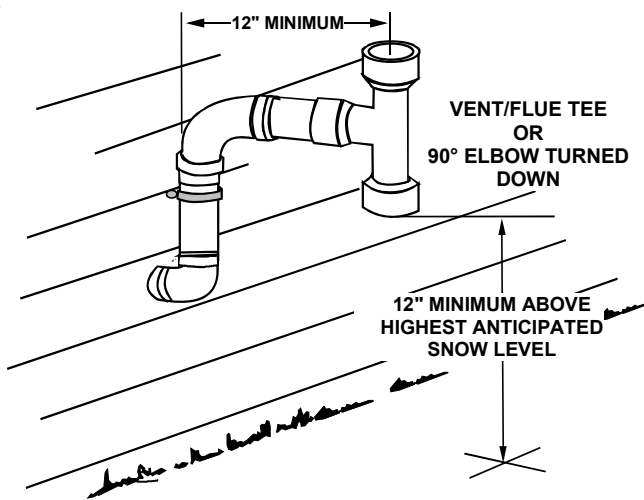

90% Furnace Horizontal Termination (Single Pipe) Above Highest Anticipated Snow Level

In a basement installation, the vent/flue pipe can be run between joist spaces. If the vent pipe must go below a joist and then up into the last joist space to penetrate the header, two 45° elbows should be used to reach the header rather than two 90° elbows.

Direct Vent (Dual Pipe) Piping (90% Furnaces Only)

Direct vent installations require both a combustion air intake and a vent/flue pipe. The pipes may be run horizontally and exit through the side of the building or run vertically and exit through the roof of the building. The pipes may be run through an existing *unused* chimney; however, they must extend a minimum of 12 inches above the top of the chimney. The space between the pipes and the chimney must be closed with a weather tight, corrosion resistant flashing. Both the combustion air intake and a vent/flue pipe terminations must be in the same atmospheric pressure zone. Refer to *Vent/Flue and Combustion Air Pipe - Termination Locations or Concentric Vent Termination* section in this manual

or the installation instructions for specific details on termination construction.

For details concerning connection of pipes to the furnace, refer to the *Vent/Flue Pipe and Combustion Pipe - Standard Furnace Connections or Alternate Furnace Connections* section in this manual or the installation instructions.

Vent/Flue and Combustion Air Pipe Lengths (Direct Vent) and Diameters (90% Furnaces Only)

Refer to the following tables for applicable length, elbows, and pipe diameter for construction of the vent/flue and combustion air intake pipe systems of a direct vent (dual pipe) installation. The number of elbows tabulated represents the number of elbows and/or tees in each (Vent/Flue & Combustion Air Intake) pipe. Elbows and/or tees used in the terminations must be included when determining the number of elbows in the piping systems.

If the combustion air intake pipe is to be installed above a finished ceiling or other area where dripping of condensate will be objectionable, insulation of the combustion air pipe may be required. Use 1/2" thick closed cell foam insulation such as "Armaflex" or "Insultube" where required.

AMS9, ACS9, DMS9, DCS9, GCH9, GMS9, GCS9

Direct Vent (Dual Pipe)									
Maximum Allowable Length of Vent/Flue & Combustion Air Intake Pipe (ft)									
Unit Input (Btu)	Vent/Flue/Air Intake Termination	Pipe Size ⁽⁴⁾ (in.)	Number of Elbows ⁽¹⁾⁽²⁾⁽³⁾⁽⁵⁾						
			2	3	4	5	6	7	8
45,000	Standard	2	68	65	62	59	56	53	50
	Alternate	2	55	52	49	46	43	40	37
70,000	Standard	2	68	65	62	59	56	53	50
	Alternate	2	55	52	49	46	43	40	37
90,000	Standard	2	55	52	49	46	43	40	37
	Alternate	2	42	39	36	33	30	27	24
115,000	Standard	2	26	23	20	Not Recommended			
	Alternate	2	7	10	Not Recommended				
115,000	Standard	3	88	87	80	76	72	68	64
	Alternate	3	74	70	66	62	58	54	50

- 1) One 90° elbow should be secured to the combustion air intake connection.
- 2) Minimum requirement for each vent pipe is five (5) feet in length and one elbow/tee.
- 3) Tee used in the vent/flue termination must be included when determining the number of elbows in the piping system.
- 4) 3" diameter pipe can be used in place of 2" diameter pipe.
- 5) Increased Clearance Configurations using (2) 45 deg. Long Sweep elbows should be considered equivalent to one 90 deg. elbow.

Vent/Flue and Combustion Air Pipe Lengths and Diameters (95% Furnaces Only)

Refer to the following table for applicable length, elbows, and pipe diameter for construction of the vent/flue and combustion air intake pipe systems of a direct vent (dual pipe) installation. The number of elbows tabulated represents the number of elbows and/or tees in each (Vent/Flue & Combustion Air Intake) pipe. Elbows and/or tees used in the terminations must be included when determining the number of elbows in the piping systems.

PRODUCT DESIGN

If the combustion air intake pipe is to be installed above a finished ceiling or other area where dripping of condensate will be objectionable, insulation of the combustion air pipe may be required. Use 1/2" thick closed cell foam insulation such as Armaflex or Insultube where required.

AMH9, GMH9, AMS95, GMS95

Direct Vent (Dual Pipe) Maximum Allowable Length of Vent/Flue & Combustion Air Intake Pipe (ft)										
Unit Input (Btu)	Vent/Flue/Air Intake Termination	Pipe Size ⁽⁴⁾ (in.)	Number of Elbows ⁽¹⁾⁽²⁾⁽³⁾⁽⁵⁾							
			2	3	4	5	6	7	8	
045_3	Standard	2	68	65	62	59	56	53	50	
	Alternate	2	55	52	49	46	43	40	37	
070_3	Standard	2	68	65	62	59	56	53	50	
	Alternate	2	55	52	49	46	43	40	37	
070_4	Standard	2	46	43	40	Not Recommended				
	Alternate	2	33	30	27	Not Recommended				
090_4	Standard	3	68	65	62	59	56	53	50	
	Alternate	3	55	52	49	46	43	40	37	
090_5	Standard	3	68	65	62	59	56	53	50	
	Alternate	3	55	52	49	46	43	40	37	
115_5	Standard	3	68	65	62	59	56	53	50	
	Alternate	3	55	52	49	46	43	40	37	

- 1) Minimum requirement for each vent pipe is five (5) feet in length and one elbow/tee.
- 2) Tees and/or elbows used in the vent/flue termination must be included when determining the number of elbows in the piping system.
- 3) 3" diameter pipe can be used in place of 2" diameter pipe.
- 4) Increased Clearance Configurations using (2) 45 deg. Long Sweep elbows should be considered equivalent to one 90 deg. elbow.

GKS9

Direct Vent (Dual Pipe) Maximum Allowable Length of Vent/Flue & Combustion Air Intake Pipe (ft)										
Unit Input (Btu)	Vent/Flue/Air Intake Termination	Pipe Size ⁽⁴⁾ (in.)	Number of Elbows ⁽¹⁾⁽²⁾⁽³⁾⁽⁵⁾							
			2	3	4	5	6	7	8	
045_3	Standard	2	68	65	62	59	56	53	50	
	Alternate	2	55	52	49	46	43	40	37	
070_3	Standard	2	36	33	30	27	24	21	18	
	Alternate	2	23	20	17	14	11	8	5	
	Standard	3	68	65	62	59	56	53	50	
	Alternate	3	55	52	49	46	43	40	37	
070_4	Standard	2	55	52	49	46	43	40	37	
	Alternate	2	42	39	36	33	30	27	24	
090_4	Standard	2	37	34	31	28	25	22	19	
	Alternate	2	24	21	18	15	12	9	6	
	Standard	3	68	65	62	59	56	53	50	
	Alternate	3	55	52	49	46	43	40	37	
090_5	Standard	2	39	36	33	30	27	24	21	
	Alternate	2	26	23	20	17	14	11	8	
	Standard	3	68	65	62	59	56	53	50	
	Alternate	3	55	52	49	46	43	40	37	
115_5	Standard	3	68	65	62	59	56	53	50	
	Alternate	3	55	52	49	46	43	40	37	

- 1) Elbows and/or tees used in terminations must be included when determining quantity of allowable elbows in the system.
- 2) Number of elbows tabulated are for each (Vent/Flue & Combustion Air Intake) pipe.
- 3) Minimum requirements for each Vent/Flue & Combustion Air Intake pipe is five (5) feet in length and one elbow/tee.
- 4) 3" diameter pipe can be used in place of 2" diameter pipe.
- 5) Increased Clearance Configurations using (2) 45 deg. Long Sweep elbows should be considered equivalent to one 90 deg. elbow.

ACV9, AMV9, GCV9, GMV9, GMV95

UPFLOW Direct Vent (Dual Pipe) Maximum Allowable Length of Vent/Flue & Combustion Air Intake Pipe (ft)										
Unit Input (Btu)	Termination Style	Pipe ⁽⁴⁾ (inch)	Number of Elbows ⁽¹⁾⁽²⁾⁽³⁾⁽⁵⁾							
			1	2	3	4	5	6	7	8
45,000	Standard	2	71	68	65	62	59	56	53	50
	Alternate	2	58	55	52	49	46	43	40	37
70,000	Standard	2	49	46	43	40	37	34	31	28
		3	71	68	65	62	59	56	53	50
	Alternate	2	36	33	30	27	24	21	18	15
		3	57	54	51	48	45	42	39	36
90,000	Standard	3	71	68	65	62	59	56	53	50
	Alternate	3	57	54	51	48	45	42	39	36
115,000	Standard	3	49	46	43	40	37	34	31	28
	Alternate	3	35	32	29	26	23	20	17	14

COUNTERFLOW Direct Vent (Dual Pipe) Maximum Allowable Length of Vent/Flue & Combustion Air Intake Pipe (ft)										
Unit Input (Btu)	Termination Style	Pipe ⁽⁴⁾ (inch)	Number of Elbows ⁽¹⁾⁽²⁾⁽³⁾⁽⁵⁾							
			1	2	3	4	5	6	7	8
70,000	Standard	2	49	46	43	40	37	34	31	28
		3	71	68	65	62	59	56	53	50
	Alternate	2	36	33	30	27	24	21	18	15
		3	57	54	51	48	45	42	39	36
90,000	Standard	2	61	58	55	52	49	46	43	40
		3	71	68	65	62	59	56	53	50
	Alternate	2	48	45	42	39	36	33	30	27
		3	57	54	51	48	45	42	39	36

- 1) Elbows and/or tees used in terminations must be included when determining quantity of allowable elbows in the system.
- 2) Number of elbows tabulated are for each (Vent/Flue & Combustion Air Intake) pipe.
- 3) Minimum requirements for each Vent/Flue & Combustion Air Intake pipe is five (5) feet in length and one elbow/tee.
- 4) 3" diameter pipe can be used in place of 2" diameter pipe.
- 5) Increased Clearance Configurations using (2) 45 deg. Long Sweep elbows should be considered equivalent to one 90 deg. elbow.

Vent/Flue and Combustion Air Pipe Terminations

VENT/FLUE AND COMBUSTION AIR PIPE TERMINATIONS

The vent/flue and combustion air pipes may terminate vertically, as through a roof, or horizontally, as through an outside wall.

PRODUCT DESIGN

Vertical pipe terminations should be as shown in the following figure. Refer to Section IX, *Vent/Flue Pipe and Combustion Pipe - Termination Locations* for details concerning location restrictions. The penetrations through the roof must be sealed tight with proper flashing such as is used with a plastic plumbing vent.

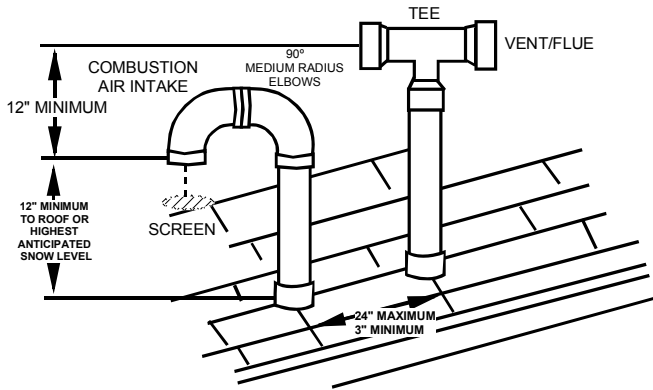

90% Furnace Vertical Terminations (Dual Pipe)

Horizontal terminations should be as shown in the following figure. Refer to *Vent/Flue Pipe and Combustion Pipe - Termination Location* section in this manual or the installation instructions for location restrictions. A 2 3/8" diameter wall penetration is required for 2" diameter pipe while a 3 1/2" diameter hole is required for 3" diameter pipe. To secure the pipe passing through the wall and prohibit damage to piping connections, a coupling should be installed on either side of the wall and solvent cemented to a pipe connecting the two couplings. The pipe length should be the wall thickness plus the depth of the socket fittings to be installed on the inside and outside of the wall. The wall penetration should be sealed with silicone caulking material.

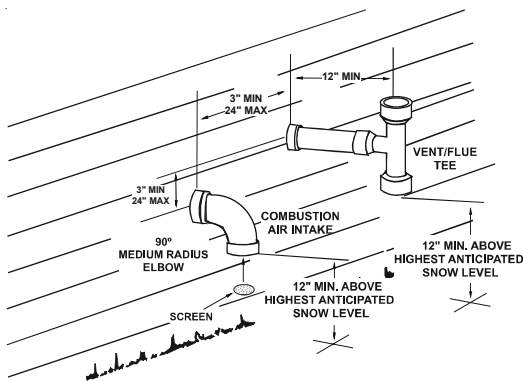

90% Standard Horizontal Terminations (Dual Pipe)

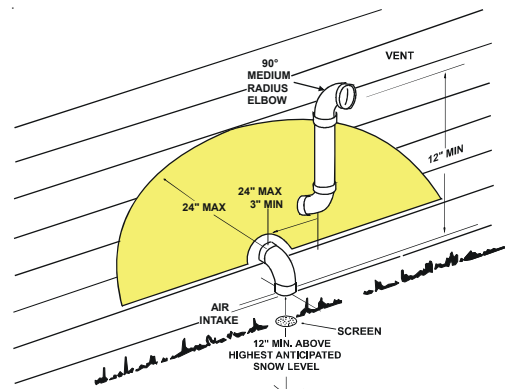

90% Alternate Horizontal Vent Termination (Dual Pipe)

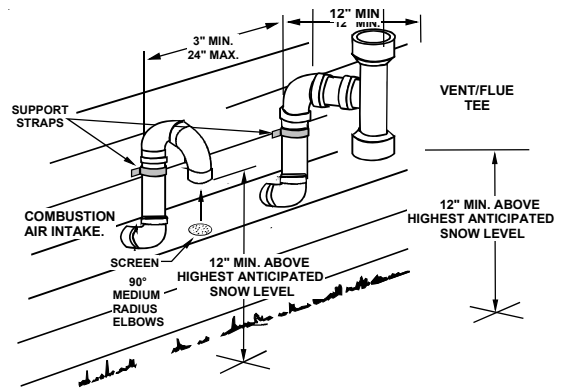

90% Furnace Standard Horizontal Terminations Above Anticipated Snow Level (Dual Pipe)

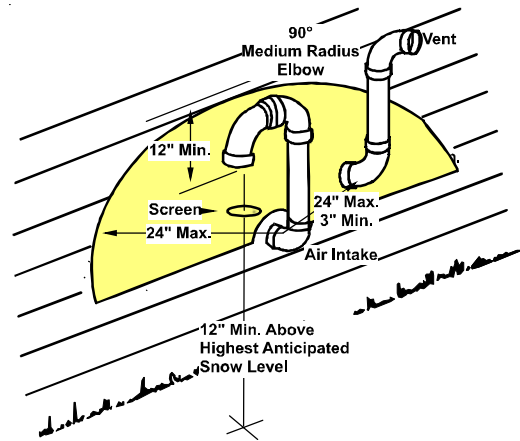

90% Furnace Alternate Vent Termination Above Anticipated Snow Level (Dual Pipe)

In a basement installation, the pipes may be run between the joist spaces. If the pipes must go below the joist and then up into the last joist space to penetrate the header, two 45° elbows should be used to reach the header rather than two 90° elbows.

PRODUCT DESIGN

VENT/INTAKE TERMINATIONS FOR INSTALLATION OF MULTIPLE DIRECT VENT FURNACES

If more than one direct vent furnace is to be installed vertically through a common roof top, maintain the same minimum clearances between the exhaust vent and air intake terminations of adjacent units as with the exhaust vent and air intake terminations of a single unit.

If more than one direct vent furnace is to be installed horizontally through a common side wall, maintain the clearances as in the following figure. Always terminate all exhaust vent outlets at the same elevation and always terminate all air intakes at the same elevation.

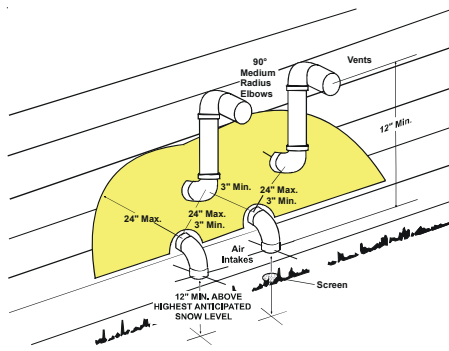

90% Furnace Horizontal Venting of Multiple Units (Dual Pipe)

Concentric Vent Kits (DCVK) Application

The DCVK-20 and DCVK-30 kit is designed to allow the terminations of a direct vent furnace to be “concentrically” vented through a wall or roof. This kit allows a single penetration to support terminations for both the vent/flue pipe and the combustion air intake pipe.

(DCVK) Vent Termination Clearances

1. Determine termination locations based on clearances specified in furnace installation instructions, and following steps as shown in Figures 1,3,6,7,8 and 9.

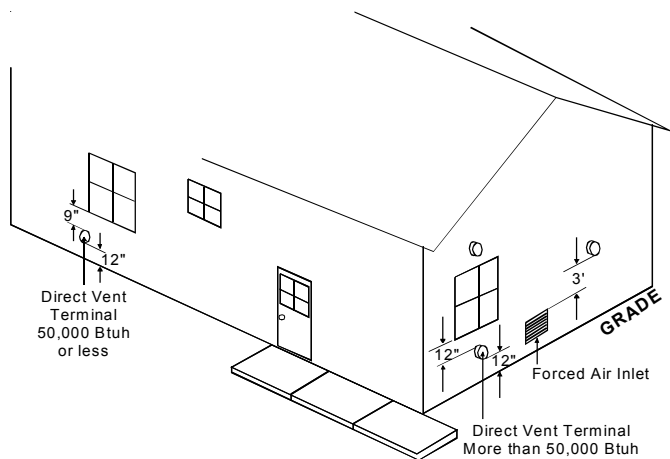

FIGURE 1

2. The vent termination must be located at least 12” above ground or normally expected snow accumulation levels.
3. Do NOT terminate over public walkways. Avoid areas where condensate may cause problems such as above planters, patios, or adjacent to windows where steam may cause fogging.
4. The vent termination shall be located at least 4’ horizontally from any electric meter, gas meter, regulator and any relief equipment. These distances apply ONLY to U.S. Installations.
5. The vent termination shall be located at least 3’ above any forced air inlet located within 10’; and at least 10’ from a combustion air intake of another appliance, except another direct vent furnace intake.
6. In Canada, the Canadian Fuel Gas Code takes precedence over the preceding termination instructions.

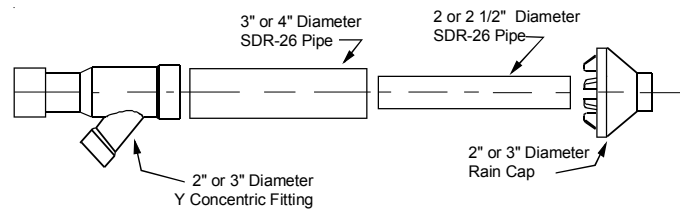

FIGURE 2

These kits are for vertical or horizontal termination of the combustion air inlet and the exhaust vent pipes on Category IV gas-fired condensing furnaces. The DCVK-30 kit can be used for 3” diameter pipe systems. The DCVK-20 kit can be used for the 2” diameter pipe system. Refer to Table 2 for the correct pipe size for the furnace. Both the combustion air inlet and the exhaust vent pipes must attach to the termination kit. The termination kit must terminate outside the structure and must be installed per the instructions outlined below for vertical or horizontal termination. Vertical termination is preferred. Field supplied pipe and fittings are required to complete the installation.

1. Determine the pipe diameters required for installation from Table 1. Do not include the field supplied 45° elbow in the total elbow count. If more than four elbows are required, reduce the length of both the inlet and the exhaust pipes five feet for each additional elbow used. Elbows are DWV long radius type for 2” and 3” vents.

NOTE: Feet of pipe is whichever pipe run is the longest, either the inlet or outlet side.

PRODUCT DESIGN

DCVK KITS

SINGLE STAGE FURNACE MAXIMUM ALLOWABLE LENGTH OF VENT AND COMBUSTION AIR PIPE FEET								
GAS INPUT RATE (Kbtu/hr)	PIPE DIAMETER	KIT NUMBER	Number of Elbows					
			2	3	4	5	6	7
45	2"	DCVK-20	55	52	49	46	43	40
70	2"	DCVK-20	55'	50'	45'	40'	NA	NA
90	3"	DCVK-30	54	51	48	45	42	39
115	3"	DCVK-30	55'	50'	45'	40'	NA	NA

TWO-STAGE FURNACE MAXIMUM ALLOWABLE LENGTH OF VENT AND COMBUSTION AIR PIPE FEET								
GAS INPUT RATE (Kbtu/hr)	PIPE DIAMETER	KIT NUMBER	Number of Elbows					
			2	3	4	5	6	7
45	2"	DCVK-20	55	52	49	46	43	40
70	2"	DCVK-20	33	30	27	24	21	18
70	3"	DCVK-30	54	51	48	45	42	39
90	3"	DCVK-30	54	51	48	45	42	39
115	3"	DCVK-30	32	29	26	23	20	17

TABLE 1

2. Determine the best location for the termination kit. See Figure 3 for vertical termination or Figure 6 and Figure 7 for horizontal termination. Roof termination is preferred since it is less susceptible to damage, has reduced intake contaminants and less visible vent vapors. For side termination, consideration should be given to:
 - a. Possible damage from the vapors to plants/shrubs, other equipment and building materials
 - b. Possible damage to the terminal from foreign objects
 - c. Wind effects that may cause recirculation of flue products, debris or light snow
 - d. Visible vent vapors.

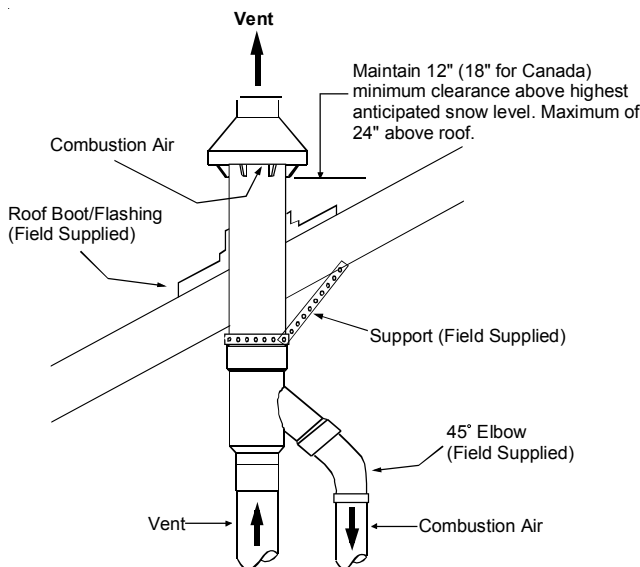

FIGURE 3

WARNING

DO NOT OPERATE THE FURNACE WITH THE RAIN CAP REMOVED AS RECIRCULATION OF THE FLUE GASES MAY OCCUR. WATER MAY ALSO COLLECT INSIDE THE LARGER COMBUSTION AIR PIPE AND FLOW TO THE BURNER ENCLOSURE. FAILURE TO FOLLOW THIS WARNING CAN RESULT IN PROPERTY DAMAGE, EQUIPMENT DAMAGE, PERSONAL INJURY OR DEATH.

6. Install the Y concentric fitting and the pipe assembly through the structure's opening. For vertical termination, install the parts through the field supplied roof boot/flashing. NOTE: Do not allow insulation or other materials to accumulate inside the pipe assembly when installing through the structure's opening.
7. Secure the assembly to the structure as shown in Figure 3 or Figure 7 using field supplied metal strapping or equivalent material.

NOTE:

- Ensure that the strap is installed to prevent movement of termination kit in side wall.
- Ensure the termination height is above the roof surface or anticipated snow level as shown in Figure 3 for vertical termination.
- Ensure the termination location clearance dimensions are as shown in Figure 6 and Figure 7 for horizontal termination.

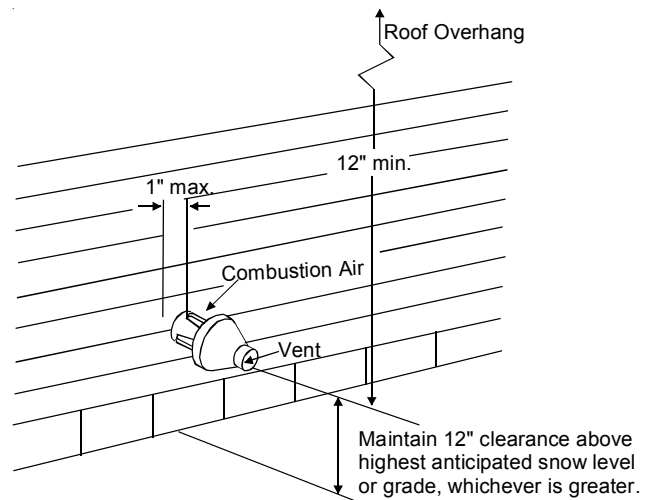

FIGURE 6

PRODUCT DESIGN

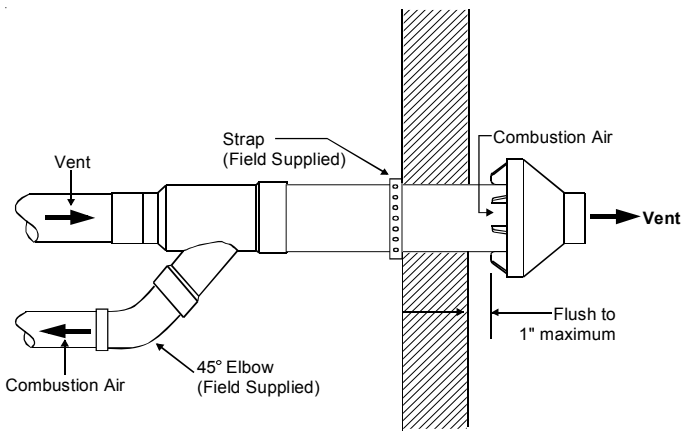
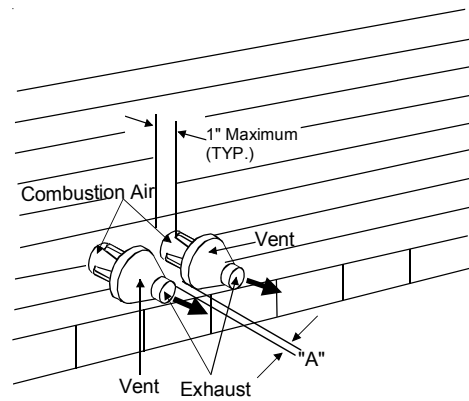

FIGURE 7



Dimension "A" is touching or 2" maximum separation.

FIGURE 9

8. Install the rain cap and the small diameter pipe assembly in the Y concentric fitting and the large pipe assembly. Ensure that the small diameter pipe is bottomed out and securely cemented in the Y concentric fitting.
9. Cement the furnace combustion air and vent pipes to the concentric vent termination assembly. See Figure 3 or Figure 7 for proper pipe attachment.
10. Operate the furnace through one heat cycle to ensure combustion air and vent pipes are properly connected to the concentric termination connections.

MULTI-VENT TERMINATION CLEARANCES

When two (2) or more furnaces are vented near each other, each furnace must be individually vented.

Two (2) vent terminations may be installed as shown in Figure 8 and Figure 9, but the next vent termination must be at least 36" away from first 2 terminations. It is important that vent terminations be made as shown to avoid recirculation of flue gases.

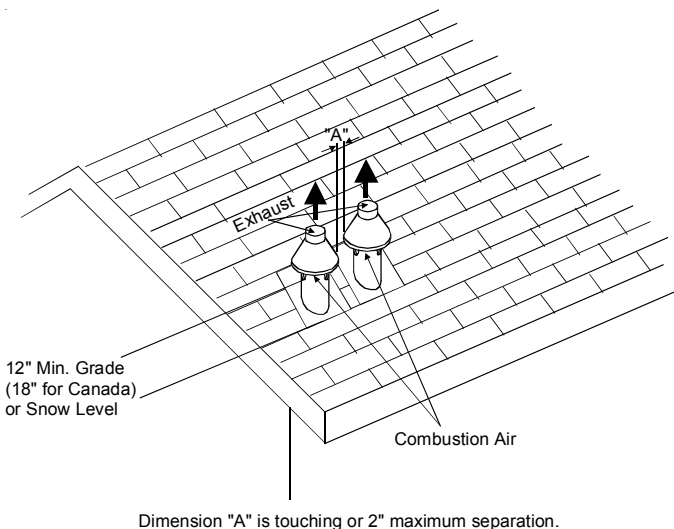

Dimension "A" is touching or 2" maximum separation.

FIGURE 8

Concentric Sidewall Vent Kit (0170K0000S)

This (sidewall only) vent kit is to be used with 2" or 3" vent systems. The vent kit must terminate outside the structure and may be installed with the intake and exhaust pipes located side-by-side or with one pipe above the other. This kit is NOT intended for use with single pipe (non-direct vent) installations.

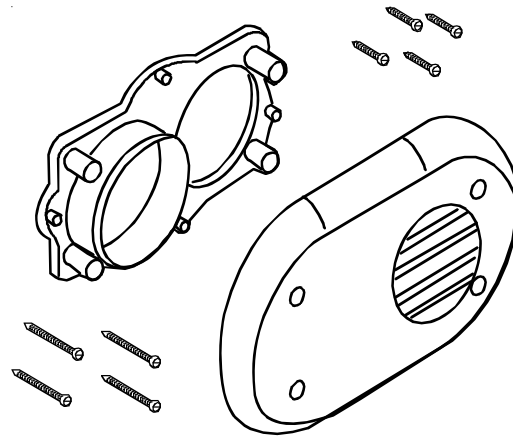

1. Determine the best location for the vent terminal. In addition to all applicable codes, consider the following when determining the location:
 - a. The vent terminal should be located so as to minimize the total length and number of elbows in the piping. Consult the furnace installation instructions for the pipe lengths and number of elbows allowed.
 - b. Terminal should be positioned where vent vapors will not damage plants, shrubs, air conditioning equipment or building materials.
 - c. Terminal should be located where it will not be affected by wind gusts, snow, airborne leaves or other debris, and where it will not allow recirculation of flue gases.

PRODUCT DESIGN

- d. Terminal should be located where it will not be damaged or exposed to foreign objects such as stones, balls, etc.
- e. Terminal should be located where vent vapors are not objectionable.
2. Using the vent terminal base as a template, locate the pipe holes and the four mounting screw holes on the wall.
3. Cut two 3 7/8" diameter holes for the vent and intake pipes.
4. Drill four 3/16" diameter holes for inserting the plastic screw anchors into the wall.

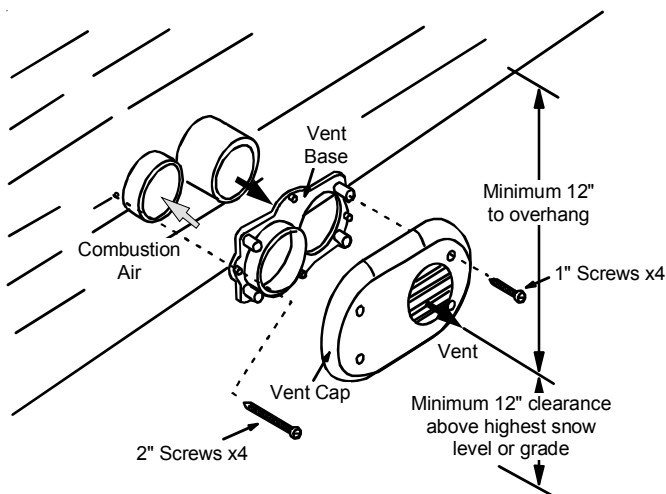

5. Insert the four plastic screw anchors into the screw holes and mount the vent terminal base to the wall using the four 2" long screws provided.
6. Assemble the vent terminal cap to the vent terminal base, using four 1" long screws provided.
7. Install 3" diameter vent and air intake pipes into the back side of the openings in the vent terminal base.
8. Seal all gaps between the pipes and wall.
9. Using RTV silicone sealant, seal the vent pipe to the vent cap. This will allow the terminal to be disassembled later if necessary for cleaning. **DO NOT** use PVC solvent cement to seal this connection.

NOTE: To downsize the piping to 2" diameter, use a field-supplied reducing coupling.

10. Operate the furnace for 15 minutes to ensure that it is working properly and that all piping joints are sealed to prevent the escape of combustion products into the home.
11. For installations where two or more furnaces are to be vented using this kit, ensure a minimum clearance of 1" between the vent terminal caps. To prevent condensate freezing problems, do not install multiple vent kits above one another.

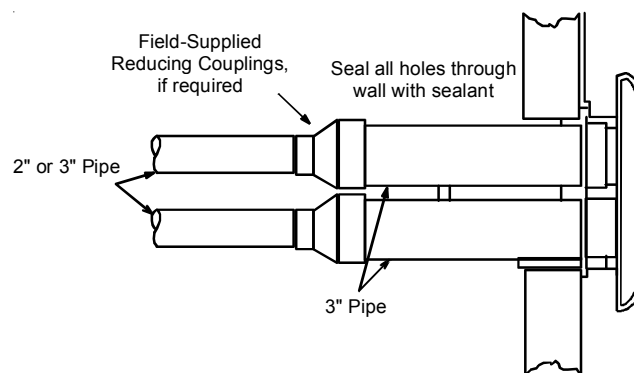

Condensate Drain Lines and Drain Trap (90% Furnaces Only)

A condensing gas furnace achieves its high level of efficiency by extracting almost all of the heat from the products of combustion and cooling them to the point where condensation takes place. The condensate which is generated must be piped to an appropriate drain location.

In *upright* installations, the furnace's drain hoses may exit either the right or left side of the furnace. **NOTE:** If the alternate vent/flue outlet is utilized in an upright installation, the drain trap and drain connections must be located on the same side as the alternate vent/flue outlet.

In *horizontal* installations, the drain hoses will exit through the bottom (down side) of the unit with the drain trap suspended beneath the furnace. The field-supplied drain system must be in accordance with all local codes and the instructions in the following sections.

WARNING

IN UPRIGHT UPFLOW INSTALLATIONS, THE DRAIN TRAP MUST BE MOUNTED ON THE OPPOSITE SIDE OF THE UNIT FROM THE JUNCTION BOX. THIS WILL REDUCE THE RISK OF WATER REACHING THE JUNCTION BOX IN THE EVENT OF A BLOCKED DRAIN CONDITION. FAILURE TO FOLLOW THESE INSTRUCTIONS CAN RESULT IN POSSIBLE PROPERTY DAMAGE, PERSONAL INJURY, OR DEATH DUE TO ELECTRICAL SHOCK.

Follow the bullets listed below when installing the drain system. Refer to the following sections for specific details concerning furnace drain trap installation and drain hose hook ups.

- The drain trap supplied with the furnace must be used.
- The drain line between furnace and drain location must be constructed of 3/4" PVC or CPVC.
- The drain line between furnace and drain location must maintain a 1/4" per foot downward slope toward the drain.
- Do not trap the drain line in any other location than at the drain trap supplied with the furnace.
- Do not route the drain line outside where it may freeze.

PRODUCT DESIGN

- If the drain line is routed through an area which may see temperatures near or below freezing, precautions must be taken to prevent condensate from freezing within the drain line.
- If an air conditioning coil is installed with the furnace, a common drain may be used. An open tee must be installed in the drain line, near the cooling coil, to relieve positive air pressure from the coil's plenum. This is necessary to prohibit any interference with the function of the furnace's drain trap.

UPRIGHT INSTALLATIONS

In an upright installation drain hoses are connected to drain ports on the rubber elbow and the recuperator coil front cover. The drain lines are then routed through the right or left side panel and into the drain trap secured to the outside of the cabinet.

NOTE: Refer to *Condensate Drain Lines and Drain Trap - Alternate Vent/Flue Hose Connections* section in this manual or the installation instructions for upright installations using an alternate vent/flue outlet.

Standard Right or Left Side Drain Hose Connections

Upright installations using the *standard* vent/flue outlet require drain hoses to be connected as shown in the following figures.

NOTE: For left side drainage, grommets will have to be relocated to left side panel.

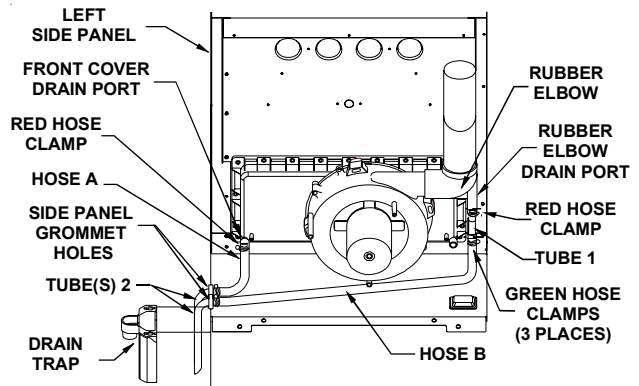

**90% Furnace Upright "Standard"
Drain Hose Connections (Left Side)**

NOTE: Ensure hoses and tubes maintain a downward slope for proper drainage and that they are not kinked or binding.

Alternate Vent/Flue Drain Hose Connections

Upright installations using the *alternate* vent/flue outlet will require "right-side only" drain hoses to be connected as shown in the following figure. Refer to *Vent/Flue Pipe and Combustion Air Pipe* section in this manual or the installation instructions for details on alternate vent/flue pipe connection.

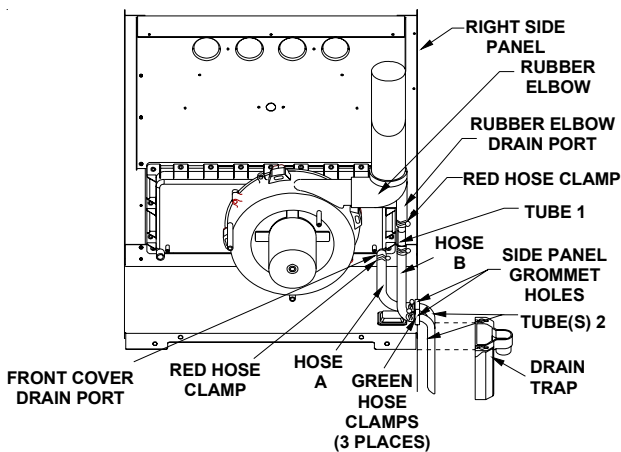

**90% Furnace Upright "Standard"
Drain Hose Connections (Right Side)**

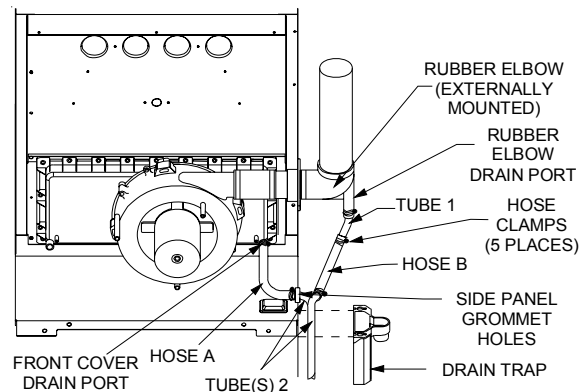

**90% Furnace Upright "Alternate"
Drain Hose Connections (Right Side Only)**

NOTE: Ensure hoses and tubes maintain a downward slope for proper drainage and are not kinked or binding.

For details concerning mounting of the drain trap, refer to the following section.

Upright Drain Trap Mounting (Left or Right Side Panel)

1. Insert drain tubes into drain trap and position the drain trap against the side panel. **NOTE:** Drain tubes must reach the bottom of the drain trap.
2. Secure drain trap to side panel at the mounting holes located below the grommet drain holes.

PRODUCT DESIGN

3. Attach PVC drain line to drain trap outlet with either a 90° elbow or coupling.

NOTE: Ensure hoses and tubes maintain a downward slope for proper drainage and that they are not kinked or binding.

Horizontal Installations

RIGHT SIDE DOWN

Horizontal installations with the right side down require that the drain hoses be connected to the right side front cover drain port and the rubber elbow drain port.

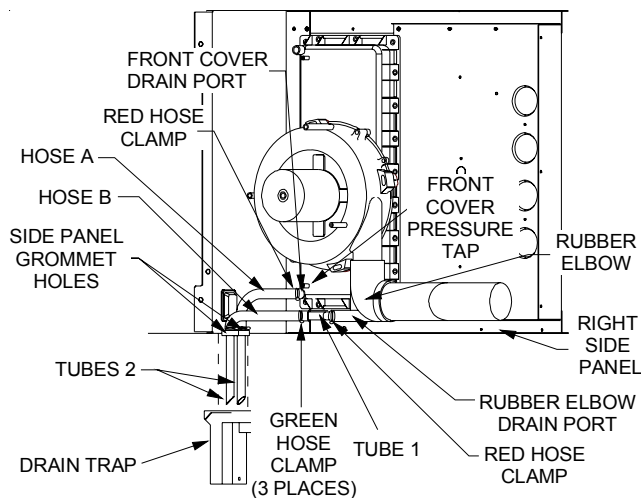

**90% Furnace Horizontal
Drain Hose Connections (Right Side Down)**

NOTE: Ensure hoses and tubes maintain a downward slope for proper drainage and are not kinked or bound.

For details concerning mounting of the drain trap, refer to *Condensate Drain Lines and Drain Trap - Horizontal Drain Trap Mounting* section in this manual or the installation instructions.

LEFT SIDE DOWN

Horizontal installations with the left side panel down will require drain hoses to be connected to the left side front cover drain port and the induced draft blower drain port.

NOTE: Relocation of the front cover pressure switch hose is required from the right side (as shipped) pressure tap to the left (down) side tap. The pressure switch hose must be connected to the down side to guard against blocked drain conditions. The hose must be cut to appropriate length to minimize sagging.

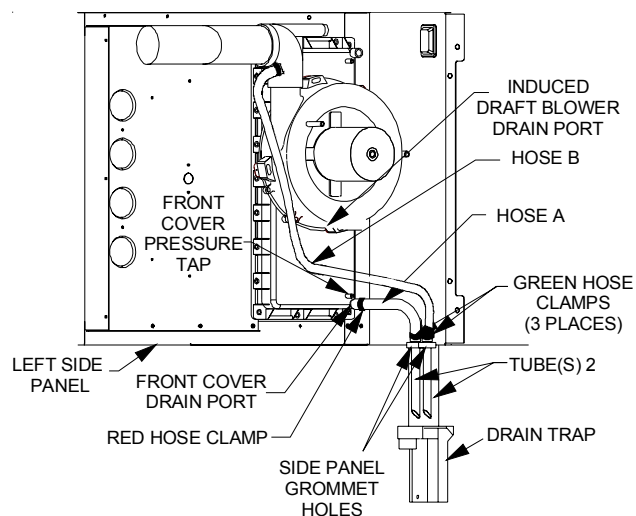

**90% Furnace Horizontal
Drain Hose Connections (Left Side Down)**

NOTE: Ensure hoses and tubes maintain a downward slope for proper drainage and that they are not kinked or binding. For details concerning mounting of the drain trap, refer to *Condensate Drain Lines and Drain Trap - Horizontal Drain Trap Mounting* in this manual or the installation instructions.

Horizontal Drain Trap Mounting (Left or Right Side Panel)

1. Position the drain trap against side panel with drain tubes inserted into trap. Note that the trap may be orientated with the outlet facing either the furnace's top cover or base pan.
2. Secure drain trap to side panel at the dimples or crosshairs located on either side of the grommet drain holes.
3. Confirm that tubes reach bottom of drain trap and that all hoses maintain a downward slope and are not kinked or binding.
4. Attach PVC drain line to drain trap outlet with either a 90° elbow or coupling.

GAS SUPPLY AND PIPING

The furnace rating plate includes the approved furnace gas input rating and gas types. The furnace must be equipped to operate on the type of gas applied. This includes any conversion kits required for alternate fuels and/or high altitude.

PRODUCT DESIGN



CAUTION

TO PREVENT UNRELIABLE OPERATION OR EQUIPMENT DAMAGE, THE INLET GAS SUPPLY PRESSURE MUST BE AS SPECIFIED ON THE UNIT RATING PLATE WITH ALL OTHER HOUSEHOLD GAS FIRED APPLIANCES OPERATING.

Inlet gas supply pressures must be maintained within the ranges specified below. The supply pressure must be constant and available with all other household gas fired appliances operating. The minimum gas supply pressure must be maintained to prevent unreliable ignition. The maximum must not be exceeded to prevent unit overfiring.

Inlet Gas Supply Pressure	
Natural Gas	Minimum: 5.0" W.C. Maximum :10.0" W.C.
Propane Gas	Minimum:11.0" W.C. Maximum :13.0" W.C.

HIGH ALTITUDE DERATE

When this furnace is installed at high altitude, the appropriate High Altitude orifice kit must be applied. This is required due to the natural reduction in the density of both the gas fuel and combustion air as altitude increases. The kit will provide the proper design certified input rate within the specified altitude range.

High altitude kits are purchased according to the installation altitude and usage of either natural or propane gas. Refer to the product Specification Sheet or Technical Manual for a tabular listing of appropriate altitude ranges and corresponding manufacturer's high altitude (Natural, Propane gas, and/or Pressure Switch) kits.

Do **not** derate the furnace by adjusting the manifold pressure to a lower pressure than specified on the furnace rating plate. The combination of the lower air density and a lower manifold pressure will prohibit the burner orifice from drawing the proper amount of air into the burner. This may cause incomplete combustion, flashback, and possible yellow tipping.

In some areas the gas supplier may artificially derate the gas in an effort to compensate for the effects of altitude. If the gas is artificially derated, the appropriate orifice size must be determined based upon the BTU/ft³ content of the derated gas and the altitude. Refer to the National Fuel Gas Code, NFPA 54/ANSI Z223.1, and information provided by the gas supplier to determine the proper orifice size.

A different pressure switch may be required at high altitude regardless of the BTU/ft³ content of the fuel used. Refer to the product Specification Sheet or Technical Manual for a tabular listing of appropriate altitude ranges and corresponding manufacturer's pressure switch kits.

PROPANE GAS CONVERSION



WARNING

POSSIBLE PROPERTY DAMAGE, PERSONAL INJURY OR DEATH MAY OCCUR IF THE CORRECT CONVERSION KITS ARE NOT INSTALLED. THE APPROPRIATE KITS MUST BE APPLIED TO INSURE SAFE AND PROPER FURNACE OPERATION. **ALL CONVERSIONS MUST BE PERFORMED BY A QUALIFIED INSTALLER OR SERVICE AGENCY.**

This unit is configured for natural gas. The appropriate manufacturer's propane gas conversion kit, must be applied for propane gas installations. The single-stage 80% and 90% furnaces use LPT-00A LP Conversion Kit. The two-stage 80% and 90% furnace models using a White-Rodgers 36E54 two-stage valve require an LPM-03B LP conversion kit. Two-stage 80% and 90% furnace models using a White-Rodgers 36G54 two-stage valve require an LPM-05 LP conversion kit. Refer to the specification sheet for the model you are servicing. Refer to the "propane gas and/or High Altitude Installations" section for details.

GAS VALVE

This unit is equipped with a 24 volt gas valve controlled during furnace operation by the integrated control module. As shipped, the valve is configured for natural gas. The valve is field convertible for use with propane gas by using the appropriate propane gas conversion kit. Taps for measuring the gas supply pressure and manifold pressure are provided on the valve. **The gas supply pressure on White-Rodger "G" model gas valve, used on single stage furnaces, can be checked with a gas pressure test kit (Part #0151K0000S) available through our authorized distributors.**

The gas valve has a manual ON/OFF control located on the valve itself. This control may be set only to the "ON" or "OFF" position. Refer to the *Lighting Instructions Label* or the "Putting the Furnace Into Operation" section of this manual or the installation instructions for use of this control during start up and shut down periods.

GAS PIPING CONNECTIONS



CAUTION

TO AVOID POSSIBLE UNSATISFACTORY OPERATION OR EQUIPMENT DAMAGE DUE TO UNDERFIRING OF EQUIPMENT, USE THE PROPER SIZE OF NATURAL/PROPANE GAS PIPING NEEDED WHEN RUNNING PIPE FROM THE METER/TANK TO THE FURNACE.

PRODUCT DESIGN

When sizing a trunk line, be sure to include all appliances which will operate simultaneously when sizing a trunk line. The gas piping supplying the furnace must be properly sized based on the gas flow required, specific gravity of the gas, and length of the run. The gas line installation must comply with local codes, or in their absence, with the latest edition of the National Fuel Gas Code, NFPA 54/ANSI Z223.1.

Natural Gas Capacity of Pipe In Cubic Feet of Gas Per Hour (CFH)					
Length of Pipe in Feet	Nominal Black Pipe Size				
	1/2"	3/4"	1"	1 1/4"	1 1/2"
10	132	278	520	1050	1600
20	92	190	350	730	1100
30	73	152	285	590	980
40	63	130	245	500	760
50	56	115	215	440	670
60	50	105	195	400	610
70	46	96	180	370	560
80	43	90	170	350	530
90	40	84	160	320	490
100	38	79	150	305	460

(Pressure 0.5 psig or less and pressure drop of 0.3" W.C.; Based on 0.60 Specific Gravity Gas)

$$CFH = \frac{BTUH \text{ Furnace Input}}{\text{Heating Value of Gas (BTU/Cubic Foot)}}$$

To connect the furnace to the building's gas piping, the installer must supply a ground joint union, drip leg, manual shutoff valve, and line and fittings to connect to gas valve. In some cases, the installer may also need to supply a transition piece from 1/2" pipe to a larger pipe size.

The following stipulations apply when connecting gas piping. Refer to the following figures for typical gas line connections to the furnace.

1. Use black iron or steel pipe and fittings for the building piping.
2. Use pipe joint compound on male threads only. Pipe joint compound must be resistant to the action of the fuel used.
3. Use ground joint unions.
4. Install a drip leg to trap dirt and moisture before it can enter the gas valve. The drip leg must be a minimum of three inches long.
5. Install a 1/8" NPT pipe plug fitting, accessible for test gage connection, immediately upstream of the gas supply connection to the furnace.
6. Use two pipe wrenches when making connection to the gas valve to keep it from turning. The orientation of the gas valve on the manifold must be maintained as shipped from the factory.
7. Install a manual shutoff valve between the gas meter and unit within six feet of the unit. If a union is installed, the union must be downstream of the manual shutoff valve, between the shutoff valve and the furnace.
8. Tighten all joints securely.

9. Connect the furnace to the building piping by one of the following methods:
 - Rigid metallic pipe and fittings.
 - Semi-rigid metallic tubing and metallic fittings. Aluminum alloy tubing must not be used in exterior locations. In order to seal the grommet cabinet penetration, rigid pipe must be used to reach the outside of the cabinet. A semi-rigid connector to the gas piping may be used from there.
10. Use listed gas appliance connectors in accordance with their instructions. Connectors must be fully in the same room as the furnace.
11. Protect connectors and semi-rigid tubing against physical and thermal damage when installed. Ensure aluminum-alloy tubing and connectors are coated to protect against external corrosion when in contact with masonry, plaster, or insulation, or subjected to repeated wetting by liquids such as water (except rain water), detergents, or sewage.

 **CAUTION**

EDGES OF SHEET METAL HOLES MAY BE SHARP. USE GLOVES A PRECAUTION WHEN REMOVING HOLE PLUGS.

DIRECT/STANDARD INLET PIPING

When gas piping enters *directly* to the gas valve through the *standard* inlet hole (upflow through the right side panel), the installer must supply straight pipe with a ground joint union to reach the exterior of the furnace. **NOTE:** The rigid pipe must be long enough to reach the outside of the cabinet to seal the grommet cabinet penetration on 90% furnaces. A semi-rigid connector to the gas piping can be used outside the cabinet per local codes.

INDIRECT/ALTERNATE INLET PIPING

When gas piping enters *indirectly* to the gas valve through the *alternate* gas inlet hole the installer must supply the following fittings (starting from the gas valve) to reach the outside of the cabinet (**NOTE:** On the 90% furnaces the installer must swap the alternate inlet hole plug with the standard inlet grommet in order to seal the cabinet):

- Coupling.
- 90 degree elbow.
- 2 inch close nipple.
- 90 degree elbow.
- Straight pipe, with a ground joint union, to reach the exterior of the furnace. **NOTE:** The rigid pipe must be long enough to reach the outside of the cabinet so as to seal the grommet cabinet penetration on the 90% furnaces. A semi-rigid connector to the gas piping can be used outside the cabinet per local codes.

PRODUCT DESIGN

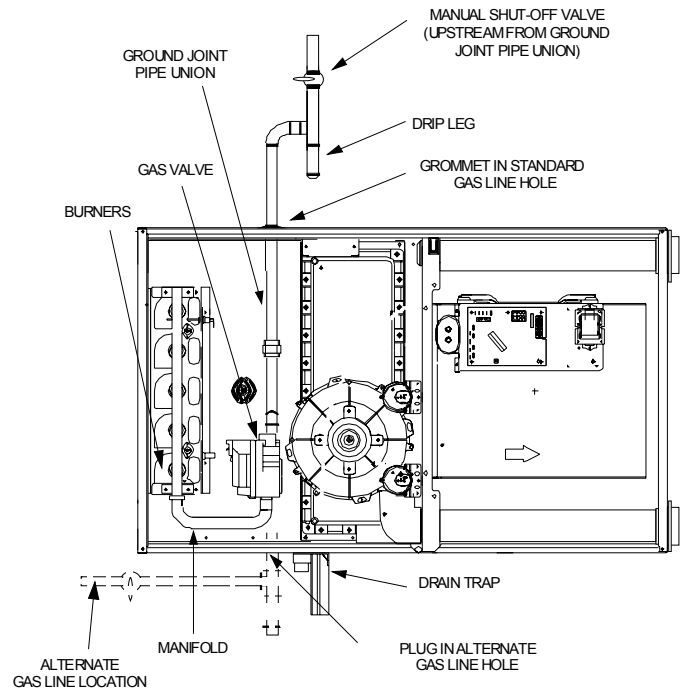
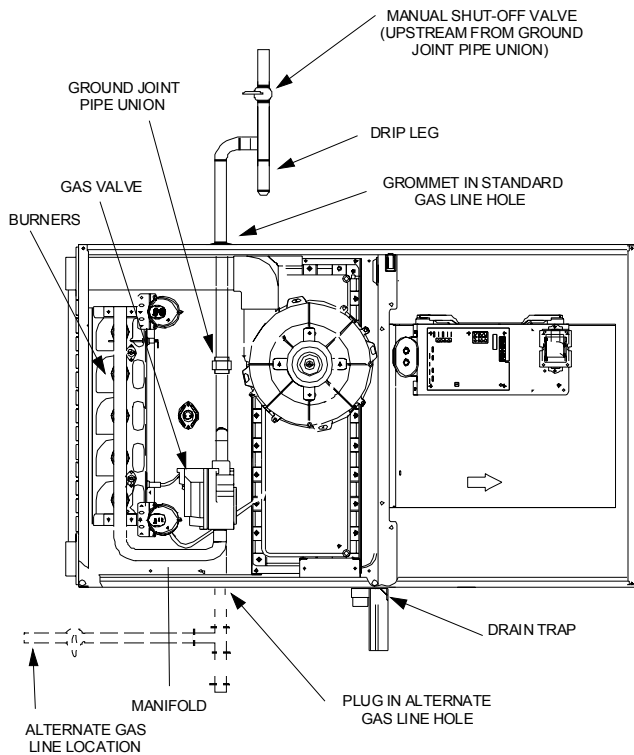
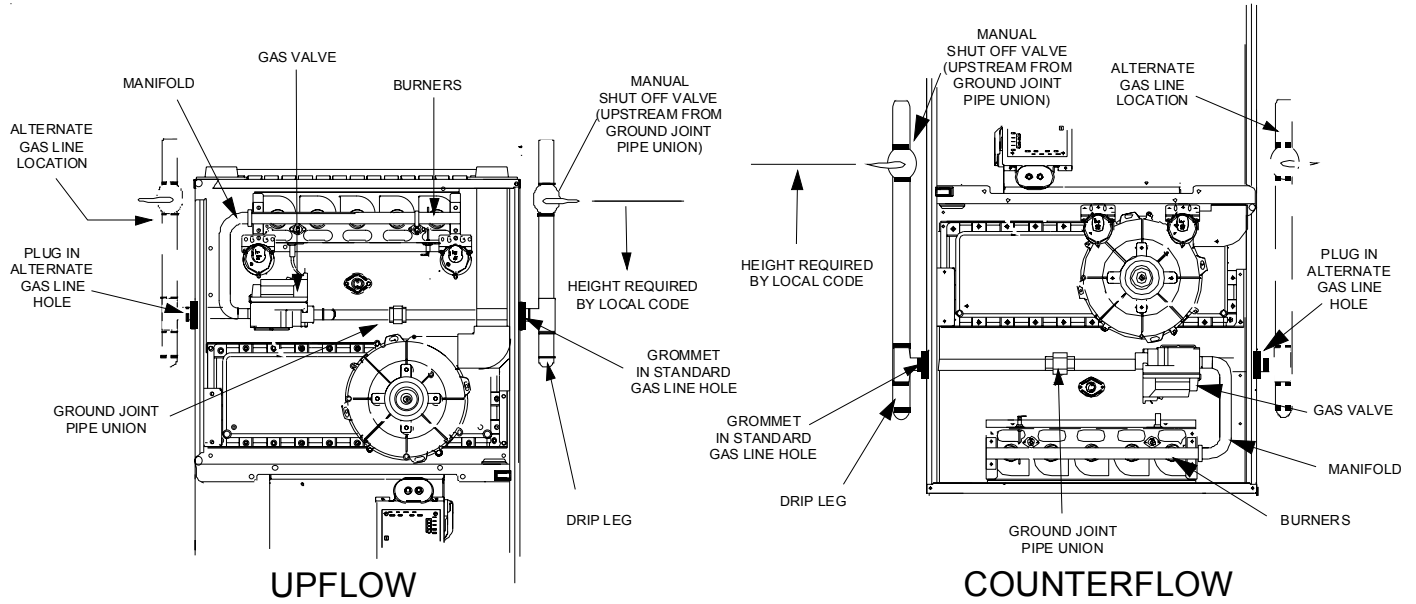

NOTES: 1. WHEN GAS LINE IS IN THE ALTERNATE LOCATION, SWAP THE POSITION OF THE PLUG AND GROMMET.

2. DRIP LEG MAY TERMINATE WITH A 1/2" X 1/8" PIPE PLUG TO ACCOMMODATE LINE GAS PRESSURE MEASUREMENT.

Gas Piping Connections
 (90% Furnace Shown, 80% Furnace Similar)

PRODUCT DESIGN

GAS PIPING CHECKS

Before placing unit in operation, leak test the unit and gas connections.



WARNING

TO AVOID THE POSSIBILITY OF EXPLOSION OR FIRE, NEVER USE A MATCH OR OPEN FLAME TO TEST FOR LEAKS.

Check for leaks using an approved chloride-free soap and water solution, an electronic combustible gas detector, or other approved testing methods.

NOTE: Never exceed specified pressures for testing. Higher pressure may damage the gas valve and cause subsequent overfiring, resulting in heat exchanger failure. Disconnect this unit and shutoff valve from the gas supply piping system before pressure testing the supply piping system with pressures in excess of 1/2 psig (3.48 kPa). Isolate this unit from the gas supply piping system by closing its external manual gas shutoff valve before pressure testing supply piping system with test pressures equal to or less than 1/2 psig (3.48 kPa).

PROPANE GAS TANKS AND PIPING



WARNING

PROPANE GAS IS HEAVIER THAN AIR AND ANY LEAKING GAS CAN SETTLE IN ANY LOW AREAS OR CONFINED SPACES. TO PREVENT PROPERTY DAMAGE, PERSONAL INJURY, OR DEATH DUE TO FIRE OR EXPLOSION CAUSED BY A PROPANE GAS LEAK, INSTALL A GAS DETECTION WARNING DEVICE.

A gas detecting warning system is the only reliable way to detect a propane gas leak. Iron oxide (rust) can reduce the level of odorant in propane gas. Do not rely on your sense of smell. Contact a local propane gas supplier about installing a gas detecting warning system. If the presence of gas is suspected, follow the instructions on Pages 19--22 of this manual.

All propane gas equipment must conform to the safety standards of the National Board of Fire Underwriters, NBFU Manual 58.

For satisfactory operation, propane gas pressure must be 11 inch WC at the furnace manifold with all gas appliances in operation. Maintaining proper gas pressure depends on three main factors:

1. Vaporization rate, depending on temperature of the liquid, and "wetted surface" area of the container or containers.
2. Proper pressure regulation. (Two-stage regulation is recommended for both cost and efficiency).
3. Pressure drop in lines between regulators, and between second stage regulator and the appliance. Pipe size will depend on length of pipe run and total load of all appliances.

Complete information regarding tank sizing for vaporization, recommended regulator settings, and pipe sizing is available from most regulator manufacturers and propane gas suppliers.

Since propane gas will quickly dissolve white lead and most standard commercial compounds, special pipe dope must be used. Shellac-based compounds resistant to the actions of liquefied petroleum gases such as Gasolac[®], Stalactic[®], Clyde's[®] or John Crane[®] are satisfactory.

Refer to the following illustration for typical propane gas installations and piping.

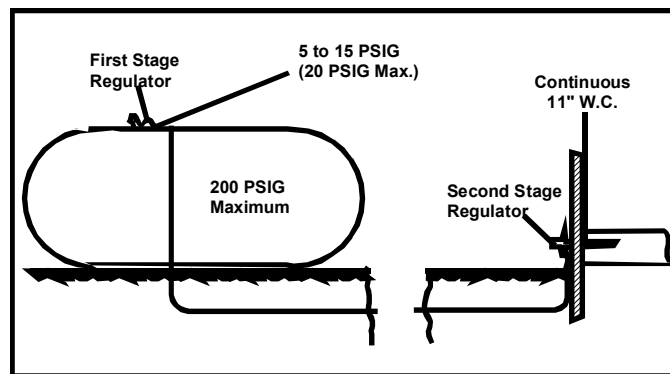

Typical Propane Gas Installation



WARNING

IF THE GAS FURNACE IS INSTALLED IN A BASEMENT, AN EXCAVATED AREA OR A CONFINED SPACE, IT IS STRONGLY RECOMMENDED TO CONTACT A PROPANE SUPPLIER TO INSTALL A GAS DETECTING WARNING DEVICE IN CASE OF A GAS LEAK.

- SINCE PROPANE GAS IS HEAVIER THAN AIR, ANY LEAKING GAS CAN SETTLE IN ANY LOW AREAS OR CONFINED SPACES.
- PROPANE GAS ODORANT MAY FADE, MAKING THE GAS UNDETECTABLE EXCEPT WITH A WARNING DEVICE.



WARNING

AN UNDETECTED GAS LEAK WILL CREATE A DANGER OF EXPLOSION OR FIRE. IF THE PRESENCE OF GAS IS SUSPECTED, FOLLOW THE INSTRUCTIONS ON THE COVER OF THIS MANUAL. FAILURE TO DO SO COULD RESULT IN **SERIOUS PERSONAL INJURY OR DEATH.**

PRODUCT DESIGN

WARNING

IF THE INFORMATION IN THESE INSTRUCTIONS IS NOT FOLLOWED EXACTLY, A FIRE OR EXPLOSION MAY RESULT CAUSING PROPERTY DAMAGE, PERSONAL INJURY OR LOSS OF LIFE.

- DO NOT STORE OR USE GASOLINE OR OTHER FLAMMABLE VAPORS AND LIQUIDS IN THE VICINITY OF THIS OR ANY OTHER APPLIANCE.
- **WHAT TO DO IF YOU SMELL GAS:**
 - DO NOT TRY TO LIGHT ANY APPLIANCE.
 - DO NOT TOUCH ANY ELECTRICAL SWITCH; DO NOT USE ANY PHONE IN YOUR BUILDING.
 - IMMEDIATELY CALL YOUR GAS SUPPLIER FROM A NEIGHBOR'S PHONE. FOLLOW THE GAS SUPPLIER'S INSTRUCTIONS.
 - IF YOU CANNOT REACH YOUR GAS SUPPLIER, CALL THE FIRE DEPARTMENT.
- INSTALLATION AND SERVICE MUST BE PERFORMED BY A QUALIFIED INSTALLER, SERVICE AGENCY OR THE GAS SUPPLIER.

Sizing Between First and Second Stage Regulator*

Maximum Propane Capacities listed are based on 2 psig pressure drop at 10 psig setting. Capacities in 1,000 BTU/hour.

Pipe or Tubing Length Feet	Tubing Size, O.D. Type L					Nominal Pipe Size Schedule 40	
	3/8"	1/2"	5/8"	3/4"	7/8"	1/2"	3/4"
10	730	1,700	3,200	5,300	8,300	3,200	7,500
20	500	1,100	220	3,700	5,800	2,200	4,200
30	400	920	2,000	2,900	4,700	1,800	4,000
40	370	850	1,700	2,700	4,100	1,600	3,700
50	330	770	1,500	2,400	3,700	1,500	3,400
60	300	700	1,300	2,200	3,300	1,300	3,100
80	260	610	1,200	1,900	2,900	1,200	2,600
100	220	540	1,000	1,700	2,600	1,000	2,300
125	200	490	900	1,400	2,300	900	2,100
150	190	430	830	1,300	2,100	830	1,900
175	170	400	780	1,200	1,900	770	1,700
200	160	380	730	1,100	1,800	720	1,500

To convert to capacities at 15 psig settings - multiply by 1.130

To convert to capacities at 5 psig settings - multiply by 0.879

Sizing Between Second or Second Stage Regulator & Appliance*

Maximum Propane Capacities listed are based on 1/2" W.C. pressure drop at 11" W.C. setting. Capacities in 1,000 BTU/hour.

Pipe or Tubing Length Feet	Tubing Size, O.D. Type L					Nominal Pipe Size Schedule 40				
	3/8"	1/2"	5/8"	3/4"	7/8"	1/2"	3/4"	1"	1-1/4"	1-1/2"
10	39	92	199	329	501	275	567	1,071	2,205	3,307
20	26	62	131	216	346	189	393	732	1,496	2,299
30	21	50	107	181	277	152	315	590	1,212	1,858
40	19	41	90	145	233	129	267	504	1,039	1,559
50	18	37	79	131	198	114	237	448	913	1,417
60	16	35	72	1,211	187	103	217	409	834	1,275
80	13	29	62	104	155	89	185	346	724	1,066
100	11	26	55	90	138	78	162	307	630	976
125	10	24	48	81	122	69	146	275	567	866
150	9	21	43	72	109	63	132	252	511	787
200	8	19	39	66	100	54	112	209	439	665
250	8	17	36	60	93	48	100	185	390	590

*Data in accordance with NFPA pamphlet No. 54

Propane Gas Piping Charts

When installing a propane storage tank, the contractor must consider proper tank sizing, safety, efficiency, ground characteristics and aesthetics. For a residential customer, the size may range from 100-1,000 gallons, depending on household use. Typically, a 500 gallon tank is ample for an average four-bedroom home. However, it is best to consult your local propane supplier to ensure the proper sizing for propane storage requirements. Determining the correct tank size for each household is a function of demand, economy, efficiency and convenience. It is a process that requires cooperation between the propane supplier and customer.

ELECTRICAL CONNECTIONS

WARNING

TO AVOID THE RISK OF ELECTRICAL SHOCK, WIRING TO THE UNIT MUST BE PROPERLY POLARIZED AND GROUNDED.

WARNING

HIGH VOLTAGE
DISCONNECT ALL POWER BEFORE SERVICING OR INSTALLING THIS UNIT. MULTIPLE POWER SOURCES MAY BE PRESENT. FAILURE TO DO SO MAY CAUSE PROPERTY DAMAGE, PERSONAL INJURY OR DEATH.



CAUTION

LABEL ALL WIRES PRIOR TO DISCONNECTION WHEN SERVICING CONTROLS. WIRING ERRORS CAN CAUSE IMPROPER AND DANGEROUS OPERATION. VERIFY PROPER OPERATION AFTER SERVICING.

WIRING HARNESS

The wiring harness is an integral part of this furnace. Field alteration to comply with electrical codes should not be required. Wires are color coded for identification purposes. Refer to the wiring diagram for wire routings. If any of the original wire as supplied with the furnace must be replaced, it must be replaced with wiring material having a temperature rating of at least 105° C. Any replacement wiring must be copper conductor.

115VOLT LINE CONNECTIONS

Before proceeding with electrical connections, ensure that the supply voltage, frequency, and phase correspond to that specified on the unit rating plate. Power supply to the furnace must be N.E.C. Class 1, and must comply with all applicable codes. The furnace must be electrically grounded in accordance with local codes or, in their absence, with the latest edition of The National Electric Code, ANSI NFPA 70 and/or The Canadian Electric Code CSA C22.1.

PRODUCT DESIGN

Use a separate fused branch electrical circuit containing properly sized wire, and fuse or circuit breaker. The fuse or circuit breaker must be sized in accordance with the maximum overcurrent protection specified on the unit rating plate. An electrical disconnect must be provided at the furnace location.

NOTE: Line polarity must be observed when making field connections.

! WARNING

IN 90% FURNACE UPRIGHT UPFLOW INSTALLATIONS, THE DRAIN TRAP MUST BE MOUNTED ON THE OPPOSITE SIDE OF THE UNIT FROM THE JUNCTION BOX. THIS WILL REDUCE THE RISK OF WATER REACHING THE JUNCTION BOX IN THE EVENT OF A BLOCKED DRAIN CONDITION.

Connect hot, neutral, and ground wires as shown in the wiring diagram located on the unit's blower door. Line polarity must be observed when making field connections. Line voltage connections can be made through either the right or left side panel.

The 80% and 90% furnaces are shipped configured for a left side electrical connection with the junction box located inside the burner compartment. To make electrical connections through the opposite side of the furnace, the junction box must be relocated to the other side of the burner compartment prior to making electrical connections, refer to the following figures.

! CAUTION

EDGES OF SHEET METAL HOLES MAY BE SHARP. USE GLOVES A PRECAUTION WHEN REMOVING HOLE PLUGS.

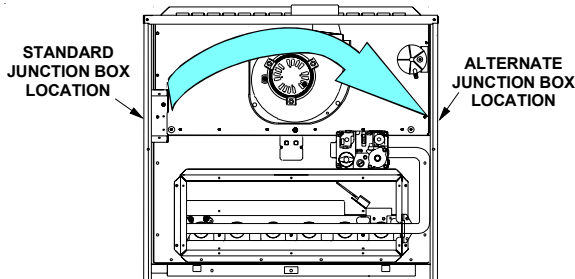

80% Furnace Junction Box Relocation

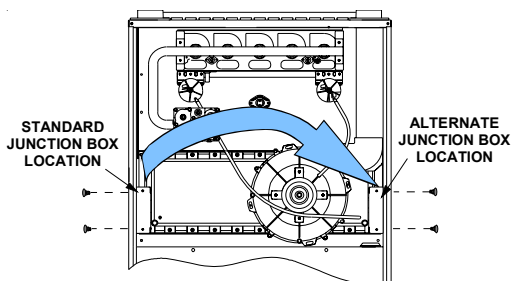

90% Furnace Junction Box Relocation

NOTE: Wire routing must not interfere with circulator blower operation, filter removal, or routine maintenance.

! WARNING

TO AVOID THE RISK OF ELECTRICAL SHOCK, INJURY, OR DEATH, THE FURNACE MUST BE ELECTRICALLY GROUNDED IN ACCORDANCE WITH LOCAL CODES OR, IN THEIR ABSENCE, WITH THE LATEST EDITION OF THE NATIONAL ELECTRIC CODE.

115 VOLT LINE CONNECTION OF ACCESSORIES (HUMIDIFIER AND ELECTRONIC AIR CLEANER)

! WARNING

HIGH VOLTAGE
DISCONNECT ALL POWER BEFORE SERVICING OR CHANGING ANY ELECTRICAL WIRING. MULTIPLE POWER SOURCES MAY BE PRESENT. FAILURE TO DO SO MAY CAUSE PROPERTY DAMAGE, PERSONAL INJURY OR DEATH.

All 80% & 90% furnaces have an integrated ignition control that is equipped with line voltage accessory terminals for controlling power to an optional field-supplied humidifier and/or electronic air cleaner.

Accessory Load Specifications	
Humidifier	1.0 Amp maximum at 120 VAC
Electronic Air Cleaner	1.0 Amp maximum at 120 VAC

Turn OFF power to the furnace before installing any accessories. Follow the humidifier or air cleaner manufacturers' instructions for locating, mounting, grounding, and controlling these accessories.

HUMIDIFIER WIRING

On 80% & 90% furnaces, accessory wiring connections are to be made through the 1/4" quick connect terminals provided on the furnace integrated control module. The Humidifier and Electronic Air Cleaner hot and neutral terminals are identified as HUM and EAC. All field wiring must conform to applicable codes. Connections should be made as shown below.

PRODUCT DESIGN

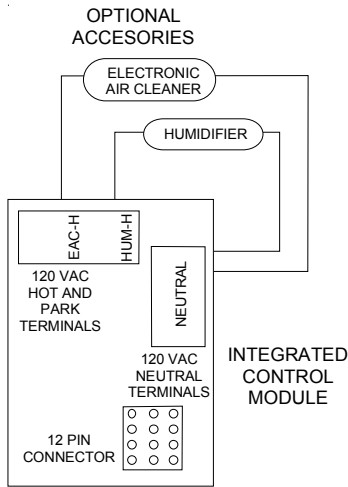

Accessory Wiring (WR50A65 Ignition Control Shown)

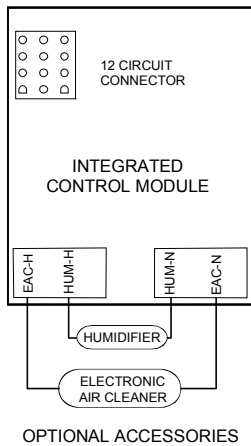

Accessory Wiring (WR50V-51 Ignition Control)

If it is necessary for the installer to supply additional line voltage wiring to the inside of the furnace, the wiring must conform to all local codes, and have a minimum temperature rating of 105°C. All line voltage wire splices must be made inside the furnace junction box.

The integrated control module humidifier terminals (HUM) are energized with 115 volts whenever the induced draft blower is energized. The integrated control module electronic air cleaner terminals (EAC) are energized with 115 volts whenever the circulator blower is energized.

24 VOLT THERMOSTAT WIRING

NOTE: Low voltage connections can be made through either the right or left side panel. Wire routing must not interfere with circulator blower operation, filter removal, or routine maintenance.

A 40 V.A. transformer and an integrated electronic control are built into the furnace to allow use with most cooling equipment. Consult the wiring diagram, located in the Technical Manual or on the blower door for further details of 115 Volt and 24 Volt wiring.

THERMOSTAT WIRING - 80% & 90% SINGLE-STAGE

The single stage furnace will have a "W" terminal and will use a single stage thermostat. The following drawing illustrates the typical field wiring for a heat only single stage system and a single stage heating/single stage cooling system. Refer to the following figures for proper connections to the integrated control module.

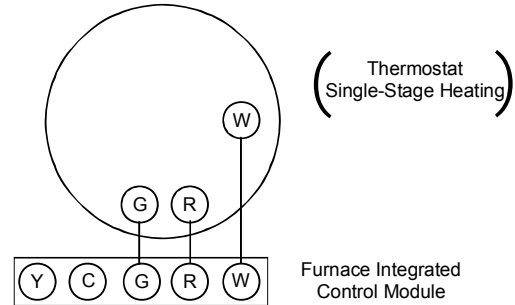

Single-Stage Heating Only

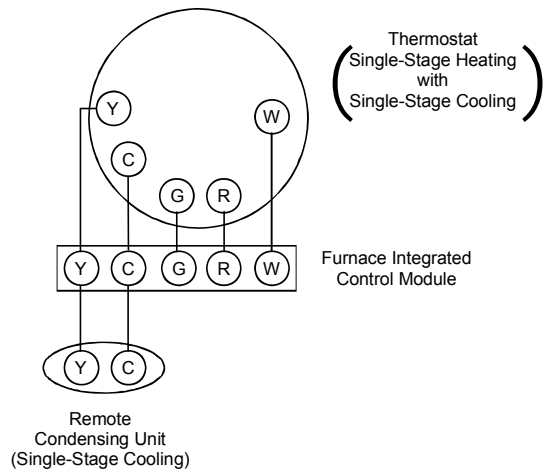

Single-Stage Heating with Single-Stage Cooling

Typical Field Wiring - Single-Stage Gas Furnaces (24 VAC Control Circuit)

Thermostat Wiring - 80% & 90%

Two-Stage Variable Speed Furnaces

As a two-stage furnace, the furnace integrated control module provides terminals for both "W1" and "W2", and "YLO" and "Y" thermostat connections. This allows the furnace to support the following system applications: 'Two-Stage Heating Only', 'Single-Stage Heating with Single-Stage Cooling', 'Two-Stage Heating with Single-Stage Cooling', and 'Two-Stage Heating with Two-Stage Cooling'. Refer to the following figures and table for proper connections to the integrated control module.

PRODUCT DESIGN

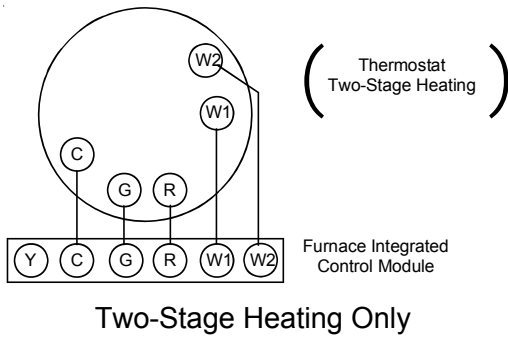

Typical Field Wiring - Two-Stage Gas Furnaces (24 VAC Control Circuit)

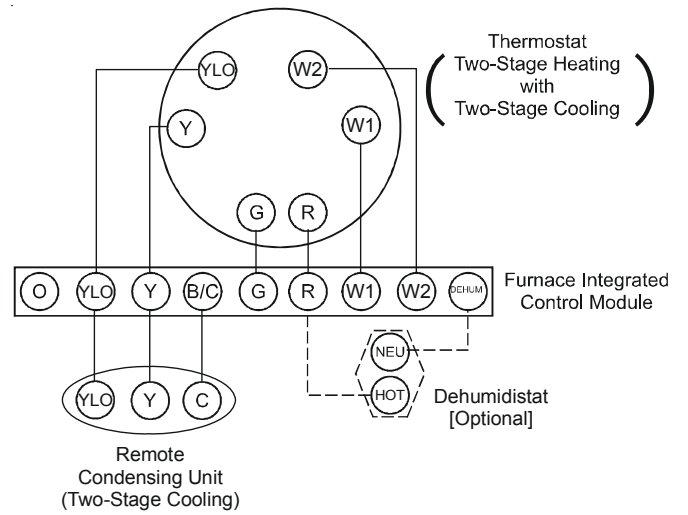

Typical Field Wiring Two-Stage Variable Speed Gas Furnaces (24VAC Control Circuit)

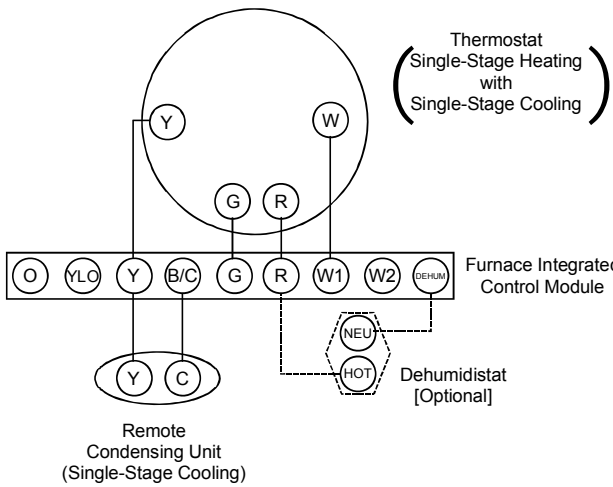

NOTE: To apply a single-stage heating thermostat, the thermostat selector jumper on the integrated Control module *must* be set on single stage.

Single-Stage Thermostat Application - 80% and 90% Variable Speed Two-Stage Furnaces

A single-stage thermostat with only one heating stage can be used to control this furnace. The application of a single-stage thermostat does not offer “true” thermostat-driven two-stage operation, but provides a *timed* transition from low to high stage. The furnace will run on low stage for a fixed period of time before stepping up to high stage to satisfy the thermostat’s call for heat. The delay period prior to stepping up can be set at either 5 or 10 minutes through the DIP switch adjacent to the Heat Off delay DIP switches on the integrated control module. To use a single-stage thermostat, turn off power to the furnace, move the thermostat selection jumper on the integrated control module from the “two-stage” position to the “single-stage” position, turn power back on. Refer to the following figures.

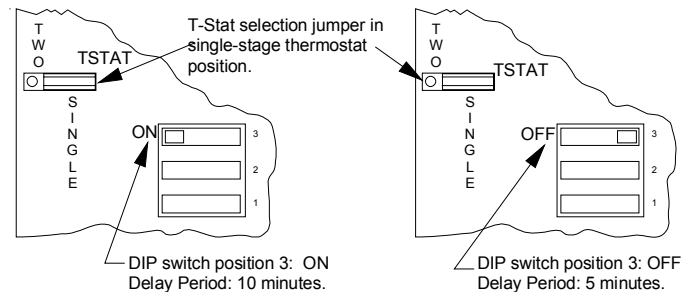

Single-Stage Thermostat Application

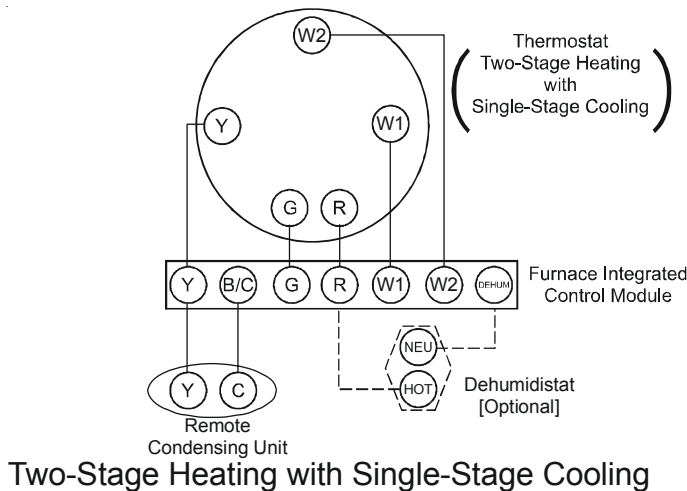

PRODUCT DESIGN

Thermostat Wiring Reference Chart (ADV8, AMV8, ACV9, AMV9, GMV8, GCV9, GMV9, GMV95) Two-Stage Variable Speed Furnace

Mode	Thermostat Connection		Connection Options		Furnace Circulator Blower Operation During Call From Thermostat
GENERAL	24 Volts HOT	R From Room Thermostat	To	R On Two-Stage Integrated Control Module	N/A
	24 Volts COMMON	C From Room Thermostat	To	C On Two-Stage Integrated Control Module	N/A
HEATING	Low Stage Connection For "Two-Stage" Heating	W1 From Room Thermostat	To	W1 On Two-Stage Integrated Control Module	Circulator blower will operate on <i>selected</i> Low Stage <u>Heating</u> speed tap
	High Stage Connection For "Two-Stage" Heating	W2 From Room Thermostat	To	W2 On Two-Stage Integrated Control Module	Circulator blower will operate on <i>selected</i> High Stage <u>Heating</u> speed tap
COOLING	Connection For "Single-Stage" Cooling	Y From Room Thermostat	To	Y On Two-Stage Integrated Control Module	Circulator blower will operate on <i>selected</i> High Stage <u>Cooling</u> speed tap (5 second "ON" delay and 45 second "OFF" delay)
	Low Stage Connection For "Two-Stage" Cooling	Y1 From Room Thermostat	To	Y-LO On Two Stage Integrated Control Module	Circulator blower will operate at 65% of <i>selected</i> High Stage <u>Cooling</u> speed tap
	High Stage Connection For "Two-Stage" Cooling	Y2 From Room Thermostat	To	Y On Two-Stage Integrated Control Module	Circulator blower will operate on <i>selected</i> High Stage <u>Cooling</u> speed tap (5 second "ON" delay and 45 second "OFF" delay)
CONTINUOUS FAN	Continuous Fan Connection [Any Application]	G From Room Thermostat	To	G On Two-Stage Integrated Control Module	Circulator blower will operate at 56% of selected High Stage Cooling Speed Tap

24 VOLT THERMOSTAT WIRING

NOTE: Wire routing must not interfere with circulator blower operation, filter removal, or routine maintenance. As a two-stage furnace, the furnace integrated control module provides terminals for both "W1" and "W2", and "YLO" and "Y" thermostat connections. This allows the furnace to support the following system applications: 'Two-Stage Heating Only', 'Two-Stage Heating with Single-Stage Cooling', and 'Two-Stage Heating with Two-Stage Cooling'. Refer to the following figures and table for proper connections to the integrated control module.

Low voltage connections can be made through either the right or left side panel. Thermostat wiring entrance holes are located in the blower compartment. The following figure shows connections for a "heat only" system and "heat/cool system".

This furnace is equipped with a 40 VA transformer to facilitate use with most cooling equipment. Consult the wiring diagram, located on the blower compartment door, for further details of 115 Volt and 24 Volt wiring.

PRODUCT DESIGN

SINGLE STAGE THERMOSTAT APPLICATION

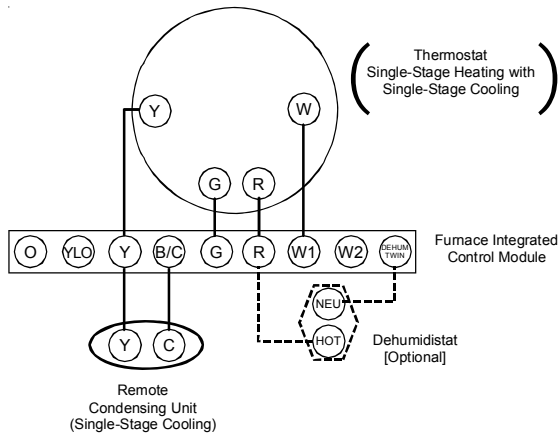

Single-Stage Heating with Single-Stage Cooling

NOTE: To apply a single-stage heating thermostat, the thermostat selector jumper on the integrated Control module must be set on single stage.

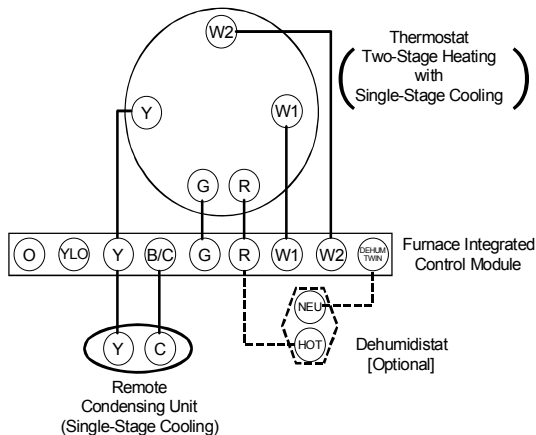

Two-Stage Heating with Single-Stage Cooling

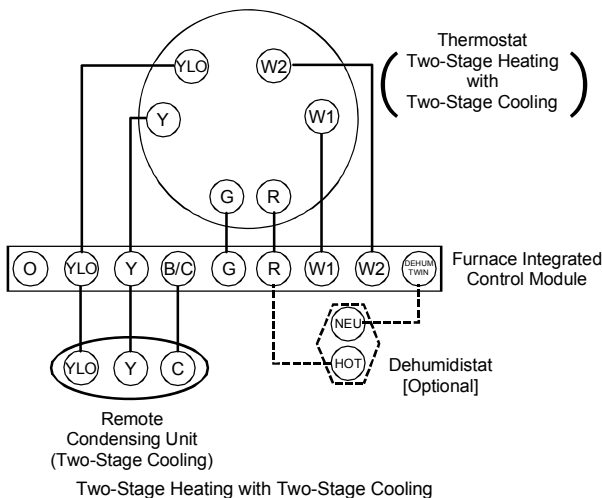

Two-Stage Heating with Two-Stage Cooling

24 Volt Dehumidistat Wiring - Two-Stage Variable Speed Gas Furnaces

The optional usage of a dehumidistat allows the furnace's circulator blower to operate at a slightly lower speed during a combined thermostat call for cooling and dehumidistat call for dehumidification. This lower blower speed enhances dehumidification of the conditioned air as it passes through the AC coil. For proper function, a dehumidistat applied to this furnace must operate on 24 VAC and utilize a switch which **opens on humidity rise**.

To install/connect a dehumidistat:

1. Turn OFF power to furnace.
 2. Secure the dehumidistat neutral wire (typically the white lead) to the screw terminal marked "DEHUM" on the furnace integrated control module.
 3. Secure the dehumidistat hot wire (typically the black lead) to the screw terminal marked "R" on the furnace integrated control module.
 4. Secure the dehumidistat ground wire (typically the green lead) to the ground screw on the furnace junction box.
- NOTE:** Ground wire may not be present on all dehumidistats.
5. Turn ON power to furnace.

To enable the dehumidify function on the circulator blower interface board:

1. Cut the jumper wire labeled "CUT FOR DEHUM" located adjacent to the DEHUM screw terminal. **NOTE: (W14 imprinted on the circuit board is the "CUT FOR DEHUM" location.)**

Once the jumper wire is cut, the dehumidify function is enabled during a *combination* call for cooling (T-Stat) and dehumidification (Dehum-Stat). The yellow LED adjacent to the DEHUM screw terminal will be illuminated during dehumidification.

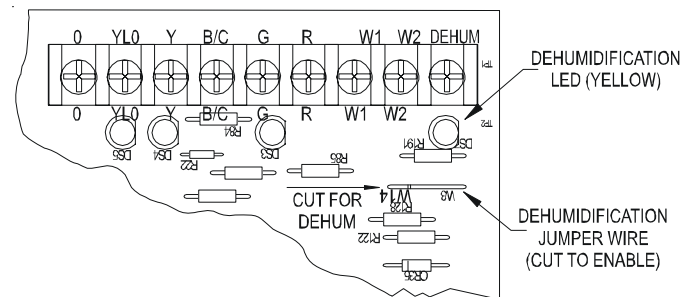

(50V51 and 50V61)
Integrated Ignition Control Module

PRODUCT DESIGN

Fossil Fuel Applications

The 80% & 90% Single-Stage and Two-Stage furnaces can be used in conjunction with a heat pump in a fossil fuel application. A fossil fuel application is where an outdoor temperature sensor determines the most cost efficient means of heating (heat pump, gas furnace, or both).

A heat pump thermostat with two stages of heat is required to properly use the single-stage furnace with a heat pump. A heat pump thermostat with three stages of heat is required to properly use the two-stage furnace with a heat pump. Refer to dual fuel, AFE-18-60A installation manual (10-627) for additional wiring instructions.

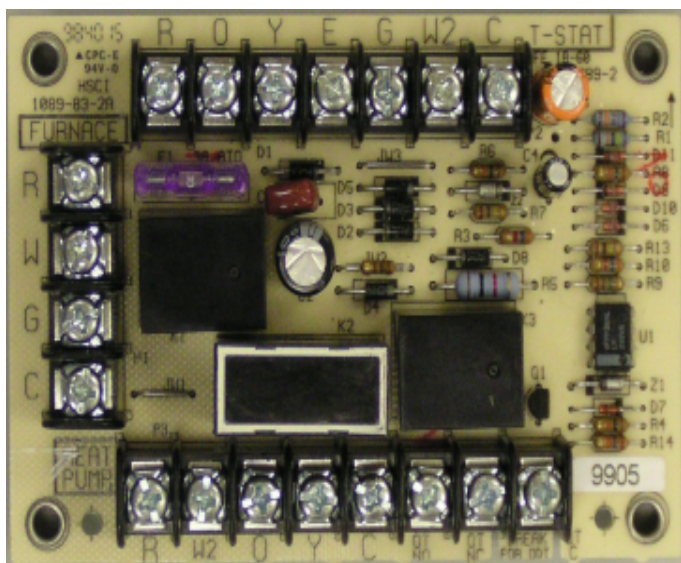

CONTINUOUS FAN OPERATION

SINGLE STAGE 80% AND 90% FURNACES

The single stage furnace control will energize the heating circulator fan speed when the fan switch on the thermostat is turned to the "ON" position.

TWO STAGE 80% & 90% VARIABLE SPEED FURNACES

The two stage furnace control will energize ECM blower motor when the fan switch on the thermostat is turned to the "ON" position. Continuous fan speed will be 56% of high stage cooling. This fan speed will provide circulation with less electricity than conventional single stage equipment.

CIRCULATOR BLOWER SPEED ADJUSTMENT

⚠ WARNING

HIGH VOLTAGE
DISCONNECT ALL POWER BEFORE CHANGING SPEED TAPS.
MULTIPLE POWER SOURCES MAY BE PRESENT. FAILURE TO DO
SO MAY CAUSE PROPERTY DAMAGE, PERSONAL INJURY OR DEATH.



All 80% & 90% single-stage and two-stage furnaces ship at high speed for cooling and the speeds listed in the Specification Sheet for heating. These speeds should be adjusted by the installer to match the job requirements. See Specification Sheet or Technical Manual for details.

Connect the correct motor leads to the COOL, HEAT, and PARK terminals. If the heating speed equals cooling speed, use the jumper wire provided. All unused motor leads that are not connected to "PARK" terminals on the control must be taped to prevent shorts.

All 80% & 90% Two-Stage Variable Speed furnaces are shipped with heating speed set at "B" and cooling speed set at "D". Use the following procedure to select the heating and cooling speed needed for your unit.

Use the "GREEN" CFM LED, adjacent to the integrated control module fuse to verify airflow quantity. The green CFM LED blinks once for each 100 CFM of airflow.

1. Determine the tonnage of the cooling system installed with the furnace. If the cooling capacity is in BTU/hr divide it by 12,000 to convert capacity to TONS.

EXAMPLE: Cooling Capacity of 30,000 BTU/hr.
 $30,000/12,000 = 2.5$ Tons

2. Determine the proper air flow for the cooling system. Most cooling systems are designed to work with air flows between 350 and 450 CFM per ton. Most manufacturers recommend an air flow of about 400 CFM per ton.

EXAMPLE: 2.5 tons X 400 CFM per ton = 1000 CFM

The cooling system manufacturer's instructions must be checked for required air flow. Any electronic air cleaners or other devices may require specific air flows, consult installation instructions of those devices for requirements.

3. Knowing the furnace model, locate the high stage cooling air flow charts in the Product Data Book applicable to your model. Look up the cooling air flow determined in step 2 and find the required cooling speed and adjustment setting.

EXAMPLE: A *MV90704CXA furnace installed with a 2.5 ton air conditioning system. The air flow needed is 1000 CFM. Looking at the cooling speed chart for *MV90704CXA, find the air flow closest to 1000 CFM. A cooling airflow of 990 CFM may be attained by setting the cooling speed to "C" and the adjustment to "-" (minus). **NOTE:** Continuous Fan Speed will be 56% of high stage cooling.

4. Locate the blower speed selection DIP switches on the integrated control module. Select the desired "cooling" speed tap by positioning switches 1 and 2 appropriately. Select the desired "adjust" tap by positioning switches 3 and 4 appropriately. Refer to the following figure for switch positions and their corresponding taps. Turn off power to furnace for a minimum of 10 seconds, allowing the motor to reset and recognize the new speed selection. Turn on power to furnace. Verify CFM by counting the number of times the green CFM LED blinks.

PRODUCT DESIGN

Cooling Speed Tap A	8 7 6 5 4 3 2 1 [][][][][][][][] O O F F F F	Normal*	8 7 6 5 4 3 2 1 [][][][][][][][] O O F F F F
Cooling Speed Tap B	8 7 6 5 4 3 2 1 [][][][][][][][] O O F N F F	+ (Plus) Adjust	8 7 6 5 4 3 2 1 [][][][][][][][] O O F N F F
Cooling Speed Tap C	8 7 6 5 4 3 2 1 [][][][][][][][] O O N F F F	- (Minus) Adjust	8 7 6 5 4 3 2 1 [][][][][][][][] O O N F F F
Cooling Speed Tap D*	8 7 6 5 4 3 2 1 [][][][][][][][] O O N N	Adjust Taps (* indicates factory setting)	
Cooling Speed Taps (* indicates factory setting)			
Heating Speed Tap A	8 7 6 5 4 3 2 1 [][][][][][][][] O O F F F F	Heating Speed Tap B*	8 7 6 5 4 3 2 1 [][][][][][][][] O O F N F F
Heating Speed Tap C	8 7 6 5 4 3 2 1 [][][][][][][][] O O N F F F	Heating Speed Tap D	8 7 6 5 4 3 2 1 [][][][][][][][] O O N N
Heating Speed Taps (* indicates factory setting)			

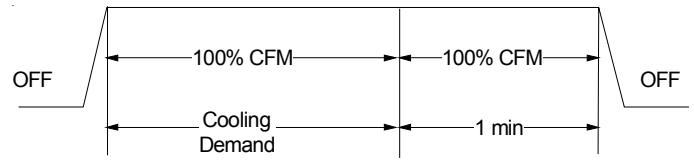

- Profile A provides only an OFF delay of one (1) minute at 100% of the cooling demand airflow.

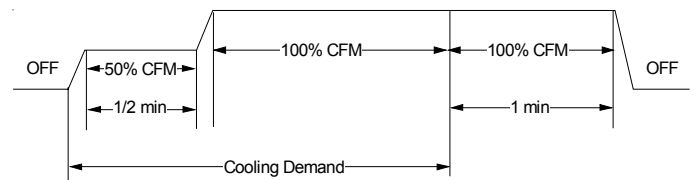

- Profile B ramps up to full cooling demand airflow by first stepping up to 50% of the full demand for 30 seconds. The motor then ramps to 100% of the required airflow. A one (1) minute OFF delay at 100% of the cooling airflow.

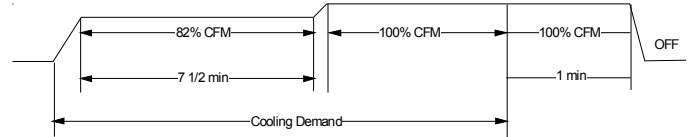

- Profile C ramps up to 82% of the full cooling demand airflow and operates there for approximately 7 1/2 minutes. The motor then steps up to the full demand airflow. Profile C also has a one (1) minute, 100% OFF delay.

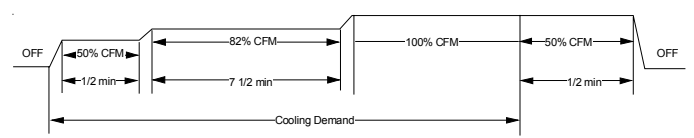

- The variable speed circulator blower also offers several custom ON/OFF ramping profiles. These profiles may be used to enhance cooling performance and increase control level. The ramping profiles are selected using DIP switches 5 and 6. Refer to the following figure for switch positions and their corresponding taps. Refer to the bullet points below for a description of each ramping profile. Turn OFF power to the furnace for a minimum of 10 seconds, allowing motor to reset and recognize the new profile selection. Turn ON power to the furnace. Verify profile selection by counting the green CFM LED blinks and timing each step of the ramping profile.
 - Profile A provides only an OFF delay of one (1) minute at 100% of the cooling demand airflow.

Ramping Profile Tap A*	8 7 6 5 4 3 2 1 [][][][][][][][] O O F F F F
Ramping Profile Tap B	8 7 6 5 4 3 2 1 [][][][][][][][] O O F N F F
Ramping Profile Tap C	8 7 6 5 4 3 2 1 [][][][][][][][] O O N F F F
Ramping Profile Tap D	8 7 6 5 4 3 2 1 [][][][][][][][] O O N N
Ramping Profiles (* indicates factory setting)	

PRODUCT DESIGN

6. Select the heating speed from the heating speed chart in the Product Data Book applicable to your model for your model. The adjust setting (already established by the cooling speed selection) determines which set of speeds are available. The selected speed must provide a temperature rise within the rise range listed with the particular model.

Example: The *MV90704CXA is set for 990 CFM on cooling, the "ADJUST" is set to "-" (minus). The four heating speeds available are "A Minus", "B Minus", "C Minus", and "D Minus". "A Minus" has a rise of 56°F for both stages which is within the 30-60°F rise range for the *MV90704CXA. This setting will keep electrical consumption to a minimum. Set the "Heat" speed DIP switches to "A".

7. Select the desired "heating" speed tap by positioning switches 7 and 8 appropriately. Refer to figure above. Turn off power to furnace for a minimum of 10 seconds, allowing motor to reset and recognize new speed selection. Turn on power to furnace. Verify selected CFM by counting the green CFM LED blinks.

In general lower heating speeds will: reduce electrical consumption, lower operating sound levels of the blower, and increase the outlet air temperature delivered to the home. The speeds available allow the blower performance to be optimized for the particular homeowner's needs.

CIRCULATOR BLOWER TIMINGS

80% & 90% Furnaces

NOTE: Items in this section refer to the air circulator blower fan, **NOT** to the induced draft blower. The induced draft blower timing sequence is not adjustable. The circulator blower fan timing is adjustable only on models with optional "heating fan OFF delay" adjustment pins or switches. **It is NOT** adjustable in any other circumstances.

As shipped, the circulator blower fan will remain on for 150 seconds after the gas valve closes. When a call for cooling occurs, the circulator fan comes on and remains on for 45 seconds after the call for cooling ends. During normal heating operation, the circulator fan will come on approximately 30 seconds after the gas valve opens.

Blower Heat Off Delay Timings

The integrated control module provides a selectable heat off delay function. The heat off delay period may be set to 90, 120, 150, 180 seconds using the DIP switches or jumper provided on the control module. The delay is factory shipped at 150 seconds but may be changed to suit the installation requirements and/or homeowner preference. Refer to the following figures for switch positions and corresponding delay times.

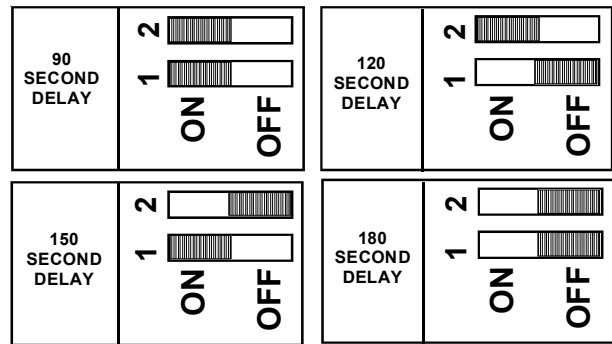

Single-Stage 80% and 90% Settings

ON		3	Heat Off Delay 90 Seconds
ON		2	
OFF		1	Heat Off Delay 120 Seconds
OFF		3	Heat Off * Delay 150 Seconds
OFF		2	
OFF		1	Heat Off Delay 180 Seconds
Heat Off Delay (* indicates factory setting)			

Two-Stage Variable Speed
80% and 90% Settings

PRODUCT DESIGN

CIRCULATING AIR AND FILTERS

DUCTWORK - AIR FLOW

Duct systems and register sizes must be properly designed for the C.F.M. and external static pressure rating of the furnace. Ductwork should be designed in accordance with the recommended methods of "Air Conditioning Contractors of America" manual D.

A duct system should be installed in accordance with Standards of the National Board of Fire Underwriters for the Installation of Air Conditioning, Warm Air Heating and Ventilating Systems, Pamphlets No. 90A and 90B.

A return air filter is not supplied with the furnace. The installer must supply a means of filtering all of the return air. Filter(s) shall comply with UL900 or CAN/ULC-S111 Standards. If the furnace is installed without filters, the warranty will be voided.

The following two charts show the bottom and side return filter sizes available for each size furnace. Larger sizes are also acceptable.

SIDE RETURN		
Cabinet Width (In.)	Nominal Filter Size (In.)	Approx. Flow Area (In.)
All	16x25x1	400

BOTTOM RETURN		
Cabinet Width (In.)	Nominal Filter Size (In.)	Approx. Flow Area (In.)
14"	14X25X1	350
17-1/2"	14X25X1	350
21"	16x25x1	400
24-1/2"	20X25X1	500

Refer to Minimum Filter Area tables to determine filter area requirement. **NOTE:** Filters can also be installed elsewhere in the duct system such as a central return.

AMV8, ADV8, AMH8, AMS8, ADS8, DDS8, DMS8, DHS8, GMS8, GDH8, GDS8, GHS8, GME8, GMH8, GMV8

MINIMUM FILTER SIZES

FURNACE INPUT	FILTER SIZE	TYPE
45M	160 in ²	permanent
68M	241 in ²	permanent
90M	320 in ²	permanent
115M	400 in ²	permanent
135M	370 in ²	permanent
45M	320 in ²	disposable
68M	483 in ²	disposable
90M	640 in ²	disposable
115M	800 in ²	disposable
135M	738 in ²	disposable

PERMANENT NOMINAL 600 F.M. FACE VELOCITY
DISPOSABLE NOMINAL 300 F.M. FACE VELOCITY

AMV9, ACV9, GMV9, GCV9, GMV95

		COOLING AIRFLOW REQUIREMENT (CFM)						
		600	800	1000	1200	1400	1600	2000
Input_Airflow	0453_XA	376*	384	480	576	---	---	---
	0703_XA	---	564*	564*	564*	672	---	---
	0704_XA	---	---	564*	564*	672	768	---
	0904_XA	---	---	752*	752*	752*	768	---
	0905_XA	---	---	---	752*	752*	768	800
	1155_XA	---	---	---	940*	940*	940*	800

*Minimum filter area dictated by heating airflow requirement.

Disposable Minimum Filter Area (in²)

[Based on a 300 ft/min filter face velocity]

		COOLING AIRFLOW REQUIREMENT (CFM)						
		600	800	1000	1200	1400	1600	2000
Input_Airflow	0453_XA	188*	192	240	288	---	---	---
	0703_XA	---	282*	282*	282*	336	---	---
	0704_XA	---	---	260*	260*	336	384	---
	0904_XA	---	---	376*	376*	376*	384	---
	0905_XA	---	---	---	376*	376*	384	480
	115_XA	---	---	---	470*	470*	470*	480

PRODUCT DESIGN

AMV9, ACV9, GMV9, GCV9, GMV95

		UPFLOW COOLING AIRFLOW REQUIREMENT (CFM)						
		600	800	1000	1200	1400	1600	2000
Input_Airflow	0453__XA	376*	384	480	576	---	---	---
	0704__XA	---	---	627*	627*	672	768	---
	0905__XA	---	---	---	836*	836*	836*	960
	1155__XA	---	---	---	940*	940*	940*	960

		COUNTERFLOW COOLING AIRFLOW REQUIREMENT (CFM)						
		600	800	1000	1200	1400	1600	2000
Input_Airflow	0704__XA	---	---	320*	320*	336	384	---
	0905__XA	---	---	---	427*	427*	427*	480

*Minimum filter area dictated by heating airflow requirement.

Permanent Minimum Filter Area (sq. in)

[Based on a 600 ft/min filter face velocity]
[Based on 300 ft/min filter face velocity]

Permanent Minimum Filter Area (in²)

[Based on 600 ft/min filter face velocity]

The sketch below shows how the filter is retained over the bottom return air opening on (Upflow) 90% furnace installations only with kit # RF000180.

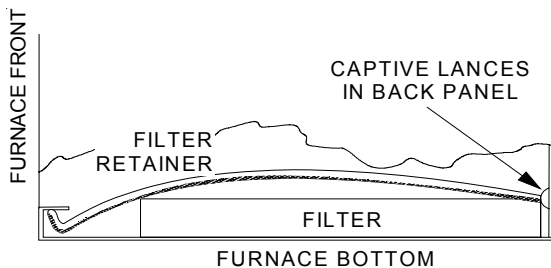

Optional (RF000180) Bottom Return Filter Retention

One inch throwaway filters should be sized for a face velocity of 300 feet per minute or less (14x25x1 throwaway = 730 CFM maximum, 16x25x1 throwaway = 830 CFM maximum, 18x25x1 throwaway = 940 CFM maximum, 20x25x1 throwaway = 1040 CFM maximum) All other filters should be sized according to their manufacturer's instructions.

To find the minimum filter requirement (in²) for either permanent or disposable filters divide the required airflow (CFM) by the rated velocity of the filter, either 300ft/min for disposable filter or 600ft/min for permanent filter. Multiply the number by 144 in.² to obtain the minimum filter requirement (in²).

EXAMPLE:

$$\text{Filter Size (in}^2\text{)} = \frac{1400 \text{ CFM} \times 144 \text{ in}^2}{600 \text{ ft./min. (Permanent)}}$$

$$\text{Filter Size (in}^2\text{)} = \frac{1400 \text{ CFM} \times 144 \text{ in}^2}{300 \text{ (Disposable) ft./min.}}$$

$$\text{Filter Size} = 672 \text{in}^2 \text{ Disposable}$$

$$\text{Filter Size} = 336 \text{in}^2 \text{ Permanent}$$

Upflow furnaces with air delivery of less than 1800 CFM:

Use one side return or one bottom return ductwork connection.

Upflow furnaces with air delivery of 1800 CFM or higher:

Use two side returns or one side return and one bottom return connection.

Guide dimples locate the side and bottom return cutout locations. Use a straight edge to scribe lines connecting the dimples. Cut out the opening on these lines. An undersized opening will cause reduced airflow. For bottom return connection, remove the bottom of the cabinet before setting the furnace on the raised platform or return air duct.

A closed return duct system must be used, with the return duct connected to the furnace. **NOTE: Ductwork must never be attached to the back of the furnace.** Supply and return connections to the furnace may be made with flexible joints to reduce noise transmission, if desired. If a central return is used, a connecting duct must be installed between the unit and the utility room wall so the blower will not interfere with combustion air or draft. The room, closet, or alcove must not be used as a return air chamber.

When the furnace is used in connection with a cooling unit, the furnace should be installed in parallel with or on the upstream side of the cooling unit to avoid condensation in the heating element. With a parallel flow arrangement, the dampers or other means used to control the flow of air must be adequate to prevent chilled air from entering the furnace and, if manually operated, must be equipped with means to prevent operation of either unit unless the damper is in the full heat or cool position.

When the furnace is heating, the temperature of the return air entering the furnace must be between **55°F** and **100°F**.

UPRIGHT FILTER INSTALLATIONS

Depending on the installation and/or customer preference, differing filter arrangements can be applied. Filters can be installed in the central return register, the bottom of the blower compartment (upflow filter kit # RF000180), a side panel external filter rack kit (upflow filter kit # EFR01), or the ductwork above a counterflow furnace (kit # RF000181).

PRODUCT DESIGN

As an alternative a media air filter or electronic air cleaner can be used as the requested filter. Refer to the following minimum filter requirement charts for determination of the minimum filter area to ensure proper unit performance. The following figures show possible filter locations. **NOTE:** A duct-work access door must be used in counterflow applications to allow filter removal. If the filter rack is used, the side of the plenum must be at least as tall as dimension "A" shown in the following illustration. For dimension of "A" refer to the following chart.

COUNTERFLOW FILTER INSTALLATION

This furnace has provisions for the installation of return air filters at the counterflow top return. The furnace will accommodate the following filter sizes depending on cabinet size:

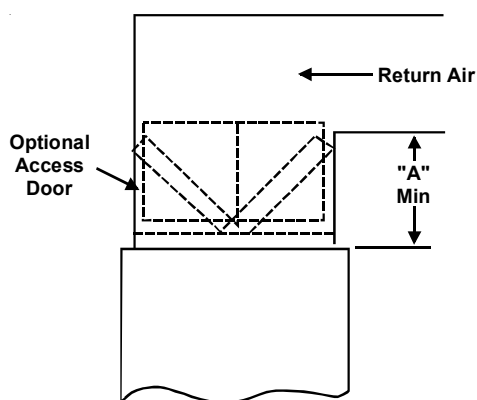

COUNTERFLOW TOP RETURN				
Cabinet Width	Filter Area (in ²)	Qty.	Filter Size (in)	Dimension "A": (in)
14	600	2	15x20x1	15.1
17 1/2				14.2
21				13.0
24 1/2				11.3
14	800	2	20x20x1	20.4
17 1/2				19.7
21				18.8
24 1/2				17.7
14	1000	2	25x20x1	25.5
17 1/2				25.0
21				24.3
24 1/2				23.4

Refer to Minimum Filter Area tables to determine filter area requirement. **NOTE:** Filters can also be installed elsewhere in the duct system such as a central return.

Horizontal Installations

Filter(s) must be installed external to the furnace casing for horizontal installations. For most installations it is preferable to use a central return with filters installed in the duct behind the return air grill. In this way filter replacement is relatively simple by merely removing the grille, rather than going into the attic or crawl space.

ADDITIONAL FILTERING ACCESSORIES

Internal Filter Retention Kit

These kits can be used only on 90% furnaces with either Up-flow installations kit (RF000180) or Down-flow kit (RF000181). These kits should not be used for Horizontal installations. See the accessories section of this manual for more information.

External Filter Rack Kit (EFR01)

The external filter rack kit is intended to provide a location external to the furnace casing, for installation of a permanent filter on upflow model furnaces. The rack is designed to mount over the indoor blower compartment area of either side panel, and provide filter retention as well as a location for attaching return air ductwork.

Electronic Air Cleaner (ASAS and GSAS) or Media Air Cleaner (AMU and GMU)

The electronic air cleaner and media air cleaner are multi-positional high efficiency air filtration devices that can be installed in any position, except with the access door facing down. The best location for the air cleaner is in the return air duct next to the blower compartment. Before installing the air cleaner, consider the application. The electronic air cleaner must be readily accessible for periodic inspection and cleaning of the pre-filters and electronic cells while the media air cleaner must be readily accessible for periodic inspection and replacement of the Media Air Cleaner (AMU and GMU) filter cartridge (3 per carton) M0-1056, M1-1056, M2-1056, M8-1056, to maintain maximum efficiency and trouble-free operation. Carbon Filters 1156-3 and 1856-3 (set of 3) are also available. See Product Catalog for exact filter for your model.

PRODUCT DESIGN

NORMAL SEQUENCE OF OPERATION

Goodman / Amana® Distinctions™ Brand Single-Stage 80% or 90% Furnaces

White-Rodgers 50A55 Integrated Ignition Control

POWER UP

1. 115 VAC power applied to furnace.
2. Integrated ignition control module performs internal checks.
3. Integrated ignition control module LED will light.
4. Integrated ignition control monitors safety circuits continuously.
5. Furnace awaits call from thermostat.

NORMAL HEATING SEQUENCE

1. R and W thermostat contacts close, initiating a call for heat.
2. Integrated control module performs safety circuit checks.
3. The induced draft blower is energized causing pressure switch contacts to close. Induced draft blower remains energized for pre-purge period. Humidifier terminals are energized with induced draft blower.
4. Ignitor warm up begins after pre-purge is completed. The White-Rodgers 50A55 ignition control has a variable ignitor warm up period between a *17-second maximum and a 5-second minimum*.
5. Gas valve opens at end of ignitor warm up period, delivering gas to burners to establish flame.
6. The control checks for a signal from the flame sensor within seven (4) seconds after the gas valve is energized. Gas will only continue to flow if a flame signal is present.
7. Circulator blower is energized on heat speed following a fixed thirty (30) second blower on delay. Electronic air cleaner terminals are energized with circulator blower.
8. Furnace runs, integrated control module monitors safety circuits continuously.
9. R and W thermostat contacts open, allowing the gas valve to cycle off.
10. Induced draft blower is de-energized following a fifteen (15) -second post purge. Humidifier terminals are de-energized.
11. Circulator blower is de-energized following a selectable heat off delay period (90, 120, 150 or 180 seconds). Electronic air cleaner terminals are de-energized.
12. Furnace awaits next call from thermostat.

The adjustable delay-off timing allows the installer to customize the comfort level.

Cooling Mode

The normal operational sequence in cooling mode is as follows:

1. R and Y thermostat contacts close, initiating a call for cool.
2. Integrated control module performs safety circuit checks.
3. Outdoor fan and compressor are energized.
4. Circulator blower is energized on cool speed following a fixed five (5) second on delay. Electronic air cleaner terminals are energized with circulator blower.
5. Furnace circulator blower and outdoor cooling unit run, integrated control module monitors safety circuits continuously.
6. R and Y thermostat contacts open, completing the call for cool.
7. Outdoor fan and compressor are de-energized.
8. Circulator blower is de-energized following a fixed forty five (45) second cool off delay period. Electronic air cleaner terminals are de-energized.
9. Furnace awaits next call from thermostat.

Fan Only Mode

The normal operational sequence in fan only mode is as follows:

1. R and G thermostat contacts close, initiating a call for fan.
2. Integrated control module performs safety circuit checks.
3. Circulator blower is energized on **heat speed**. Electronic air cleaner terminals are energized.
4. Circulator blower runs, integrated control module monitors safety circuits continuously.
5. R and G thermostat contacts open, completing the call for fan.
6. Circulator blower is de-energized. Electronic air cleaner terminals are de-energized.
7. Furnace awaits next call from thermostat.

PRODUCT DESIGN

NORMAL SEQUENCE OF OPERATION

Goodman Two-Stage 80% or 90% Furnaces White-Rodgers 50M56 Integrated Ignition Control

POWER UP

The normal power up sequence is as follows:

- 115 VAC power applied to furnace.
- Integrated control module performs internal checks.
- Integrated control module LED will light.
- Integrated control module monitors safety circuits continuously.
- Furnace awaits call from thermostat.

HEATING MODE

(MODE DIP SWITCH IS SET TO "1 STG" POSITION)

The normal operational sequence in heating mode is as follows:

- R and W thermostat contacts close, initiating a call for heat.
- Integrated control module performs safety circuit checks.
- Induced draft blower is energized for 15 second prepurge period causing pressure switch contacts to close.
- Igniter warm up begins after 15 second prepurge expires.
- Low and high stage gas valves open at end of igniter warm up period, delivering gas to burners and establishing flame.
- Integrated control module monitors flame presence. Gas valve will remain open only if flame is detected.
- Circulator blower is energized on high heat speed following a fixed thirty second blower on delay. Electronic air cleaner terminals are energized with circulator blower.
- Furnace operates; integrated control module monitors safety circuits continuously.
- R and W thermostat contacts open, completing the call for heat.
- Gas valve closes, extinguishing flame.
- Induced draft blower is de-energized following a fifteen second post purge.
- The circulator blower remains at high heat speed for thirty seconds. The circulator blower then switches to low heat speed for the remainder of the selected heat off delay period. For example, the selected heat off delay period is 150 seconds. The circulator blower operates at high heat for 30 seconds and at low speed for $150 - 30 = 120$ seconds.
- Furnace awaits the next call from thermostat.

(MODE DIP SWITCH IS SET TO "2 STG" POSITION)

The normal operational sequence in sequence is as follows:

- R and W thermostat contacts close, initiating a call for heat.
- Integrated control module performs safety circuit checks.
- Induced draft blower is energized for 15 second prepurge period causing pressure switch contacts to close.
- Igniter warm up begins after 15 second prepurge expires.
- Low and high-stage gas valves open at end of igniter warm up period, delivering gas to burners and establishing flame.
- High-stage gas valve closes after five seconds; low-stage gas valve remains open.
- Integrated control module monitors flame presence. Gas valve will remain open only if flame is detected.
- Circulator blower is energized on low heat speed following a fixed thirty second blower on delay. Electronic air cleaner terminals are energized with circulator blower.
- Furnace is now operating in low-stage heating mode.
- Furnace operates; integrated control module monitors safety circuits continuously.
- If low-stage delay period expires, control will shift operation from low-stage heating mode operation to high-stage heating mode operation. Control will energize circulator blower high heat speed and high stage gas valve.
- Furnace is now operating in high-stage heating mode.
- R and W thermostat contacts open, completing the call for heat.
- Induced draft blower is de-energized following a fifteen second post purge.
- Circulator blower is de-energized following a heat off delay period (selectable 100 or 150 seconds; factory set at 150 seconds).
If the furnace is operating in the low-stage heating mode when thermostat contacts open, circulator remains at low heat speed for the selected delay off period.
If the furnace is operating in high-stage heating mode when the thermostat contacts open, the circulator blower remains at high heat speed for thirty seconds. The circulator blower then switches to low heat speed for the remainder of the selected heat off delay period. For example, the selected heat off delay period is 150 seconds. The circulator blower operates at high heat for 30 seconds and at low speed for $150 - 30 = 120$ seconds.
- Furnace awaits the next call from thermostat.

PRODUCT DESIGN

COOLING MODE

The normal operational sequence in cooling mode is as follows:

- R and Y thermostat contacts close, initiating a call for cool.
- Integrated control module performs safety circuit checks.
- Outdoor fan and compressor are energized.
- Circulator blower is energized on cool speed following a fixed five second on delay. Electronic air cleaner terminals are energized with circulator blower.
- Furnace circulator blower and outdoor cooling unit run, integrated control module monitors safety circuits continuously.
- R and Y thermostat contacts open, completing the call for cool.
- Outdoor fan and compressor are de-energized.
- Circulator blower is de-energized following a fixed forty five second cool off delay period. Electronic air cleaner terminals are de-energized.
- Furnace awaits the next call from thermostat.

FAN ONLY MODE

The normal operational sequence in fan only mode is as follows:

- R and G thermostat contacts close, initiating a call for fan.
- Integrated control module performs safety circuit checks.
- Circulator blower is energized on low heat speed. Electronic air cleaner terminals are energized.
- Circulator blower runs, integrated control module monitors safety circuits continuously.
- R and G thermostat contacts open, completing the call for fan.
- Circulator blower is de-energized. Electronic air cleaner terminals are de-energized.
- Furnace awaits the next call from thermostat.

PRODUCT DESIGN

NORMAL SEQUENCE OF OPERATION

Goodman Two-Stage 80% or 90% Furnaces White-Rodgers 50V51 Integrated Ignition Control

POWER UP

The normal power up sequence is as follows:

1. 115 VAC power applied to furnace.
2. Integrated control module performs internal checks.
3. Integrated control module LED will light.
4. Integrated control module monitors safety circuits continuously.
5. Furnace awaits call from thermostat.

HEATING MODE

The normal operational sequence in heating mode is as follows:

1. R and W1 (or R and W1/W2) thermostat contacts close, initiating a call for heat.
2. Integrated control module performs safety circuit checks.
3. Induced draft blower is energized on high speed for a 15-second prepurge. Humidifier terminals are energized with induced draft blower.
4. Induced draft blower steps to low speed following prepurge. Low stage pressure switch contacts are closed.
5. Igniter warm up begins upon step to low speed and presence of closed low stage pressure switch contacts.
6. Gas valve opens at end of igniter warm up period, delivering gas to burners and establishing flame.
7. Integrated control module monitors flame presence. Gas valve will remain open only if flame is detected.
8. If the thermostat call is for low heat, gas valve and induced draft blower will continue on low stage. If the call is for high heat, the gas valve and induced draft blower will change to high stage.
9. Circulator blower is energized on heat speed following a fixed thirty (30) second blower on delay. The circulator blower requires thirty (30) seconds to ramp up to full speed. Electronic air cleaner terminals are energized with circulator blower.
10. Furnace is now operating on the specified stage called for by the two-stage thermostat.
11. Furnace runs, integrated control module monitors safety circuits continuously.
12. If the two-stage thermostat changes the call from low heat to high heat, the integrated control module will immediately switch the induced draft blower, gas valve, and circulator blower to their high stage settings.
13. If the two-stage thermostat changes the call from high heat to low heat, the control will immediately switch the induced draft blower and gas valve to their low stage settings. The circulator blower will remain on high heating speed for thirty (30) seconds before switching to the low heat circulating speed.

14. R and W1 (or R and W1/W2) thermostat contacts open, allowing the gas valve to cycle off.
15. Induced draft blower is de-energized following a fifteen (15) second post purge. Humidifier terminals are de-energized.
16. Circulator blower continues running for the selected heat off delay period (90, 120, 150 or 180 seconds). The speed run during this period depends on the last heat call provided by the thermostat.

If the last call for heat was a call for low heat, the air circulator motor will run on low heat speed for the duration of the heat off delay period (90, 120, 150 or 180 seconds).

If the last call for heat was a call for high heat, the air circulating motor will run on the high heating speed for thirty (30) seconds and then switch to the low heating speed for the **balance** of the heat off delay period (60, 90, 120 or 150 seconds).
17. Circulator blower and electronic air cleaner terminals are de-energized.
18. Circulator blower ramps down to OFF during the 30 seconds following the heat off delay period.
19. Furnace awaits next call from thermostat.

COOLING MODE

The normal operational sequence in cooling mode is as follows:

1. R and YLO/G or Y/G thermostat contacts close, initiating a call for cool.
2. Integrated control module performs safety circuit checks.
3. Outdoor fan and compressor are energized to their appropriate speed.
4. Circulator blower is energized on the appropriate cool speed at the level and time determined by the selected ramping profile. Electronic air cleaner terminals are energized with circulator blower.
5. Furnace circulator blower and outdoor cooling unit run their appropriate speed, integrated control module monitors safety circuits continuously.
6. R and YLO/G or Y/G thermostat contacts open, completing the call for cool.
7. Outdoor fan and compressor are de-energized.
8. Circulator blower continues running during a cool off delay period. The OFF delay time and airflow level are determined by the selected ramping profile.
9. Electronic air cleaner terminals and circulator blower are de-energized.
10. Furnace awaits next call from thermostat.

PRODUCT DESIGN

FAN ONLY MODE

The normal operational sequence in fan only mode is as follows:

1. R and G thermostat contacts close, initiating a call for fan.
2. Integrated control module performs safety circuit checks.
3. Circulator blower is energized on continuous fan speed (56% of high stage cooling) following a five (5) second delay. Electronic air cleaner terminals are energized.
4. Circulator blower runs, integrated control module monitors safety circuits continuously.
5. R and G thermostat contacts open, completing the call for fan.
6. Circulator blower is de-energized. Electronic air cleaner terminals are de-energized.
7. Furnace awaits next call from thermostat.

DEHUMIDIFICATION MODE

The normal operational sequence in dehumidification mode is as follows:

1. R and YLO/G or Y/G thermostat contacts close, initiating a call for cool.
2. Integrated control module performs safety circuit checks.
3. Outdoor fan and compressor are energized to their appropriate speed.
4. Circulator blower is energized on the appropriate cool speed at the level and time determined by the selected ramping profile. Electronic air cleaner terminals are energized with circulator blower.
5. Furnace circulator blower and outdoor cooling unit run their appropriate speed, integrated control module monitors safety circuits continuously.
6. Dehumidistat opens on humidity rise allowing the furnace circulator blower to operate at 80% of the cooling speed during combined thermostat call for cooling and dehumidistat call for dehumidification.
7. Humidistat opens on humidity fall allowing furnace circulator blower to switch back to normal cooling speed.
8. R and YLO/G or Y/G thermostat contacts open, completing the call for cool.
9. Outdoor fan and compressor are de-energized.
10. Circulator blower continues running during a cool off delay period. The OFF delay time and airflow level are determined by the selected ramping profile.
11. Electronic air cleaner terminals and circulator blower are de-energized.
12. Furnace awaits next call from thermostat.

PRODUCT DESIGN

NORMAL SEQUENCE OF OPERATION

Amana® Brand Single-Stage

80% or 90% Furnaces

White-Rodgers 50A65 Integrated Ignition Control

POWER UP

1. 115 VAC power applied to furnace.
2. Integrated ignition control performs internal checks.
3. Integrated ignition control module LED will light.
4. Integrated ignition control monitors safety circuits continuously.
5. Furnace awaits call from thermostat.

NORMAL HEATING SEQUENCE

1. Thermostat calls for heat .
2. The induced draft blower is energized for pre-purge period.
3. The igniter is energized following pre-purge and is allowed to preheat.
4. The gas valve is energized delivering gas to the burners and starting combustion.
5. The control checks for a signal from the flame sensor within seven (4) seconds after the gas valve is energized. Gas will only continue to flow if a signal is present.
6. Circulator blower is energized on heat speed following a fixed thirty second blower on delay. Electronic air cleaner terminals are energized with circulator blower.
7. Furnace runs, integrated control module monitors safety circuits continuously.
9. R and W thermostat contacts open, allowing the gas valve to cycle off.
10. Induced draft blower is de-energized following a fifteen (15) -second post purge. Humidifier terminals are de-energized.
11. Circulator blower is de-energized following a selectable heat off delay period (90, 120, 150 or 180 seconds). Electronic air cleaner terminals are de-energized.

The adjustable delay-off timing allows the installer to customize the comfort level.

COOLING MODE

The normal operational sequence in cooling mode is as follows:

1. R and Y thermostat contacts close, initiating a call for cool.
2. Integrated control module performs safety circuit checks.
3. Outdoor fan and compressor are energized.
4. Circulator blower is energized on cool speed following a fixed five second on delay. Electronic air cleaner terminals are energized with circulator blower.
5. Furnace circulator blower and outdoor cooling unit run, integrated control module monitors safety circuits continuously.
6. R and Y thermostat contacts open, completing the call for cool.
7. Outdoor fan and compressor are de-energized.
8. Circulator blower is de-energized following a fixed forty five second cool off delay period. Electronic air cleaner terminals are de-energized.
9. Furnace awaits next call from thermostat.

FAN ONLY MODE

The normal operational sequence in fan only mode is as follows:

1. R and G thermostat contacts close, initiating a call for fan.
2. Integrated control module performs safety circuit checks.
3. Circulator blower is energized on **heat speed**. Electronic air cleaner terminals are energized.
4. Circulator blower runs, integrated control module monitors safety circuits continuously.
5. R and G thermostat contacts open, completing the call for fan.
6. Circulator blower is de-energized. Electronic air cleaner terminals are de-energized.
7. Furnace awaits next call from thermostat.

PRODUCT DESIGN

NORMAL SEQUENCE OF OPERATION

Amana® Brand Two-Stage 80% and 90% Furnaces White-Rodgers 50V61 Integrated Ignition Control

POWER UP

The normal power up sequence is as follows:

1. 115 VAC power applied to furnace.
2. Integrated control module performs internal checks.
3. Integrated control module LED will light.
4. Integrated control module monitors safety circuits continuously.
5. Furnace awaits call from thermostat.

HEATING MODE

The normal operational sequence in heating mode is as follows:

1. R and W1 (or R and W1/W2) thermostat contacts close, initiating a call for heat.
2. Integrated control module performs safety circuit checks.
3. Induced draft blower is energized on high speed for a 15-second prepurge. Humidifier terminals are energized with induced draft blower.
4. Induced draft blower steps to low speed following prepurge. Low stage pressure switch contacts are closed.
5. Igniter warm up begins upon step to low speed and presence of closed low stage pressure switch contacts.
6. Gas valve opens at end of igniter warm up period, delivering gas to burners and establishing flame.
7. Integrated control module monitors flame presence. Gas valve will remain open only if flame is detected.
8. If the thermostat call is for low heat, gas valve and induced draft blower will continue on low stage. If the call is for high heat, the gas valve and induced draft blower will change to high stage.
9. Circulator blower is energized on heat speed following a fixed thirty (30) second blower on delay. The circulator blower requires thirty (30) seconds to ramp up to full speed. Electronic air cleaner terminals are energized with circulator blower.

10. Furnace is now operating on the specified stage called for by the two-stage thermostat.
11. Furnace runs, integrated control module monitors safety circuits continuously.
12. If the two-stage thermostat changes the call from low heat to high heat, the integrated control module will immediately switch the induced draft blower, gas valve, and circulator blower to their high stage settings.
13. If the two-stage thermostat changes the call from high heat to low heat, the control will immediately switch the induced draft blower and gas valve to their low stage settings. The circulator blower will remain on high heating speed for thirty (30) seconds before switching to the low heat circulating speed.
14. R and W1 (or R and W1/W2) thermostat contacts open, allowing the gas valve to cycle off.
15. Induced draft blower is de-energized following a fifteen (15) second post purge. Humidifier terminals are de-energized.
16. Circulator blower continues running for the selected heat off delay period (90, 120, 150 or 180 seconds). The speed run during this period depends on the last heat call provided by the thermostat.

If the last call for heat was a call for low heat, the air circulator motor will run on low heat speed for the duration of the heat off delay period (90, 120, 150 or 180 seconds).

If the last call for heat was a call for high heat, the air circulating motor will run on the high heating speed for thirty (30) seconds
17. Circulator blower and electronic air cleaner terminals are de-energized.
18. Circulator blower ramps down to OFF during the 30 seconds following the heat off delay period.
19. Furnace awaits next call from thermostat.

PRODUCT DESIGN

COOLING MODE

The normal operational sequence in cooling mode is as follows:

1. R and YLO/G or Y/G thermostat contacts close, initiating a call for cool.
2. Integrated control module performs safety circuit checks.
3. Outdoor fan and compressor are energized to their appropriate speed.
4. Circulator blower is energized on the appropriate cool speed at the level and time determined by the selected ramping profile. Electronic air cleaner terminals are energized with circulator blower.
5. Furnace circulator blower and outdoor cooling unit run their appropriate speed, integrated control module monitors safety circuits continuously.
6. R and YLO/G or Y/G thermostat contacts open, completing the call for cool.
7. Outdoor fan and compressor are de-energized.
8. Circulator blower continues running during a cool off delay period. The OFF delay time and airflow level are determined by the selected ramping profile.
9. Electronic air cleaner terminals and circulator blower are de-energized.
10. Furnace awaits next call from thermostat.

FAN ONLY MODE

The normal operational sequence in fan only mode is as follows:

1. R and G thermostat contacts close, initiating a call for fan.
2. Integrated control module performs safety circuit checks.
3. Circulator blower is energized on continuous fan speed (56% of high stage cooling) following a five (5) second delay. Electronic air cleaner terminals are energized.
4. Circulator blower runs, integrated control module monitors safety circuits continuously.
5. R and G thermostat contacts open, completing the call for fan.
6. Circulator blower is de-energized. Electronic air cleaner terminals are de-energized.
7. Furnace awaits next call from thermostat.

DEHUMIDIFICATION MODE

The normal operational sequence in dehumidification mode is as follows:

1. R and YLO/G or Y/G thermostat contacts close, initiating a call for cool.
2. Integrated control module performs safety circuit checks.
3. Outdoor fan and compressor are energized to their appropriate speed.
4. Circulator blower is energized on the appropriate cool speed at the level and time determined by the selected ramping profile. Electronic air cleaner terminals are energized with circulator blower.
5. Furnace circulator blower and outdoor cooling unit run their appropriate speed, integrated control module monitors safety circuits continuously.
6. Dehumidistat opens on humidity rise allowing the furnace circulator blower to operate at 80% of the cooling speed during combined thermostat call for cooling and dehumidistat call for dehumidification.
7. Humidistat opens on humidity fall allowing furnace circulator blower to switch back to normal cooling speed.
8. R and YLO/G or Y/G thermostat contacts open, completing the call for cool.
9. Outdoor fan and compressor are de-energized.
10. Circulator blower continues running during a cool off delay period. The OFF delay time and airflow level are determined by the selected ramping profile.
11. Electronic air cleaner terminals and circulator blower are de-energized.
12. Furnace awaits next call from thermostat.

SYSTEM OPERATION

HEATING - Abnormal Operation

(Amana® Brand 80% and 90% Single Stage Furnaces - White Rodgers 50A65 Ignition Control)

The following presents the probable causes of questionable furnace operation and how to fix them. Look through the observation window in the blower access door and make a note of the number of flashes in sequence between pauses. Next, refer to the *Troubleshooting Chart* on the following pages for an interpretation of the LED signals and to the information in this section for a description of the problem.

1. **Internal Control Failure with Integrated Ignition Control.** Check for voltage to the furnace and low voltage at the control board. Check for blown fuse on the control board. If the control determines it has an internal fault, it enters a locked-out state. Any of the situations mentioned will cause the diagnostic LED to provide **no signal**. The control board should only be replaced only after all other checks from the *Troubleshooting Chart* have been verified.
2. **System Lockout.** If a flame is not sensed during the first seven (4) seconds after the gas valve is energized, the control turns off the gas. There will then be a 30 second delay while the induced draft blower is energized to purge the heat exchanger. The ignitor will next be energized and preheated for 20 seconds. The gas valve will then be energized. If flame is not sensed in seven (4) seconds the gas valve will be de-energized and another purge will occur. The control will cycle the gas valve a total of three (3) times before it determines it cannot establish measurable combustion and enters a locked out state. The diagnostic light code for this problem is **one short flash** followed by a longer pause. The control can be reset and brought out of lockout mode by turning the thermostat off for more than 5 seconds and less than 20 seconds and then back on. It can also be reset by turning off the electrical disconnect switch to the furnace for a minimum of 5 seconds.

NOTE: The control board will automatically reset one hour after lockout occurs. If the furnace frequently has to be reset, it means that a problem exists that should be corrected. Refer to *Troubleshooting Chart* on the following pages for aid in determining the cause.

3. **Pressure Switch Stuck Closed.** If the control senses the pressure switch is closed when the induced draft blower is off, it waits until the fault is corrected. The diagnostic light code for this problem is **two short flashes** followed by a longer pause. The probable cause is either a faulty pressure switch or wiring.

4. **Pressure Switch Stuck Open.** If, after the induced draft blower is energized, the pressure switch does not close, within 5 minutes, the control will go into a 1-hour lockout. The control will automatically reset from lockout and restart the ignition sequence. The diagnostic light code for this problem is **three short flashes** followed by a pause.

The probable causes are either disconnected hose to the pressure switch, faulty pressure switch or wiring, restricted air intake or flue piping.

5. **Open Primary or Auxiliary Limit.** If the limit control opens, the air circulator blower will be turned on until the limit closes. The induced draft blower will turn off for 5 seconds then turn off. The diagnostic light code for this problem is **four short flashes** followed by a pause. The probable cause is either low conditioned air flow due to dirty filter or resistance in duct work, faulty limit, faulty blower, or blower speed set to low.
6. **Flame Sensed with No Call for Heat.** If the control senses a flame when the gas valve is de-energized, it will run the air circulation blower and the induced draft blower continuously with no further furnace operation. The diagnostic flash code for this is **five flashes**. The probable causes are either a short to ground in flame sense circuit, miswiring, lingering burner flame or a slow closing gas valve.
7. **Open Rollout Limit.** If the rollout control opens, the air circulator blower will be energized all the time. The diagnostic light code for this problem is **six flashes** followed by a pause. The probable cause is either restricted flue piping or improper air requirements.
8. **Low Flame Sense Signal.** If the furnace continues to operate and the micro-amp signal from the flame sensor falls below specified level, the diagnostic light code for this problem will be **seven flashes** followed by a pause. The probable cause is either a coated/oxidized sensor, incorrectly positioned sensor in burner flame or lazy burner flame due to improper gas pressure or combustion air.
9. **Igniter circuit or poor ground (AMS8, AMS9, ADS8, ACS9).** Improperly connected igniter, bad igniter or poor ground to the equipment. The diagnostic light code for this problem is **eight flashes**.
10. **Reversed Polarity.** If the 115V or 24V AC power leads are reversed, the furnace will fail to operate. The diagnostic light code for this problem is **continuously flashing**. The probable cause is either the 115V AC power to furnace or integrated control module is reversed, the 24V AC wires to transformer are reversed, or poor unit ground.

SYSTEM OPERATION

HEATING - Abnormal Operation

(Amana® Brand 80% & 90% Variable Speed Furnaces - White Rodgers 50V61 Ignition Control)

The following presents the probable causes of questionable furnace operation and how to fix them. Look through the observation window in the blower access door and make a note of the number of flashes in sequence between pauses. Next, refer to the *Troubleshooting Chart* on the following pages for an interpretation of the LED signals and to the information in this section for a description of the problem.

1. **Internal Control Failure with Integrated Ignition Control.** Check for voltage to the furnace and low voltage at the control board. Check for blown fuse on the control board. If the control determines it has an internal fault, it enters a locked-out state. Any of the situations mentioned will cause the diagnostic LED to provide **no signal**. The control board should only be replaced only after all other checks from the *Troubleshooting Chart* have been verified.
2. **System Lockout.** If a flame is not sensed during the first seven (4) seconds after the gas valve is energized, the control turns off the gas. There will then be a 30 second delay while the induced draft blower is energized to purge the heat exchanger. The ignitor will again be energized and preheated for (20) seconds. The gas valve will then be energized. If flame is not sensed the gas valve will be de-energized and another purge will occur and a third ignitor warm up for (20) seconds will occur. The control will cycle the gas valve a total of three (3) times before it determines it cannot establish measurable combustion and enters a locked out state. The diagnostic light code for this problem is **one short flash** followed by a longer pause. The control can be reset and brought out of lockout mode by turning the thermostat off for more than 5 seconds and less than (20) seconds and then back on. It can also be reset by turning off the electrical disconnect switch to the furnace for a minimum of (5) seconds.

NOTE: The control board will automatically reset one hour after lockout occurs. If the furnace frequently has to be reset, it means that a problem exists that should be corrected. Refer to *Troubleshooting Chart* on the following pages for aid in determining the cause.

3. **Low Stage Pressure Switch Stuck Closed.** If the control senses the low stage pressure switch is closed when the induced draft blower is off, it waits until the fault is corrected. The diagnostic light code for this problem is **two short flashes** followed by a longer pause. The probable cause is either a faulty pressure switch or wiring.

4. **Pressure Switch Stuck Open.** If, after the induced draft blower is energized, the pressure switch does not close within 5 minutes, the control will go into a 1-hour lock-out. The control will automatically reset from lockout and restart the ignition sequence. The diagnostic light code for this problem is **three short flashes** followed by a pause.

The probable causes are either disconnected hose to the pressure switch, faulty pressure switch or wiring, restricted air intake or flue piping.

5. **Open Primary or Auxiliary Limit.** If the limit control opens, the air circulator blower will be turned on until the limit closes. The induced draft blower will turn on for (15) seconds, then turn off. The diagnostic light code for this problem is **four short flashes** followed by a pause. The probable cause is either low conditioned air flow due to dirty filter or resistance in duct work, faulty limit, faulty blower, or blower speed set to low.
6. **Flame Sensed with No Call for Heat.** If the control senses a flame when the gas valve is de-energized, it will run the air circulation blower and the induced draft blower continuously with no further furnace operation. The diagnostic flash code for this is a **five flashes**. The probable causes are either a short to ground in flame sense circuit, miswiring, lingering burner flame or a slow closing gas valve.
7. **Low Flame Sense Signal.** If the furnace continues to operate and the micro-amp signal from the flame sensor falls below specified level, the diagnostic light code for this problem will be **seven flashes** followed by a pause. The probable cause is either a coated/oxidized sensor, incorrectly positioned sensor in burner flame or lazy burner flame due to improper gas pressure or combustion air.
8. **Reversed Polarity.** If the 115V or 24V AC power leads are reversed, the furnace will fail to operate. The diagnostic light code for this problem is **continuously flashing**. The probable cause is either the 115V AC power to furnace or integrated control module is reversed, the 24V AC wires to transformer are reversed, or poor unit ground.
9. **Check Igniter or No Ground Condition.** Check for broken or improperly connected igniter. Check for proper ground and correct. The diagnostic light code for this problem is **eight flashes** followed by a pause.
10. **High Stage Pressure Switch Stuck Open.** This condition can occur if the pressure switch hose is blocked or pinched. Check for blocked flue and/or inlet air pipe. Blocked drain, weak induced draft blower and malfunctioning pressure switch are possible. The diagnostic light code for this problem is **nine flashes** followed by a pause.

SYSTEM OPERATION

HEATING - Abnormal Operation

(Goodman / Amana® Distinctions™ Brand 80% Furnaces - White Rodgers 50A55 Ignition Control)

The following presents the probable causes of questionable furnace operation and how to fix them. Look through the observation window in the blower access door and make a note of the number of flashes in sequence between pauses. Next, refer to the *Troubleshooting Chart* on the following pages for an interpretation of the LED signals and to the information in this section for a description of the problem.

1. **Internal Control Failure with Integrated Ignition Control.** Check for voltage to the furnace and low voltage at the control board. Check for blown fuse on the control board. If the control determines it has an internal fault, it enters a locked-out state. Any of the situations mentioned will cause the diagnostic LED to provide **no signal**. The control board should only be replaced after all other checks from the *Troubleshooting Chart* have been verified.
2. **System Lockout.** If a flame is not sensed during the first seven (4) seconds after the gas valve is energized, the control turns off the gas. There will then be a 30 second delay while the induced draft blower is energized to purge the heat exchanger. The ignitor will next be energized and preheated for (8) seconds. The gas valve will then be energized. If flame is not sensed in seven (4) seconds the gas valve will be de-energized and another purge will occur. The control will cycle the gas valve a total of three (3) times before it determines it cannot establish measurable combustion and enters a locked out state. The diagnostic light code for this problem is **one short flash** followed by a longer pause. The control can be reset and brought out of lockout mode by turning the thermostat off for more than (5) seconds and less than (20) seconds and then back on. It can also be reset by turning off the electrical disconnect switch to the furnace for a minimum of 5 seconds.

NOTE: The control board will automatically reset one hour after lockout occurs. If the furnace frequently has to be reset, it means that a problem exists that should be corrected. Refer to *Troubleshooting Chart* on the following pages for aid in determining the cause.

3. **Pressure Switch Stuck Closed.** If the control senses the pressure switch is closed when the induced draft blower is off, it waits until the fault is corrected. The diagnostic light code for this problem is **two short flashes** followed by a longer pause. The probable cause is either a faulty pressure switch or wiring.

4. **Pressure Switch Stuck Open.** If, after the induced draft blower is energized, the pressure switch does not close within 5 minutes, the control will go into a 1-hour lock-out. The control will automatically reset from lockout and restart the ignition sequence. The diagnostic light code for this problem is **three short flashes** followed by a pause. The probable causes are either disconnected hose to the pressure switch, faulty pressure switch or wiring, or restricted air intake or flue piping.
5. **Open Primary or Auxiliary Limit.** If the limit control opens, the air circulator blower will be turned on until the limit closes. The induced draft blower will turn off for 5 seconds then turn off. The diagnostic light code for this problem is **four short flashes** followed by a pause. The probable cause is either low conditioned air flow due to dirty filter or resistance in duct work, faulty limit, faulty blower, or blower speed set to low.
6. **Flame Sensed with No Call for Heat.** If the control senses a flame when the gas valve is de-energized, it will run the air circulation blower and the induced draft blower continuously with no further furnace operation. The diagnostic flash code for this is a **five flashes**. The probable causes are either a short to ground in flame sense circuit, miswiring, lingering burner flame or a slow closing gas valve.
7. **Open Rollout Limit.** If the rollout control opens, the air circulator blower will be energized all the time. The diagnostic light code for this problem is **six flashes** followed by a pause. The probable cause is either restricted flue piping or improper air requirements.
8. **Low Flame Sense Signal.** If the furnace continues to operate and the micro-amp signal from the flame sensor falls below specified level, the diagnostic light code for this problem will be **seven flashes** followed by a pause. The probable cause is either a coated/oxidized sensor, incorrectly positioned sensor in burner flame or lazy burner flame due to improper gas pressure or combustion air.
9. **Igniter circuit or poor ground (AMS8, AMS9, ADS8, ACS9).** Improperly connected igniter, bad igniter or poor ground to the equipment. The diagnostic light code for this problem is **eight flashes**.

SYSTEM OPERATION

NORMAL SEQUENCE OF OPERATION

Goodman 2-Stage Variable Speed

Integrated Ignition Control

Refer to Timing Charts for sequencing.

The normal power up sequence is as follows:

- 115 VAC power applied to furnace.
- Integrated control module performs internal checks.
- Integrated control module flashes LED lights.
- Integrated control module monitors safety circuits continuously.
- Furnace awaits call from thermostat.

NORMAL HEATING SEQUENCE

- R and W1 (or R and W1/W2) thermostat contacts close, initiating a call for heat.
- Integrated control module performs safety circuit checks.
- Induced draft blower is energized on high speed for a 15-second prepurge. Humidifier terminals are energized with induced draft blower.
- Induced draft blower steps to low speed following prepurge. Low stage pressure switch contacts are closed.
- Igniter warm up begins upon step to low speed and presence of closed low stage pressure switch contacts.
- Gas valve opens at end of igniter warm up period, delivering gas to burners and establishing flame.
- Integrated control module monitors flame presence. Gas valve will remain open only if flame is sensed.
- If the thermostat call is for low heat, gas valve and induced draft blower will continue on low stage. If the call is for high heat, the gas valve and induced draft blower will change to high stage.
- Circulator blower is energized on the appropriate heat speed following a fixed thirty second blower on delay. The circulator blower requires 30 seconds to ramp up to full speed. Electronic air cleaner terminals are energized with circulator blower.
- Furnace is now operating on the specified stage called for by the two-stage thermostat.
- Furnace runs, integrated control module monitors safety circuits continuously.
- If the two-stage thermostat changes the call from low heat to high heat, the integrated control module will immediately switch the induced draft blower, gas valve, and circulator blower to their high stage settings.
- If the two-stage thermostat changes the call from high heat to low heat, the control will immediately switch the induced draft blower and gas valve to their low stage settings. The circulator blower will remain on high heating speed for thirty seconds before switching to the low heat circulating speed.
- R and W1 (or R and W1/W2) thermostat contacts open, completing the call for heat.

- Gas valve closes, extinguishing flame.
- Induced draft blower is de-energized following a fifteen second post purge. Humidifier terminals are de-energized.
- Circulator blower continues running for the selected heat off delay period (90, 120, 150 or 180 seconds). The speed run during this period depends on the last heat call provided by the thermostat.
If the last call for heat was a call for high heat, the air circulating motor will run on the high heating speed for thirty seconds and then switch to the low heating speed for the **balance** of the heat off delay period
- Electronic air cleaner terminals is de-energized
- Circulator blower ramps down to OFF during the 30 seconds following the heat off delay period.
- Furnace awaits next call from thermostat.

NORMAL COOLING SEQUENCE - INTEGRATED IGNITION CONTROL

- R and YLO/G or Y/G thermostat contacts close, initiating a call for cool.
- Integrated control module performs safety circuit checks.
- Outdoor fan and compressor are energized to their appropriate speed.
- Circulator blower is energized on the appropriate cool speed following a fixed five second on delay. The circulator blower requires 30 seconds to ramp up to full speed. Electronic air cleaner terminals are energized with circulator blower.
- Furnace circulator blower and outdoor cooling unit run their appropriate speed, integrated control module monitors safety circuits continuously.
- R and YLO/G or Y/G thermostat contacts open, completing the call for cool.
- Outdoor fan and compressor are de-energized.
- Circulator blower continues running for a cool off delay period. The OFF delay time and airflow level are determined by the selected ramping profile.
- Electronic air cleaner terminals and circulator blower are de-energized.
- Furnace awaits next call from thermostat.

SYSTEM OPERATION

CONSTANT FAN

- R and G thermostat contacts close, initiating a call for fan.
- Integrated control module performs safety circuit checks.
- Circulator blower is energized on continuous fan speed (56% of high stage cooling) following a five (5) second delay. Electronic air cleaner terminals are energized.
- Circulator blower runs, integrated control module monitors safety circuits continuously.
- R and G thermostat contacts open, completing the call for fan.
- Circulator blower is de-energized. Electronic air cleaner terminals are de-energized.
- Furnace awaits next call from thermostat.

START-UP PROCEDURE AND ADJUSTMENT

Furnace must have a 115 VAC power supply properly connected and grounded. Proper polarity must be maintained for correct operation. An interlock switch prevents furnace operation if the blower door is not in place. Keep the blower access door in place except for inspection and maintenance.

This furnace is also equipped with a self-diagnosing electronic control module. In the event a furnace component is not operating properly, the control module LED will flash on and off in a factory-programmed sequence, depending on the problem encountered. This light can be viewed through the observation window in the blower access door. Refer to the *Troubleshooting Chart* for further explanation of the lighting codes.

Follow the start-up and adjustment items, refer to further information in *Section XIII, Operational Checks*.

FURNACE OPERATION

Purge gas lines of air prior to start-up. Do not purge lines into an enclosed burner compartment.

Check for leaks using an approved chloride-free soap and water solution, an electronic combustible gas detector, or other approved method. Verify that all required kits (propane gas, high altitude, etc.) have been appropriately installed.

NOTE: An interlock switch prevents furnace operation if the blower door is not in place. Keep the blower access doors in place except for inspection and maintenance.

FURNACE START-UP

1. Close the manual gas shutoff valve external to the furnace.
2. Turn off the electrical power to the furnace.
3. Set the room thermostat to the lowest possible setting.
4. Remove the burner compartment door.

NOTE: This furnace is equipped with an ignition device which automatically lights the burner. Do not try to light the burner by hand.

5. Move the furnace gas valve manual control to the OFF position.
6. Wait five minutes then smell for gas. Be sure check near the floor as some types of gas are heavier than air.
7. If you smell gas after five minutes, immediately follow the instructions on page 3 of this manual. If you do not smell gas after five minutes, move the furnace gas valve manual control to the ON position.
8. Replace the burner compartment door.
9. Open the manual gas shutoff valve external to the furnace.
10. Turn on the electrical power to the furnace.
11. Adjust the thermostat to a setting above room temperature.
12. After the burners are lit, set the thermostat to desired temperature.

NOTE: There is an approximate 40 second delay between thermostat energizing and burner firing.

FURNACE SHUTDOWN

1. Set the thermostat to lowest setting.
2. Turn off the electrical power supply to the furnace.
3. Remove the burner compartment door and move the furnace gas valve manual control to the OFF position.
4. Close manual gas shutoff valve external to the furnace.
5. Replace the burner compartment door.

SYSTEM OPERATION

HEATING - Abnormal Operation

(Goodman 80% & 90% Variable Speed Furnaces - White Rodgers 50V51 Ignition Control)

The following presents the probable causes of questionable furnace operation and how to fix them. Look through the observation window in the blower access door and make a note of the number of flashes in sequence between pauses. Next, refer to the *Troubleshooting Chart* on the following pages for an interpretation of the LED signals and to the information in this section for a description of the problem.

1. **Internal Control Failure with Integrated Ignition Control.** Check for voltage to the furnace and low voltage at the control board. Check for blown fuse on the control board. If the control determines it has an internal fault, it enters a locked-out state. Any of the situations mentioned will cause the diagnostic LED to provide **no signal**. The control board should only be replaced only after all other checks from the *Troubleshooting Chart* have been verified.
2. **System Lockout.** If a flame is not sensed during the first seven (4) seconds after the gas valve is energized, the control turns off the gas. There will then be a 30 second delay while the induced draft blower is energized to purge the heat exchanger. The ignitor will again be energized and preheated for (8) seconds. The gas valve will then be energized. If flame is not sensed the gas valve will be de-energized and another purge will occur and a third ignitor warm up for (9) seconds will occur. The control will cycle the gas valve a total of three (3) times before it determines it cannot establish measurable combustion and enters a locked out state. The diagnostic light code for this problem is **one short flash** followed by a longer pause. The control can be reset and brought out of lockout mode by turning the thermostat off for more than (5) seconds and less than (20) seconds and then back on. It can also be reset by turning off the electrical disconnect switch to the furnace for a minimum of 5 seconds.

NOTE: The control board will automatically reset one hour after lockout occurs. If the furnace frequently has to be reset, it means that a problem exists that should be corrected. Refer to *Troubleshooting Chart* on the following pages for aid in determining the cause.

3. **Low Stage Pressure Switch Stuck Closed.** If the control senses the low stage pressure switch is closed when the induced draft blower is off, it waits until the fault is corrected. The diagnostic light code for this problem is **two short flashes** followed by a longer pause. The probable cause is either a faulty pressure switch or wiring.

4. **Pressure Switch Stuck Open.** If, after the induced draft blower is energized, the pressure switch does not close within 5 minutes, the control will go into a 1-hour lockout. The control will automatically reset from lockout and restart the ignition sequence. The diagnostic light code for this problem is **three short flashes** followed by a pause.



The probable causes are either disconnected hose to the pressure switch, faulty pressure switch or wiring, restricted air intake or flue piping.

5. **Open Primary or Auxiliary Limit.** If the limit control opens, the air circulator blower and induced draft blower will be turned on until the limit closes. The diagnostic light code for this problem is **four short flashes** followed by a pause. The probable cause is either low conditioned air flow due to dirty filter or resistance in duct work, faulty limit, faulty blower, or blower speed set to low.
6. **Flame Sensed with No Call for Heat.** If the control senses a flame when the gas valve is de-energized, it will run the air circulation blower and the induced draft blower continuously with no further furnace operation. The diagnostic flash code for this is a **five flashes**. The probable causes are either a short to ground in flame sense circuit, miswiring, lingering burner flame or a slow closing gas valve.
7. **Low Flame Sense Signal.** If the furnace continues to operate and the micro-amp signal from the flame sensor falls below specified level. The diagnostic light code for this problem is **seven flashes** followed by a pause. The probable cause is either a coated/oxidized sensor, incorrectly positioned sensor in burner flame or lazy burner flame due to improper gas pressure or combustion air.
8. **Reversed Polarity.** If the 115V or 24V AC power leads are reversed, the furnace will fail to operate. The diagnostic light code for this problem is **continuously flashing**. The probable cause is either the 115V AC power to furnace or integrated control module is reversed, the 24V AC wires to transformer are reversed, or poor unit ground.
9. **Check Igniter or No Ground Condition.** Check for broken or improperly connected igniter. Check for proper ground and correct. The diagnostic light code for this problem is **eight flashes** followed by a pause.
10. **High Stage Pressure Switch Stuck Open.** This condition can occur if the pressure switch hose is blocked or pinched. Check for blocked flue and/or inlet air pipe. Blocked drain, weak induced draft blower and malfunctioning pressure switch are possible. The diagnostic light code for this problem is **nine flashes** followed by a pause.

SYSTEM OPERATION

TROUBLESHOOTING CHART

AMH8, AMS8, ADS8, DDS8, DMS8, DHS8,
GME8, GMH8, GMS8, GDS8, GHS8

Symptoms of Abnormal Operation	Associated LED Code ²	Fault Description(s)	Possible Causes	Corrective Action	Cautions and Notes
<ul style="list-style-type: none"> Furnace fails to operate. Integrated control module diagnostic LED provides no signal. <ul style="list-style-type: none"> Furnace fails to operate. 	NONE	<ul style="list-style-type: none"> No 115 volt power to furnace, or no 24 volt power to integrated control module. Blown fuse or circuit breaker. <ul style="list-style-type: none"> Integrated control module has an internal fault. 	<ul style="list-style-type: none"> Manual disconnect switch OFF, door switch open, or 24 volt wires improperly connected or loose. Blown fuse or circuit breaker. <ul style="list-style-type: none"> Integrated control module has an internal fault. 	<ul style="list-style-type: none"> Assure 115 and 24 volt power to furnace integrated control module. Check integrated control module fuse (3A). Replace if necessary. Check for possible shorts in 115 and 24 volt circuits. Repair as necessary. <ul style="list-style-type: none"> Replace bad integrated control module. 	<ul style="list-style-type: none"> Turn power OFF prior to repair. Replace integrated control module fuse with 3A automotive fuse. Read precautions in "Electrostatic Discharge" section of manual.
<ul style="list-style-type: none"> Furnace fails to operate. Integrated control module diagnostic LED is flashing ONE (1) flash. 	 1 FLASH	<ul style="list-style-type: none"> Furnace lockout due to an excessive number of ignition attempt (1 total) and "retries" (2 total)¹. After a total of 3 tries for ignition, lockout occurs. "Recycles" are infinite. Auxiliary Limit Open 	<ul style="list-style-type: none"> Failure to establish flame. Cause may be no gas to burners, bad igniter or igniter alignment, improper orifices, or coated/oxidized or improperly connected flame sensor. Loss of flame after establishment. Cause may be interrupted gas supply, lazy burner flames (improper gas pressure or restriction in flue or improper induced draft blower performance). Insufficient conditioned air over the heat exchanger. Blocked filters, restrictive ductwork, improper circulator blower speed, or failed circulator blower. 	<ul style="list-style-type: none"> Locate and correct gas interruption. Replace or realign igniter. Check flame sense signal. Sand sensor if coated and/or oxidized. Check flue piping for blockage, proper length, elbows, and termination. Verify proper induced draft blower performance. Check circulator blower speed and performance. Correct speed or replace blower if necessary. 	<ul style="list-style-type: none"> Turn power OFF prior to repair. Igniter is fragile, handle with care. Clean flame sensor with steel wool. See "Combustion and Ventilation Air Requirements" and "Category I Venting (Vertical Venting)" section for details. See Product Data Bulletin for allowable rise range and proper circulator speed.
<ul style="list-style-type: none"> Furnace fails to operate. Integrated control module diagnostic LED is flashing TWO (2) flashes. 	 2 FLASHES	<ul style="list-style-type: none"> Pressure switch circuit is closed. Induced draft blower is not operating. 	<ul style="list-style-type: none"> Induced draft blower pressure switch contacts sticking. Shorts in pressure switch circuit. 	<ul style="list-style-type: none"> Replace induced draft blower pressure switch. Repair short. 	<ul style="list-style-type: none"> Turn power OFF prior to repair. Replace pressure switch with proper replacement part.
<ul style="list-style-type: none"> Induced draft blower runs continuously with no further furnace operation. Integrated control module diagnostic LED is flashing THREE (3) flashes. 	 3 FLASHES	<ul style="list-style-type: none"> Pressure switch circuit not closed. Induced draft blower is operating. 	<ul style="list-style-type: none"> Pressure switch hose blocked, pinched or connected improperly. Blocked flue or weak induced draft blower. Incorrect pressure switch setpoint or malfunctioning switch contacts. Loose or improperly connected wiring. 	<ul style="list-style-type: none"> Inspect pressure switch hose. Repair, if necessary. Inspect flue for blockage, proper length, elbows, and termination. Correct pressure switch setpoint or contact motion. Tighten or correct wiring connection. 	<ul style="list-style-type: none"> Turn power OFF prior to repair. See "Combustion and Ventilation Air Requirements" and "Category I Venting (Vertical Venting)" section for details. Replace pressure switch. with proper replacement part.







¹ Integrated control module will automatically attempt to reset from lockout after one hour.

² LED Flash code will cease if power to the control module is interrupted through the disconnect or door switch.

SYSTEM OPERATION

TROUBLESHOOTING CHART

AMH8, AMS8, ADS8, DDS8, DMS8, DHS8,
GME8, GMH8, GMS8, GDH8, GDS8, GHS8

Symptoms of Abnormal Operation	Associated LED Code ⁽²⁾⁽⁵⁾	Fault Description(s)	Possible Causes	Corrective Action	Cautions and Notes
<ul style="list-style-type: none"> • Circulator blower runs continuously. No furnace operation. • Integrated control module diagnostic LED is flashing FOUR (4) flashes. 	 4 FLASHES	<ul style="list-style-type: none"> • Primary limit circuit is open. 	<ul style="list-style-type: none"> • Insufficient conditioned air over the heat exchanger. Blocked filters, restrictive ductwork, improper circulator blower speed, or failed circulator blower. 	<ul style="list-style-type: none"> • Check filters and ductwork for blockage. Clean filters or remove obstruction. • Check circulator blower speed and performance. Correct speed or replace blower if necessary. 	<ul style="list-style-type: none"> • See Product Data Bulletin for allowable rise range and proper circulator speed. • Turn power OFF prior to repair.
<ul style="list-style-type: none"> • Induced draft blower and circulator blower runs continuously. No furnace operation. • Integrated control module diagnostic LED is flashing FIVE (5) flashes. 	 5 FLASHES	<ul style="list-style-type: none"> • Flame sensed with no call for heat. 	<ul style="list-style-type: none"> • Short to ground in flame sense circuit. • Lingering burner flame. • Slow closing gas valve. 	<ul style="list-style-type: none"> • Correct short at flame sensor or in flame sensor wiring. • Check for lingering flame. • Verify proper operation of gas valve. 	<ul style="list-style-type: none"> • Turn power OFF prior to repair.
<ul style="list-style-type: none"> • Furnace fails to operate. • Integrated control module diagnostic LED is flashing SIX (6) flashes. 	 6 FLASHES	<ul style="list-style-type: none"> • Rollout limit open. 	<ul style="list-style-type: none"> • Flame rollout. • Misaligned burners, blocked flue and/or air inlet pipe, or failed induced draft blower. • Loose or improperly connected wiring. 	<ul style="list-style-type: none"> • Check burners for proper alignment. • Check flue and air inlet piping for blockage, proper length, elbows, and termination. Correct as necessary. • Check induced draft blower for proper performance. Replace, if necessary. • Tighten or correct wiring connection. 	<ul style="list-style-type: none"> • See "Vent/Flue Pipe" section for piping details. • Replace induced draft blower with proper replacement part.
<ul style="list-style-type: none"> • Normal furnace operation. • Integrated control module diagnostic LED is flashing SEVEN (7) flashes. 	 7 FLASHES	<ul style="list-style-type: none"> • Flame sense microamp signal is low. 	<ul style="list-style-type: none"> • Flame sensor is coated/oxidized. • Flame sensor incorrectly positioned in burner flame. • Lazy burner flame due to improper gas pressure or combustion air. 	<ul style="list-style-type: none"> • Sand flame sensor is coated/oxidized. • Inspect for proper sensor alignment. • Check inlet air piping for blockage, proper length, elbows, and termination. • Compare current gas pressure to rating plate info. Adjust as needed. 	<ul style="list-style-type: none"> • Turn power OFF prior to repair. • Clean flame sensor with steel wool. • See "Vent/Flue Pipe" section for piping details. • See rating plate for proper gas pressure.
<ul style="list-style-type: none"> • Furnace not operating. • Integrated control module diagnostic LED is flashing EIGHT (8) flashes. 	 8 FLASHES ³	<ul style="list-style-type: none"> • Problem with igniter circuit. 	<ul style="list-style-type: none"> • Improperly connected igniter. • Bad igniter. • Poor unit ground. 	<ul style="list-style-type: none"> • Check and correct wiring from integrated control module to igniter. • Replace Bad igniter. • Check and correct unit ground wiring. 	<ul style="list-style-type: none"> • Turn power OFF prior to repair. • Replace igniter with proper replacement part.
<ul style="list-style-type: none"> • Integrated control module diagnostic LED is flashing continuously. 	 CONTINUOUS FLASHING	<ul style="list-style-type: none"> • Polarity of 115 volt or 24 volt power is reversed. 	<ul style="list-style-type: none"> • Polarity of 115 volt AC power to furnace or integrated control module is reversed. • Wires to 24 volt side of transformer are reversed. • Poor unit ground. 	<ul style="list-style-type: none"> • Review wiring diagram to correct polarity. • Reverse wires connected to 24 volt side of transformer. • Verify proper ground. Correct if necessary. • Check and correct wiring if necessary. 	<ul style="list-style-type: none"> • Turn power OFF prior to repair.
<ul style="list-style-type: none"> • LED is steady on 	On Steady	• Normal operation.	• Normal operation.	• None.	• Normal operation.

² LED Flash codes will cease if power to the control module is interrupted through the disconnect or door switch.





³ 8 Flashes - applies to AMS8/ADS8 Models only (Silicon Nitride Models Only)

⁵ Integrated circuit boards on new furnace models AMH, GMH, GCH, GMS, GDS, GHS, GKS hold last 5 faults for service reference.

SYSTEM OPERATION

TROUBLESHOOTING CHART

AMS9, ACS9, DMS9, DCS9, GMS9,
GCS9, GKS9, AMS95, GMS95

Symptoms of Abnormal Operation	Associated LED Code ²	Fault Description(s)	Possible Causes	Corrective Action	
<ul style="list-style-type: none"> Furnace fails to operate. Integrated control module diagnostic LED provides no signal. 	NONE	<ul style="list-style-type: none"> No 115 volt power to furnace, or no 24 volt power to integrated control module. Blown fuse or circuit breaker. Integrated control module has an internal fault. 	<ul style="list-style-type: none"> Manual disconnect switch OFF, door switch open, or 24 volt wires improperly connected or loose. Blown fuse or circuit breaker. Integrated control module has internal fault. 	<ul style="list-style-type: none"> Assure 115 and 24 volt power to furnace integrated control module. Check integrated control module fuse (3A). Replace if necessary. Check for possible shorts in 115 and 24 volt circuits. Repair as necessary. Replace bad integrated control module. 	<ul style="list-style-type: none"> Turn power OFF prior to repair. Replace integrated control module fuse with 3A automotive fuse. Read precautions in "Electrostatic Discharge" section of manual.
<ul style="list-style-type: none"> LED is Steady On 	 CONTINUOUS ON	<ul style="list-style-type: none"> Normal Operation 	<ul style="list-style-type: none"> Normal operation. 	<ul style="list-style-type: none"> None. 	<ul style="list-style-type: none"> Normal operation.
<ul style="list-style-type: none"> Furnace fails to operate. Integrated control module diagnostic LED is flashing ONE (1) time. 	 1 FLASH	<ul style="list-style-type: none"> Furnace lockout due to an excessive number of ignition "retries" (3 total)¹. "Recycles" are infinite. 	<ul style="list-style-type: none"> Failure to establish flame. Cause may be no gas to burners, front cover pressure switch stuck open, bad igniter or igniter alignment, improper orifices, or coated/oxidized or improperly connected flame sensor. Loss of flame after establishment. Cause may be interrupted gas supply, lazy burner flames (improper gas pressure or restriction in flue and/or combustion air piping), front cover pressure switch opening, or improper induced draft blower performance. 	<ul style="list-style-type: none"> Locate and correct gas interruption. Check front cover pressure switch operation (hose, wiring, contact operation). Correct if necessary. Replace or realign igniter. Check flame sense signal. Sand sensor if coated and/or oxidized. Check flue piping for blockage, proper length, elbows, and termination. Verify proper induced draft blower performance. 	<ul style="list-style-type: none"> Turn power OFF prior to repair. Igniter is fragile, handle with care. Sand flame sensor with emery cloth. See "Vent/Flue Pipe" section for piping details.
<ul style="list-style-type: none"> Furnace fails to operate. Integrated control module diagnostic LED is flashing TWO (2) times. 	 2 FLASHES	<ul style="list-style-type: none"> Pressure switch circuit is closed. Induced draft blower is not operating. 	<ul style="list-style-type: none"> Induced draft blower pressure switch contacts sticking. Shorts in pressure switch circuit. 	<ul style="list-style-type: none"> Replace induced draft blower pressure switch. Repair short. 	<ul style="list-style-type: none"> Turn power OFF prior to repair. Replace pressure switch with proper replacement.
<ul style="list-style-type: none"> Induced draft blower runs continuously with no further furnace operation. Integrated control module diagnostic LED is flashing THREE (3) times. 	 3 FLASHES	<ul style="list-style-type: none"> Pressure switch circuit <u>not</u> closed. Induced draft blower is operating. 	<ul style="list-style-type: none"> Pressure switch hose blocked, pinched or connected improperly. Blocked flue and/or inlet air pipe, blocked drain system, or weak induced draft blower. Incorrect pressure switch setpoint or malfunctioning switch contacts. Loose or improperly connected wiring. 	<ul style="list-style-type: none"> Inspect pressure switch hose. Repair, if necessary. Inspect flue and/or inlet air piping for blockage, proper length, elbows, and termination. Check drain system. Correct as necessary. Correct pressure switch setpoint or contact motion. Tighten or correct wiring connection. 	<ul style="list-style-type: none"> Turn power OFF prior to repair. Replace pressure switch with proper replacement part.







¹ Integrated control module will automatically attempt to reset from lockout after one hour.

² LED Flash code will cease if power to the control module is interrupted through the disconnect or door switch.

SYSTEM OPERATION

TROUBLESHOOTING CHART

AMS9, ACS9, DMS9, DCS9, GMS9,
GCS9, GKS9, AMS95, GMS95





Symptoms of Abnormal Operation	Associated LED Code ²	Fault Description(s)	Possible Causes	Corrective Action	Cautions and Notes
<ul style="list-style-type: none"> • Circulator blower runs continuously. No furnace operation. • Integrated control module diagnostic LED is flashing FOUR (4) flashes. 	 4 FLASHES	<ul style="list-style-type: none"> • Primary or auxiliary limit circuit is open. 	<ul style="list-style-type: none"> • Insufficient conditioned air over the heat exchanger. Blocked filters, restrictive ductwork, improper circulator blower speed, or failed circulator blower. • Faulty primary or auxiliary limit switch. • Loose or improperly connected wiring. 	<ul style="list-style-type: none"> • Check primary/auxiliary limit. Replace if necessary • Check filters and ductwork for blockage. Clean filters or remove obstruction. • Check circulator blower speed and performance. Correct speed or replace blower if necessary. • Tighten or correct wiring connection. 	<ul style="list-style-type: none"> • Turn power OFF prior to repair. • Replace primary/auxiliary limit switch with proper replacement part. • Replace blower with correct replacement part.
<ul style="list-style-type: none"> • Induced draft blower and circulation blower runs continuously. No furnace operation. • Integrated control module diagnostic LED is flashing FIVE (5) flashes. 	 5 FLASHES	<ul style="list-style-type: none"> • Flame sensed with no call for heat. 	<ul style="list-style-type: none"> • Short to ground in flame sense circuit. 	<ul style="list-style-type: none"> • Correct short at flame sensor or in flame sensor wiring. 	<ul style="list-style-type: none"> • Turn power OFF prior to repair.
<ul style="list-style-type: none"> • Circulator blower runs continuously. No furnace operation. • Integrated control module diagnostic LED is flashing SIX (6) flashes. 	 6 FLASHES	<ul style="list-style-type: none"> • Rollout limit circuit is open. 	<ul style="list-style-type: none"> • Flame rollout. • Misaligned burners, blocked flue and/or air inlet pipe, or failed induced draft blower. • Loose or improperly connected wiring. • Faulty rollout limit. 	<ul style="list-style-type: none"> • Check burners for proper alignment. • Check flue and air inlet piping for blockage, proper length, elbows, and termination. Correct as necessary. • Check induced draft blower for proper performance. Replace, if necessary. • Tighten or correct wiring connection. 	<ul style="list-style-type: none"> • Turn power OFF prior to repair. • See "Vent/Flue Pipe" section for piping details. • Replace rollout limit with correct replacement part. • Replace induced draft blower with correct replacement part.
<ul style="list-style-type: none"> • Normal furnace operation. • Integrated control module diagnostic LED is flashing SEVEN (7) flashes. 	 7 FLASHES	<ul style="list-style-type: none"> • Flame sense microamp signal is low. 	<ul style="list-style-type: none"> • Flame sensor is coated/oxidized. • Flame sensor incorrectly positioned in burner flame. • Lazy burner flame due to improper gas pressure or combustion air. 	<ul style="list-style-type: none"> • Sand flame sensor is coated/oxidized. • Inspect for proper sensor alignment. • Check inlet air piping for blockage, proper length, elbows, and termination. • Compare current gas pressure to rating plate info. Adjust as needed. 	<ul style="list-style-type: none"> • Turn power OFF prior to repair. • Sand flame sensor with emery cloth. • See "Vent/Flue Pipe" section for piping details. • See rating plate for proper gas pressure.
<ul style="list-style-type: none"> • Furnace not operating. • Integrated control module diagnostic LED is flashing EIGHT (8) flashes. 	 8 FLASHES	<ul style="list-style-type: none"> • Problem with igniter circuit. 	<ul style="list-style-type: none"> • Improperly connected igniter. • Bad igniter. • Poor unit ground. 	<ul style="list-style-type: none"> • Check and correct wiring from integrated control module to igniter. • Replace bad igniter. • Check and correct unit ground wiring. 	<ul style="list-style-type: none"> • Turn power OFF prior to repair. • Replace igniter with proper replacement part.
<ul style="list-style-type: none"> • Furnace fails to operate. • Integrated control module diagnostic LED is flashing continuously. 	 CONTINUOUS/ RAPID FLASH	<ul style="list-style-type: none"> • Polarity of 115 or 24 volt power is reversed. 	<ul style="list-style-type: none"> • Polarity of 115 volt AC power to furnace or integrated control module is reversed. • Wires to 24 volt side of transformer are reversed. • Poor unit ground. 	<ul style="list-style-type: none"> • Review wiring diagram to correct polarity. • Reverse wires going to 24 volt side of transformer. • Verify proper ground. Correct if necessary. 	<ul style="list-style-type: none"> • Turn power OFF prior to repair.

² LED flash code will cease if power to control module is interrupted through the disconnect or door switch.

³ 8 Flashes - Applies to AMS95, AMS9, ACS9 Models only (Silicon Nitride Models Only)

SYSTEM OPERATION

TROUBLESHOOTING CHART ADV8, AMV8, ACV9, AMV9, GMV8, GCV9, GMV9

Symptoms of Abnormal Operation	Associated LED Code ²	Fault Description(s)	Possible Causes	Corrective Action	Cautions and Notes
<ul style="list-style-type: none"> Furnace fails to operate. Integrated control module diagnostic LED provides no signal. 	NONE	<ul style="list-style-type: none"> No 115 volt power to furnace, or no 24 volt power to integrated control module. Blown fuse or circuit breaker. Integrated control module has an internal fault 	<ul style="list-style-type: none"> Manual disconnect switch OFF, door switch open, or 24 volt wires improperly connected or loose. Blown fuse or circuit breaker. Integrated control module has an internal fault 	<ul style="list-style-type: none"> Assure 115 and 24 volt power to furnace integrated control module. Check integrated control module fuse (3A). Replace if necessary. Check for possible shorts in 115 and 24 volt circuits. Repair as necessary. Replace bad integrated control module. 	<ul style="list-style-type: none"> Turn power OFF prior to repair. Replace integrated control module fuse with 3A automotive fuse. Read precautions in "Electrostatic Discharge" section of manual.
<ul style="list-style-type: none"> LED is steady ON. 	 CONTINUOUS ON	<ul style="list-style-type: none"> Normal operation. 	<ul style="list-style-type: none"> Normal operation. 	<ul style="list-style-type: none"> None. 	<ul style="list-style-type: none"> Normal operation.
<ul style="list-style-type: none"> Furnace fails to operate. Integrated control module diagnostic LED is flashing ONE (1) flash. 	 1 FLASH	<ul style="list-style-type: none"> Furnace lockout due to an excessive number of ignition "retries" (3 total)¹. Auxiliary limit open 	<ul style="list-style-type: none"> Failure to establish flame. Cause may be no gas to burners, bad igniter or igniter alignment, improper orifices, or coated/oxidized or improperly connected flame sensor. Loss of flame after establishment. Cause may be interrupted gas supply, lazy burner flames (improper gas pressure or restriction in flue or improper induced draft blower performance). Insufficient conditioned air over the heat exchanger. Blocked filters, restrictive ductwork, improper circulator blower speed, or failed circulator blower. 	<ul style="list-style-type: none"> Locate and correct gas interruption. Replace or realign igniter. Check flame sense signal. Sand sensor if coated and/or oxidized. Check flue piping for blockage, proper length, elbows, and termination. Verify proper induced draft blower performance. Check circulator blower speed and performance. Correct speed or replace blower if necessary. 	<ul style="list-style-type: none"> Turn power OFF prior to repair. Igniter is fragile, handle with care. Sand flame sensor with emery cloth. See "Combustion and Ventilation Air Requirements" and "Category I Venting (Vertical Venting)" section for details. See Product Data Bulletin for allowable rise range and proper circulator speed.
<ul style="list-style-type: none"> Furnace fails to operate. Integrated control module diagnostic LED is flashing TWO (2) flashes. 	 2 FLASHES	<ul style="list-style-type: none"> Low stage pressure switch circuit is closed. Induced draft blower is not operating. 	<ul style="list-style-type: none"> Induced draft blower pressure switch contacts sticking. Shorts in pressure switch circuit. 	<ul style="list-style-type: none"> Replace induced draft blower pressure switch. Repair short. 	<ul style="list-style-type: none"> Turn power OFF prior to repair. Replace pressure switch with proper replacement part.
<ul style="list-style-type: none"> Induced draft blower runs continuously with no further furnace operation. Integrated control module diagnostic LED is flashing THREE (3) flashes. 	 3 FLASHES	<ul style="list-style-type: none"> Pressure switch circuit not closed. Induced draft blower is operating. 	<ul style="list-style-type: none"> Pressure switch hose blocked, pinched or connected improperly. Blocked flue or weak induced draft blower. Incorrect pressure switch setpoint or malfunctioning switch contacts. Loose or improperly connected wiring. 	<ul style="list-style-type: none"> Inspect pressure switch hose. Repair, if necessary. Inspect flue for blockage, proper length, elbows, and termination. Correct pressure switch setpoint or contact motion. Tighten or correct wiring connection. 	<ul style="list-style-type: none"> Turn power OFF prior to repair. See "Combustion and Ventilation Air Requirements" and "Category I Venting (Vertical Venting)" section for details. Replace pressure switch with proper replacement part.







¹ Integrated control module will automatically attempt to reset from lockout after one hour.

² LED flash code will cease if power to control module is interrupted through the disconnect or door switch.

⁴ Applies to ADV8, AMV8, GMV8 only.

SYSTEM OPERATION

TROUBLESHOOTING CHART ADV8, AMV8, ACV9, AMV9, GMV8, GCV9, GMV9

Symptoms of Abnormal Operation	Associated LED Code ²	Fault Description(s)	Possible Causes	Corrective Action	Cautions and Notes
<ul style="list-style-type: none"> Circulator blower runs continuously. No furnace operation. Integrated control module diagnostic LED is flashing FOUR (4) flashes. 	 4 FLASHES	<ul style="list-style-type: none"> Primary limit circuit is open. 	<ul style="list-style-type: none"> Insufficient conditioned air over the heat exchanger. Blocked filters, restrictive ductwork, improper circulator blower speed, or failed circulator blower. Flame rollout. Misaligned burners, blocked flue and/or air inlet pipe, or failed induced draft blower. Loose or improperly connected wiring. 	<ul style="list-style-type: none"> Check filters and ductwork for blockage. Clean filters or remove obstruction. Check circulator blower speed and performance. Correct speed or replace blower if necessary. Check burners for proper alignment. Check flue and air inlet piping for blockage, proper length, elbows, and termination. Correct as necessary. Check induced draft blower for proper performance. Replace, if necessary. Tighten or correct wiring connection. 	<ul style="list-style-type: none"> Turn power OFF prior to repair. See Product Data Bulletin for allowable rise range and proper circulator speed. See "Vent/Flue Pipe" section for piping details. Replace pressure switch with proper replacement part.
<ul style="list-style-type: none"> Integrated control module diagnostic LED is flashing FIVE (5) times. Induced draft blower and circulator blower run continuously. No furnace operation. 	 5 FLASHES	<ul style="list-style-type: none"> Flame sensed with no call for heat. 	<ul style="list-style-type: none"> Short to ground in flame sense circuit. Lingering burner flame. Slow closing gas valve 	<ul style="list-style-type: none"> Correct short at flame sensor or in flame sensor wiring. Check for lingering flame Verify proper operation of gas valve 	<ul style="list-style-type: none"> Turn power OFF prior to repair.
<ul style="list-style-type: none"> Furnace fails to operate. Integrated control module diagnostic LED is flashing continuously. 	 CONTINUOUS FLASHING	<ul style="list-style-type: none"> Polarity of 115 volt power is reversed. 	<ul style="list-style-type: none"> Polarity of 115 volt AC power to furnace or integrated control module is reversed. Poor unit ground. 	<ul style="list-style-type: none"> Review wiring diagram to correct polarity. Verify proper ground. Correct if necessary. Check and correct wiring. 	<ul style="list-style-type: none"> Turn power OFF prior to repair.
<ul style="list-style-type: none"> Normal furnace operation. Integrated control module diagnostic LED is flashing SEVEN (7) flashes. 	 7 FLASHES	<ul style="list-style-type: none"> Flame sense microamp signal is low. 	<ul style="list-style-type: none"> Flame sensor is coated/oxidized. Flame sensor incorrectly positioned in burner flame. Lazy burner flame due to improper gas pressure or combustion air. 	<ul style="list-style-type: none"> Sand flame sensor is coated/oxidized. Inspect for proper sensor alignment. Check inlet air piping for blockage, proper length, elbows, and termination. Compare current gas pressure to rating plate info. Adjust as needed. 	<ul style="list-style-type: none"> Turn power OFF prior to repair. Sand flame sensor with emery cloth. See "Vent/Flue Pipe" section for piping details. See rating plate for proper gas pressure.
<ul style="list-style-type: none"> Furnace not operating. Integrated control module diagnostic LED is flashing EIGHT (8) flashes. 	 8 FLASHES	<ul style="list-style-type: none"> Problem with igniter circuit. 	<ul style="list-style-type: none"> Improperly connected igniter Bad igniter Poor unit ground 	<ul style="list-style-type: none"> Check and correct wiring from integrated control module to igniter Replace bad igniter Check and correct unit ground wiring 	<ul style="list-style-type: none"> Turn power OFF prior to repair. Replace igniter with replacement part.
<ul style="list-style-type: none"> Furnace operating on low stage gas with high stage induced draft blower High stage circulator blower (temperature, of conditioned air, lower than typical). Integrated control module diagnostic LED is flashing NINE (9) flashes. 	 9 FLASHES	<ul style="list-style-type: none"> High stage pressure switch circuit does not close in response to high stage induced draft blower operation. 	<ul style="list-style-type: none"> Pressure switch hose blocked, pinched or connected improperly. Blocked flue and/or inlet air pipe, blocked drain system, or weak induced draft blower. Incorrect pressure switch setpoint or malfunctioning switch contacts. Loose or improperly connected wiring. 	<ul style="list-style-type: none"> Inspect pressure switch hose. Repair, if necessary. Inspect flue and/or inlet air piping for blockage, proper length, elbows, and termination. Check drain system. Correct as necessary. Correct pressure switch setpoint or contact motion. Tighten or correct wiring connection. 	<ul style="list-style-type: none"> Turn power OFF prior to repair. Replace pressure switch with proper replacement part.

¹Integrated control module will automatically attempt to reset from lockout after one hour.

² LED flash code will cease if power to control module is interrupted through the disconnect or door switch.

⁴ Applies to ADV8, AMV8, GMV8 only.

POLARIZATION AND PHASING

As more and more electronic's are introduced to the Heating Trade, Polarization of incoming power and phasing of primary to secondary voltage on transformers becomes more important.

Polarization has been apparent in the Appliance industry since the introduction of the three prong plug, however, the Heating Industry does not use a plug for incoming power, but is hard wired.

Some of the electronic boards being used today, with flame rectification, will not function properly and/or at all without polarization of incoming power. Some also require phasing between the primary and secondary sides of step-down transformers.

To instill new working habits for our trade, we recommend that these two items be checked during normal installation and/or service calls. See as follows:

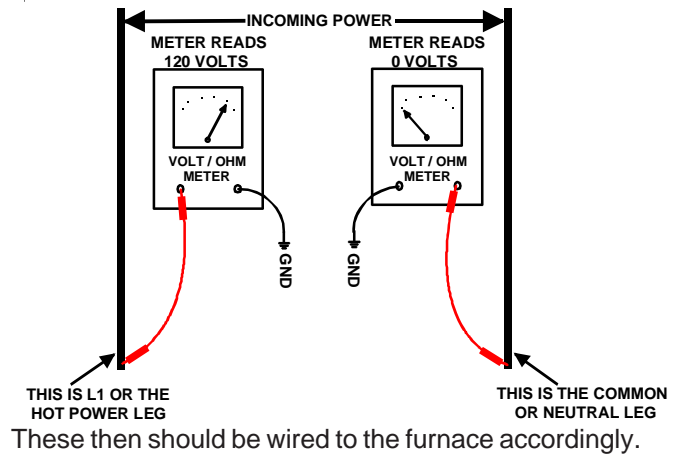

CHECKING FOR PHASING - PRIMARY TO SECONDARY OF UNMARKED TRANSFORMERS*

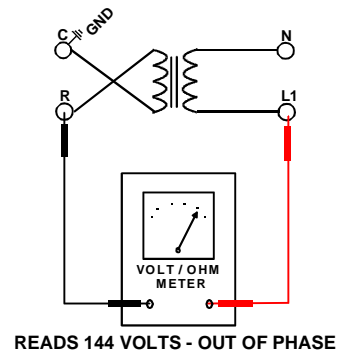
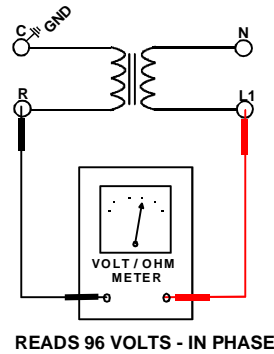
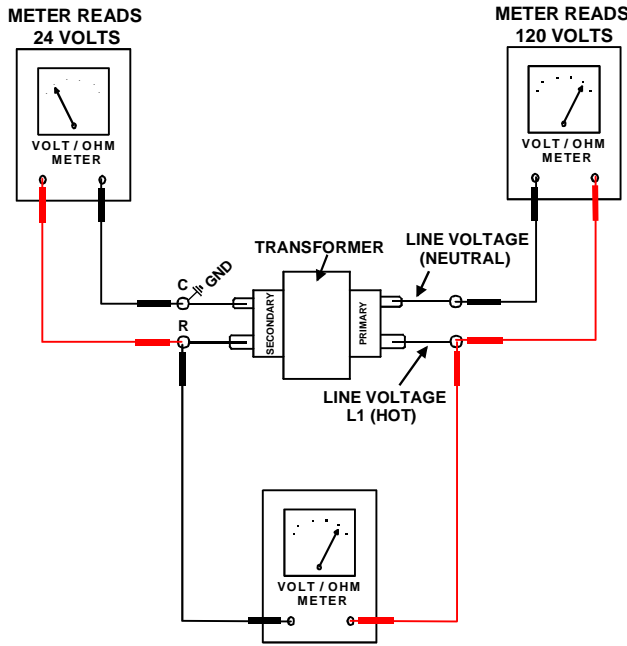

If meter reads approximately 96 volts - the primary to secondary are in phase - if reads approximately 144 volts out of phase - reverse low voltage wires.

***NOTE:** For flame rectification the common side of the secondary voltage (24 V) is cabinet grounded. If you were to bench test a transformer the primary neutral and secondary common must be connected together for testing purposes.

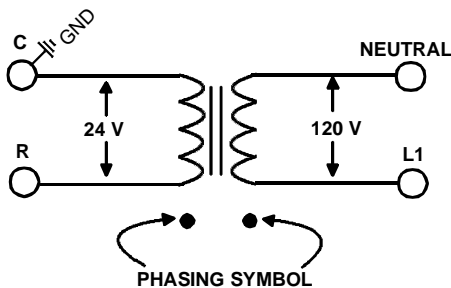





Some transformers will display phasing symbols as shown in the illustration to the left to assist in determining proper transformer phasing.

Checking for polarization and phasing should become a habit in servicing. Let's start now.

NOTE: Newer integrated ignition controls have a diagnostic flash code for reversed polarity (Refer to *Troubleshooting-Diagnostic Chart* for LED Codes).

MAINTENANCE

 WARNING	
HIGH VOLTAGE DISCONNECT ALL POWER BEFORE SERVICING OR INSTALLING THIS UNIT. MULTIPLE POWER SOURCES MAY BE PRESENT. FAILURE TO DO SO MAY CAUSE PROPERTY DAMAGE, PERSONAL INJURY OR DEATH.	

 WARNING	
HIGH VOLTAGE DISCONNECT ALL POWER BEFORE SERVICING, REMOVING THE FILTER OR PREFORING ANY OTHER MAINTENEACE. MULTIPLE POWER SOURCES MAY BE PRESENT. FAILURE TO DO SO MAY CAUSE PROPERTY DAMAGE, PERSONAL INJURY OR DEATH.	

 CAUTION
IF YOU MUST HANDLE THE ITNITOR, HANDLE WITH CARE. TOUCHING THE IGNITOR BODY WITH BARE FINGERS, ROUGH HANDLING, OR VIBRATION COULD RESULT IN EARLY IGNITOR FAILURE. ONLY A QUALIFIED SERVICER SHOULD EVER HANDLE THE IGNITOR.

ANNUAL INSPECTION

The furnace should be inspected by a qualified installer, or service agency at least once per year. This check should be performed at the beginning of the heating season. This will ensure that all furnace components are in proper working order and that the heating system functions appropriately. Pay particular attention to the following items. Repair or service as necessary.

- Flue pipe system. Check for blockage and/or leakage. Check the outside termination and the connections at and internal to the furnace.
- Combustion air intake pipe system (where applicable). Check for blockage and/or leakage. Check the outside termination and the connection at the furnace.
- Heat exchanger. Check for corrosion and/or buildup within the heat exchanger passageways.
- Burners. Check for proper ignition, burner flame, and flame sense.
- Drainage system. Check for blockage and/or leakage. Check hose connections at and internal to furnace.
- Wiring. Check electrical connections for tightness and/or corrosion. Check wires for damage.
- Filters.

AIR FILTER

 WARNING
NEVER OPERATE FURNACE WIHTOUT A FILTER INSTALLED AS DUST AND LINT WILL BUILD UP ON INTERNAL PARTS RESULTING IN LOSS OF EFFICIENCY, EQUIPMENT DAMAMGE, AND POSSIBLE FIRE.

Filters must be used with this furnace. Filters do not ship with these furnaces but must be provided by the installer for proper furnace operation.

Remember that dirty filters are the most common cause of inadequate heating or cooling performance.

Maintenance

Improper filter maintenance is the most common cause of inadequate heating or cooling performance. Filters should be cleaned (permanent) or replaced (disposable) every two months or as required. It is the owner's responsibility to keep air filters clean. When replacing a filter, it must be replaced with a filter of the same type and size.

Filter Removal

Depending on the installation, differing filter arrangements can be applied. Filters can be installed in the central return register, the bottom of the blower compartment (upflow only), a side panel external filter rack kit (upflow only), or the ductwork above a counterflow furnace. A media air filter or electronic air cleaner can be used as an alternate filter. The filter sizes given in the *Product Design* section of this manual or the product *Specification Sheet* must be followed to ensure proper unit performance. Refer to the following information for removal and installation of filters.

FILTER REMOVAL PROCEDURE

Media Air Filter or Electronic Air Cleaner Removal

Follow the manufacturer's directions for service.

Upright Counterflow Filter Removal

To remove filters from the ductwork above an upright counterflow installation:

1. Turn off electrical power to furnace.
2. Remove access door in ductwork above furnace.
3. Remove filters.
4. Remove blower compartment door. Vacuum compartment. Replace blower compartment door.
5. Replace filters opposite of removal.
6. Replace access door in ductwork.

Horizontal Unit Filter Removal

Filters in horizontal installations are located in the central return register.

INDUCED DRAFT AND CIRCULATION BLOWERS

The bearings in the induced draft blower and circulator blower motors are permanently lubricated by the manufacturer. No further lubrication is required. Check motor windings for accumulation of dust which may cause overheating. Clean as necessary.

MAINTENANCE

CONDENSATE DRAINAGE SYSTEM (QUALIFIED SERVICER ONLY)

The drain tubes, standpipe, and field supplied drain line must be checked annually and cleaned as often as necessary to ensure proper condensate drainage.

FLUE PASSAGES (QUALIFIED SERVICER ONLY)

At the start of each heating season, inspect and, if necessary, clean the furnace flue passages.

CLEANING FLUE PASSAGES (QUALIFIED SERVICER ONLY)

1. Turn OFF the electrical power and gas supply to the furnace.
2. Disconnect the gas line and remove the burner/ manifold assembly by removing the screws securing the assembly to the partition panel.
3. Disconnect the flue pipe system from the induced draft blower.
4. Remove the induced draft blower and, drain and pressure tap hoses from the recuperator coil front cover.
5. Remove the recuperator coil front cover to expose the coil tubes and turbulators.
6. Remove the recuperator coil turbulators individually by slowly pulling each turbulator forward firmly.
7. Clean the recuperator coil tubes using a long handle wire brush, such as a gun cleaning brush.
8. Clean the primary heat exchanger tubes using a wire brush attached to a length of high grade stainless steel cable, such as drain cleanout cable. Attach a variable speed reversible drill to the other end of the cable. Slowly rotate the cable with the drill and insert it into one of the heat exchanger tubes. While reversing the drill, work the cable in and out several times to obtain sufficient cleaning. Repeat for each tube.
9. Clean residue from furnace using a vacuum cleaner.
10. Replace the parts removed in the previous steps in reverse order.
11. Turn on electrical power and gas to furnace. Check for leaks and proper unit operation.
12. Severe heat exchanger fouling is an indication of an operational problem. Perform the steps listed in the *System Operation* section of this manual to reduce the chances of repeated fouling.

FLAME SENSOR (QUALIFIED SERVICER ONLY)

Under some conditions, the fuel or air supply can create a nearly invisible coating on the flame sensor. This coating acts as an insulator, causing a drop in the flame sensing signal. If this occurs, a qualified servicer must carefully clean the flame sensor with steel wool. After cleaning, the flame sensor output should be as listed on the specification sheet.

BURNERS

⚠ WARNING

HIGH VOLTAGE
ELECTRICAL COMPONENTS ARE CONTAINED IN BOTH COMPARTMENTS. TO AVOID ELECTRICAL SHOCK, INJURY OR DEATH, DO NOT REMOVE ANY INTERNAL COMPARTMENT COVERS OR ATTEMPT ANY ADJUSTMENT. CONTACT A QUALIFIED SERVICE AGENT AT ONCE IF AN ABNORMAL FLAME APPEARANCE SHOULD DEVELOP.



Periodically during the heating season make a visual check of the burner flames. Turn the furnace on at the thermostat. Wait a few minutes since any dislodged dust will alter the normal flame appearance. Flames should be stable, quiet, soft and blue with slightly orange tips. They should not be yellow. They should extend directly outward from the burner ports without curling downward, floating or lifting off the ports.

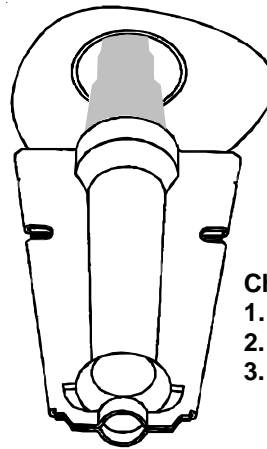

Check the burner flames for:

1. Good adjustment
2. Stable, soft and blue
3. Not curling, floating, or lifting off.

Burner Flame

TEST EQUIPMENT

Proper test equipment for accurate diagnosis is as essential as regular hand tools.

The following is a must for every service technician and service shop.

1. Dial type thermometers or thermocouple meter (optional) - to measure dry bulb temperature.
2. Amprobe - to measure amperage and voltage.
3. Volt-Ohm Meter - testing continuity, capacitors, and motor windings.
4. Inclined Manometer - to measure static pressure, pressure drop across coils, filters, and draft.
5. Water Manometer (12") - to test gas inlet and manifold pressure.

Other recording type instruments can be essential in solving abnormal problems, however, in many instances they may be rented from local sources.

Proper equipment promotes faster, more efficient service and accurate repairs resulting in fewer call backs.

MAINTENANCE

HEATING PERFORMANCE TEST

Before attempting to diagnose an operating fault, run a heating performance test and apply the results to the *Service Problem Analysis Guide*.

To conduct a heating performance test, the BTU input to the furnace must be calculated.

After the heating cycle has been in operation for at least fifteen minutes and with all other gas appliances turned off, the gas meter should be clocked.

To find the BTU input, multiply the number of cubic feet of gas consumed per hour by the heating value of the gas being used. (The calorific value of the gas being used is found by contacting your local utility.)

EXAMPLE: It is found by the gas meter, that it takes forty (40) seconds for the hand on the cubic foot dial to make one complete revolution, with all appliances off, except the furnace. Take this information and locate it on the gas rate chart. Observe the forty (40) seconds, locate and read across to the one (1) cubic foot dial column. There we find the number 90, which shows that ninety (90) cubic feet of gas will be consumed in one (1) hour.

Let's assume the local gas utility has stated that the calorific value of the gas is 1,025 BTU per cubic foot.

Multiplying the ninety (90) cubic feet by 1,025 BTU per cubic foot gives us an input of 92,250 BTUH.

Checking the BTU input on the rating plate of the furnace being tested.

EXAMPLE:

INPUT: 92,000 BTU/HR

OUTPUT CAP: 84,000

Should the figure you calculated not fall within five (5) percent of the nameplate rating of the unit, adjust the gas valve pressure regulator or resize orifices.



ALWAYS CONNECT A MONOMETER TO THE OUTLET TAP AT THE GAS VALVE BEFORE ADJUSTING THE PRESSURE REGULATOR. IN NO CASE SHOULD THE FINAL MANIFOLD PRESSURE VARY MORE THAN PLUS OR MINUS .3 INCHES WATER COLUMN FROM 3.5 INCHES WATER COLUMN FOR NATURAL GAS OR 10 INCHES WATER COLUMN FOR PROPANE GAS.

To adjust the pressure regulator on the gas valve, turn down (clockwise) to increase pressure and input, and out (counterclockwise) to decrease pressure and input.

Since normally propane gas is not installed with a gas meter, clocking will be virtually impossible. The gas orifices used with propane are calculated for 2500 BTU per cubic foot gas and with proper inlet pressures and correct piping size, full capacity will be obtained.

With propane gas, no unit gas valve regulator is used; however, the second stage supply line pressure regulator should be adjusted to give 11" water column with all other gas consuming appliances running.

The dissipation of the heat transferred to the heat exchanger is now controlled by the amount of air circulated over its surface.

The amount (CFM) of air circulated is governed by the external static pressure in inches of water column of duct work, cooling coil, registers, etc., applied externally to the unit versus the motor speed tap (direct drive) or pulley adjustments of the motor and blower (belt drive).

A properly operating unit must have the BTU per hour input and CFM of air, within the limits shown to prevent short cycling of the equipment. As the external static pressure goes up, the temperature rise will also increase. Consult the proper tables for temperature rise limitation.

SERVICING

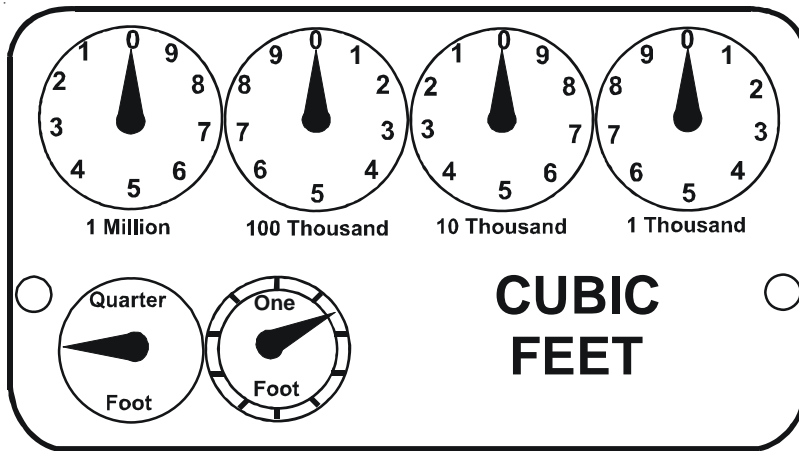

GAS RATE -- CUBIC FEET PER HOUR											
Seconds for One Revolution	Size of Test Dial					Seconds for One Revolution	Size of Test Dial				
	1/4 cu/ft	1/2 cu/ft	1 cu/ft	2 cu/ft	5 cu/ft		1/4 cu/ft	1/2 cu/ft	1 cu/ft	2 cu/ft	5 cu/ft
10	90	180	360	720	1800	36	25	50	100	200	500
11	82	164	327	655	1636	37	--	--	97	195	486
12	75	150	300	600	1500	38	23	47	95	189	474
13	69	138	277	555	1385	39	--	--	92	185	462
14	64	129	257	514	1286	40	22	45	90	180	450
15	60	120	240	480	1200	41	--	--	--	176	439
16	56	113	225	450	1125	42	21	43	86	172	429
17	53	106	212	424	1059	43	--	--	--	167	419
18	50	100	200	400	1000	44	--	41	82	164	409
19	47	95	189	379	947	45	20	40	80	160	400
20	45	90	180	360	900	46	--	--	78	157	391
21	43	86	171	343	857	47	19	38	76	153	383
22	41	82	164	327	818	48	--	--	75	150	375
23	39	78	157	313	783	49	--	--	--	147	367
24	37	75	150	300	750	50	18	36	72	144	360
25	36	72	144	288	720	51	--	--	--	141	355
26	34	69	138	277	692	52	--	--	69	138	346
27	33	67	133	265	667	53	17	34	--	136	340
28	32	64	129	257	643	54	--	--	67	133	333
29	31	62	124	248	621	55	--	--	--	131	327
30	30	60	120	240	600	56	16	32	64	129	321
31	--	--	116	232	581	57	--	--	--	126	316
32	28	56	113	225	563	58	--	31	62	124	310
33	--	--	109	218	545	59	--	--	--	122	305
34	26	53	106	212	529	60	15	30	60	120	300
35	--	--	103	206	514						

SERVICING

Service Problem	No Heat			Unsatisfactory Heat				Test Method Remedy	See Service Procedure Reference		
	SYMPTOM	System Will Not Start	Burner Won't Ignite	Burner Ignites-Locks Out	Burner Shuts Off prior to T'Stat being Satisfied	Short Cycles	Long Cycles			Soot and /or Fumes	Too Much Heat
POSSIBLE CAUSE DOTS IN ANALYSIS GUIDE INDICATE "POSSIBLE CAUSE"											
Power Failure		●								Test Voltage	S-1
Blown Fuse		●								Test Voltage	S-4
Loose Connection		●								Check Wiring	S-2
Shorted or Broken Wires		●								Check Wiring	S-3A
No Low Voltage		●								Check Transformer	S-4
Faulty Thermostat		●			●	●		●	●	Check Thermostat	S-3A
Faulty Transformer		●								Check Transformer	S-4
Poor or High Resistance Ground				●						Measure Ground Resistance	S-17B
Improper Heat Anticipator Setting					●	●		●	●	Adjust Heat Anticipator Setting	S-3B
Improper Thermostat Location					●	●		●	●	Relocate Thermostat	S-316
Faulty Limit or Roll Out Switch			●	●						Test Control	S-300 / S-302
Faulty Flame Sensor				●						Test Flame Sensor	S-314
Faulty Ignition Control		●	●	●						Test Control	S-313
Gas Valve or Gas Supply Shut Off			●							Turn Valves to On Position	S-317
Faulty Induced Draft Blower			●				●			Test Induced Draft Motor	S-303
Faulty Blower Motor (PSC & ECM)			●	●						Test Blower Motor (PSC & ECM)	S-16A,B,C
Broken or Shorted Ignitor			●							Test Ignitor	S-308
Dirty Flame Sensor, Low UA				●						Clean Flame Sensor	S-314
Stuck Gas Valve			●				●	●		Replace Gas Valve	S-304
Faulty Gas Valve			●				●	●	●	Replace Gas Valve	S-304
Open Auxiliary Limit			●	●						Reset Control	S-301
Improper Air Flow or Distribution				●					●	Check Duct Static	S-200
Cycling on Limit				●	●				●	Check Controls & Temperature Rise	S-201 / S-300
Delayed Ignition							●			Test for Delayed Ignition	S-312
Flashback							●			Test for Flashback	S-309 / S-311
Orifice Size							●	●	●	Check Orifices	S-306 / S-311
Gas Pressure			●				●	●	●	Check Gas Pressure	S-307
Cracked Heat Exchanger							●			Check Burner Flames	S-305
Furnace Undersized						●			●	Replace with Proper Size Furnace	S-318
Furnace Oversized					●					Replace with Proper Size Furnace	S-318
Faulty Pressure Switch			●	●	●					Test Pressure Switch	S-310
Blocked or Restricted Flue							●			Check Flue/Drawdown Pressure	S-310
Open Roll Out Switch			●	●						Test Flame Roll Out Control	S-302
Bouncing On Pressure Switch				●						Test Negative Pressure	S-310



SERVICING

SERVICE NUMBERS

S-1	CHECKING VOLTAGE	99
S-2	CHECKING WIRING	99
S-3	CHECKING THERMOSTAT, WIRING, AND ANTICIPATOR	99
S-3A	Thermostat and Wiring	99
S-3B	Heating Anticipator	99
S-4	CHECKING TRANSFORMER AND CONTROL CIRCUIT	100
S-15	CHECKING CAPACITOR	101
S-15A	Resistance Check	101
S-16A	CHECKING AIR CIRCULATOR BLOWER MOTOR	101
S-200	CHECKING DUCT STATIC	113
S-201	CHECKING TEMPERATURE RISE	113
S-300	CHECKING PRIMARY LIMIT CONTROL	114
S-301	CHECKING AUXILIARY LIMIT CONTROL	115
S-302	CHECKING FLAME ROLLOUT CONTROL	117
S-303	TEST INDUCED DRAFT MOTOR	118
S-304	CHECKING GAS VALVE	118
S-305	CHECKING MAIN BURNERS	118
S-306	CHECKING ORIFICES	118
S-307	CHECKING GAS PRESSURE	119
S-308	CHECKING HOT SURFACE IGNITOR	122
S-309	CHECKING FOR FLASHBACK	123
S-310	CHECKING PRESSURE CONTROL	123
S-311	HIGH ALTITUDE APPLICATION (USA)	124
S-312	CHECKING FOR DELAYED IGNITION	124
S-313	CHECKING IGNITION CONTROL BOARDS	124
S-314	CHECKING FLAME SENSOR	128

SERVICING

S-1 CHECKING VOLTAGE

 WARNING	
HIGH VOLTAGE DISCONNECT ALL POWER BEFORE SERVICING OR CHANGING ANY ELECTRICAL WIRING. MULTIPLE POWER SOURCES MAY BE PRESENT. FAILURE TO DO SO MAY CAUSE PROPERTY DAMAGE, PERSONAL INJURY OR DEATH.	

1. Remove the burner door on 80% and 90% furnaces to gain entry to the Junction Box. Earlier designed 80% furnaces have the Junction Box located in the blower compartment.
2. Remove cover from the Junction Box and gain access to incoming power lines.

With Power ON:

 WARNING
LINE VOLTAGE NOW PRESENT

3. Using a voltmeter, measure the voltage across the hot and neutral connections.

NOTE: To energize the furnace, the Door Interlock Switch must be engaged at this point.

4. No reading - indicates open wiring, open fuse, no power, or faulty Door Interlock Switch. from unit to fused disconnect service. Repair as needed.
5. With ample voltage at line voltage connectors, energize the furnace blower motor by jumpering terminals R to G on the integrated ignition control.
6. With the blower motor in operation, the voltage should be 115 volts \pm 10 percent.
7. If the reading falls below the minimum voltage, check the line wire size. Long runs of undersized wire can cause low voltage. If wire size is adequate, notify the local power company of the condition.
8. After completing check and/or repair, replace Junction Box cover and reinstall the service panel doors.
9. Turn on electrical power and verify proper unit operation.

S-2 CHECKING WIRING

 WARNING
DISCONNECT ALL POWER BEFORE SERVICING.

1. Check wiring visually for signs of overheating, damaged insulation and loose connections.
2. Use an ohmmeter to check continuity of any suspected open wires.

3. If any wires must be replaced, replace with AWM, 105°C. 2/64 thick insulation of the same gauge or its equivalent.

CHECKING THERMOSTAT, WIRING AND ANTICIPATOR

S-3A THERMOSTAT AND WIRING

 WARNING
DISCONNECT ALL POWER BEFORE SERVICING.

1. Remove the blower compartment door to gain access to the thermostat low voltage wires located at the furnace integrated control module terminals.
2. Remove the thermostat low voltage wires at the furnace control panel terminal board.
3. Jumper terminals R to W (or W1 and W2 for two-stage models) on the integrated ignition control.

With Power On (and Door Interlock Switch closed):

 WARNING
LINE VOLTAGE NOW PRESENT

4. Induced Draft Motor must run and pull in pressure switch.
5. If the hot surface ignitor heats and at the end of the ignitor warm-up period the gas valve opens and the burners ignite, the trouble is in the thermostat or wiring.
6. With power off, check the continuity of the thermostat and wiring. Repair or replace as necessary.

If checking the furnace in the air conditioning mode, proceed as follows.

7. With power off, Jumper terminals R to Y (or Y1 or Y2 for two-stage models) to G.
8. Turn on the power.
9. If the furnace blower motor starts and the condensing unit runs, then the trouble is in the thermostat or wiring. Repair or replace as necessary.
10. After completing check and/or repair of wiring and check and/or replacement of thermostat, reinstall blower compartment door.
11. Turn on electrical power and verify proper unit operation.

S-3B HEATING ANTICIPATOR

The heating anticipator is a wire wound adjustable heater which is energized during the "ON" cycle to help prevent overheating of the conditioned space.

The anticipator is a part of the thermostat and if it should fail for any reason, the thermostat must be replaced.

SERVICING

The heating anticipator setting for furnaces covered in this manual is **0.70 Amps**.

If the anticipator current draw is unknown, then a current amp draw should be measured to determine the anticipator setting. Use an amprobe as shown in the following drawing.

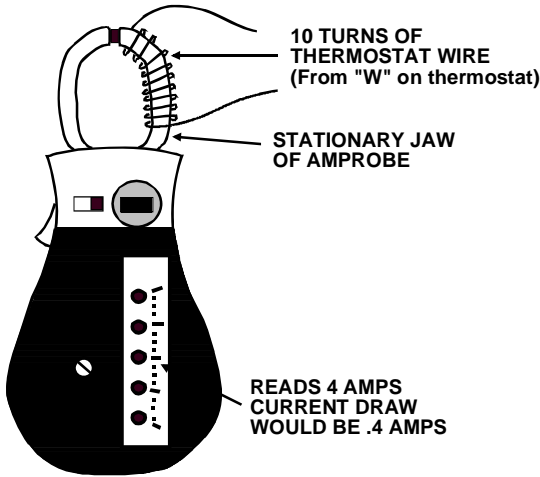

Checking Heating Anticipator Current (Amp) Draw

Cooling Anticipator

The cooling anticipator is a small heater (resistor) in the thermostat. During the "OFF" cycle it heats the bimetal element helping the thermostat call for the next cooling cycle. This prevents the room temperature from rising too high before the system is restarted. A properly sized anticipator should maintain room temperature within 1 1/2 to 2 degrees.

The anticipator is fixed in the subbase and is not to be replaced. If the anticipator should fail for any reason, the subbase must be changed.

S-4 CHECKING TRANSFORMER AND CONTROL CIRCUIT

A step-down transformer 120 volt primary to 24 volt secondary, 40 VA (Heating and Cooling Models) supplies ample capacity of power for either operation.

WARNING

HIGH VOLTAGE
DISCONNECT ALL POWER BEFORE SERVICING OR CHANGING ANY ELECTRICAL WIRING. MULTIPLE POWER SOURCES MAY BE PRESENT. FAILURE TO DO SO MAY CAUSE PROPERTY DAMAGE, PERSONAL INJURY OR DEATH.

1. Remove blower compartment door to gain access to the thermostat low voltage wires located at the furnace integrated control module.
2. Remove the thermostat low voltage wires at the furnace integrated control module terminals.

With Power On (and Door Interlock Switch closed):

WARNING

LINE VOLTAGE NOW PRESENT

3. Use a voltmeter, check voltage across terminals R and C. Must read 24 VAC.
4. No voltage indicates faulty transformer, open fuse, bad wiring, bad splice, or open door interlock switch.
5. Check transformer primary voltage at incoming line voltage connections, fuse, splices, and blower door interlock switch.
6. If line voltage is available to the primary side of transformer and not at secondary side, the transformer is inoperative. Replace.
7. After completing check and/or replacement of transformer and check and/or repair of control circuit, reinstall blower compartment door.
8. Turn on electrical power and verify proper unit operation.

S-10B Capacitance Check

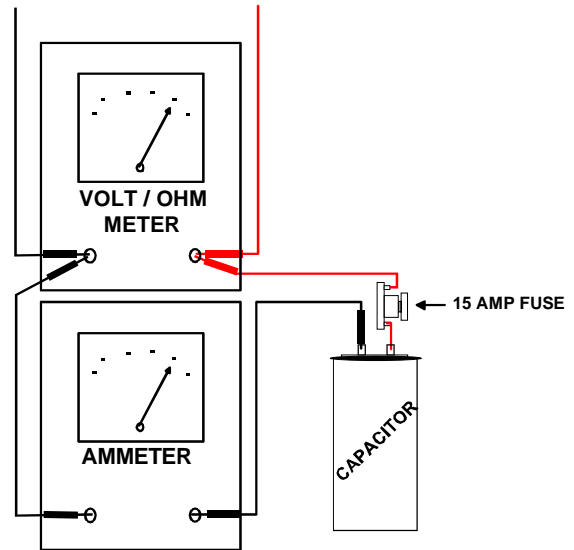

Testing Capacitance

With power On (and Door Interlock Switch closed):

WARNING

LINE VOLTAGE NOW PRESENT

Using a hookup as shown above, take the current and voltage readings and use them in the formula:

$$\text{Capacitance (MFD)} = 2650 \times \text{Current/Voltage}$$

4. After completing check and/or replacement of capacitor, reinstall blower compartment door.
5. Turn on electrical power and verify proper unit operation.

SERVICING

S-15 CHECKING CAPACITOR

The direct drive motors are of the permanent split capacitor design. A run capacitor is wired across the auxiliary and a portion of the main windings. The capacitor's primary function is to reduce the line current while greatly improving the torque characteristics of a motor. This is accomplished by using the 90° phase relationship between the capacitor current and voltage in conjunction with the motor windings so that the motor will give two phase operation when connected to a single phase circuit. The capacitor also reduces the line current to the motor by improving the power factor to the load.

 WARNING
DISCHARGE CAPACITOR THROUGH A 20 TO 30 OHM RESISTOR BEFORE HANDLING.

Two quick ways to test a capacitor are a resistance and a capacitance check. Refer to the next two figures for proper meter connections for the resistance and capacitance testing of the capacitor.

S-15A Resistance Check

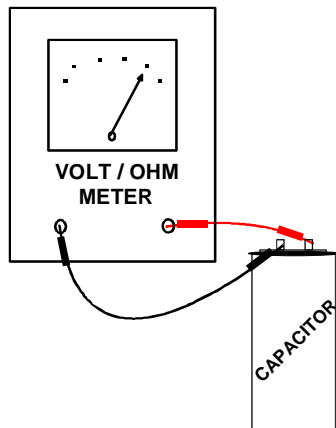

Testing Capacitor Resistance

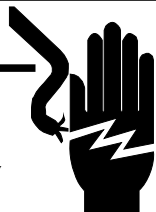
 WARNING	
HIGH VOLTAGE DISCONNECT ALL POWER BEFORE SERVICING OR INSTALLING THIS UNIT. MULTIPLE POWER SOURCES MAY BE PRESENT. FAILURE TO DO SO MAY CAUSE PROPERTY DAMAGE, PERSONAL INJURY OR DEATH.	

1. Remove blower compartment door to gain access to capacitor.
2. Discharge capacitor and remove wire leads.
3. Set an ohmmeter on its highest ohm scale and connect the leads to the capacitor.

- a. Good Condition - indicator swings to zero and slowly returns toward infinity.
- b. Shorted - indicator swings to zero and stops there - replace.
- c. Open - no reading - replace. Reverse leads. Check again no reading - replace.
- d. Reverse leads and recheck.

S-16A CHECKING AIR CIRCULATOR BLOWER MOTOR (PSC & ECM)

 WARNING
DISCONNECT ALL POWER BEFORE SERVICING.

1. Remove blower compartment door to gain access to the circulator blower motor and integrated ignition control.
2. Discharge the capacitor on (PSC) motors. Disconnect the motor wire leads from its connection point at the integrated ignition control module and capacitor if applicable.
3. Using an ohmmeter, test for continuity between each of the motor leads.
4. Touch one probe of the ohmmeter to the motor frame (ground) and the other probe in turn to each lead.

If the windings do not test continuous or a reading is obtained to ground, replace the motor.

5. After completing check and/or replacement of circulator blower motor or induced draft blower motor, reinstall blower compartment door.
6. Turn on electrical power and verify proper unit operation.

The 80% and 90% Two-Stage Variable Speed furnaces incorporate the GE® ICM or variable speed blower motors for greater efficiency. ECM/ICM motors vary the motor RPMs to provide a set volume of air over a wide range of conditions. These motors use an electronic control module attached to the motors end bell to control motor operation. Some unique features of these motors are:

1. Constant Airflow. These motors will maintain constant airflow over a wide static pressure range. In other words, as the static increases so does the motors RPM so that a constant CFM is maintained.

NOTE: The motor in these units will move more air under higher static conditions than a similar sized unit using a PSC motor. Because this motor does not load up and reduce airflow like a PSC motor, in some undersized duct installations this may cause noise or high airflow complaints.

2. Ramp-up/Ramp-down feature. These motors ramp up and down at the beginning or end of a cycle to reduce air rush noise.

SERVICING

3. High voltage is present at the motor all the time. Motor operation is controlled through the low voltage motor interface board that provides an output voltage to the motor end bell. This voltage output determines the CFM, which the motor will provide.

A Green LED light, located on the integrated ignition control, next to the fuse, indicates the airflow that the motor is supposed to be delivering. The number of blinks depends upon the positioning of the pin selector switches on the integrated ignition control. The number of blinks multiplied by 100 yields the programmed CFM (Example: 10 Blinks x 100 = 1000 CFM). The indicated CFM may vary, depending on the mode of operation and the signals being sent to the control board at the time.

ECM/ICM Control Connections

EMC/ICM control connections are made through the thermostat connections on the integrated ignition control. No other control connections are needed.

NOTE: An inductor (*Factor Power Choke Correction*) is required when powering the 3/4 and 1 horsepower motors with 115 volts (inductor pictured below). The operation of this inductor is to reduce the line current by storing the electrical energy in a magnetic field, such that the voltage AC waveform leads the current AC waveform. In other words, the inductor reduces line current which extends the life of the 3/4 and 1 horsepower motors. The furnaces requiring an inductor are shown in the following chart.

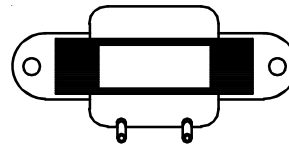

80% Models	90% Models	95% Models
*MV80704BXA	*CV90704CXA	GMV950704CXA
*MV90805CXA	*MV90704CXA	GMV950905DXA
*MV81155CXA	*CV90905DXA	GMV951155DXA
	*MV90905DXA	
	*MV91155DXA	

IMPORTANT: If the inductor fails, there will be no motor operation since this is the "LINE" power supply, black wire, from the integrated ignition control to the motor. To determine if the inductor is at fault, you can bypass by the inductor by disconnecting the black wire from the inductor and connecting it directly to the motor. If the motor operates then the inductor will need to be replaced.

Checking ECM/ICM Motors

ECM/ICM motors connect directly to the AC Line Voltage. **DO NOT** insert contactors in series with the ECM/ICM Motor AC Line. The control is powered continuously to insure reliable start-up. The connector plug is polarized, verify and reverify correct connector orientation before applying power. **DO NOT** force plug into motor and make sure power is off before inserting power connector. **DO NOT** apply voltage to terminals 1 or 2.

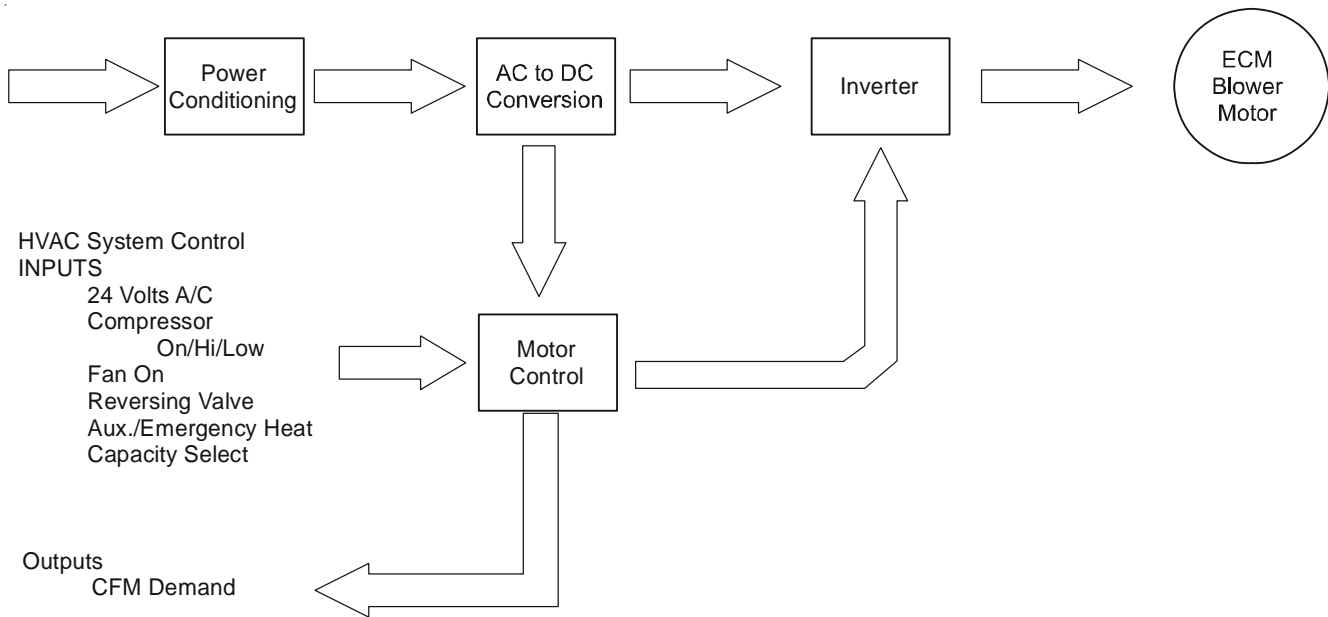

ECM/ICM CONTROL FLOW CHART

SERVICING



WARNING

LINE VOLTAGE NOW PRESENT

Check for line voltage on terminals 4 and 5. Verify terminal 3 is ground. Terminals 1 and 2 are jumpered in the harness for 120VAC operation.

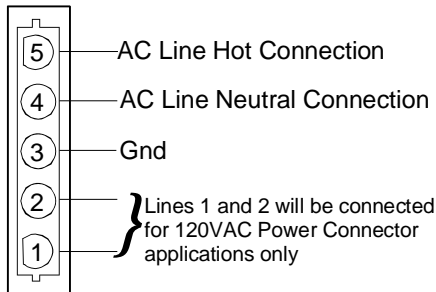

**POWER CONNECTOR
 (1/2 HP MOTORS)
 "Motor Half"
 (Viewed from Plug End)**

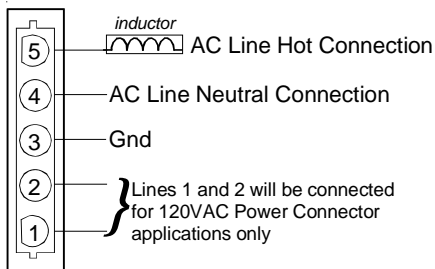

**POWER CONNECTOR
 (3/4 & 1 HP MOTORS)
 "Motor Half"
 (Viewed from Plug End)**

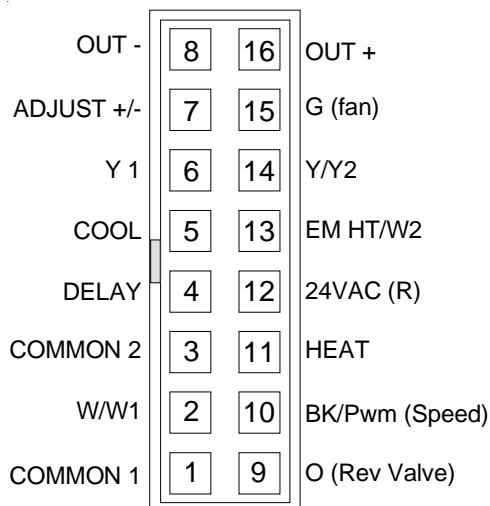

**CONTROL CONNECTOR
 "Motor Half"
 (Viewed from connector end)**



CAUTION

HIGH VOLTAGE ON CONTROL PINS WILL DESTROY MOTOR

Do not apply 24 volts to terminals "Out +" or "Out -".
 Make sure connector is fully seated.
 Make sure pins are fully seated in connector housing.
 Verify C1 and C2 are connected to transformer common.
 Verify "R" is connected to transformer hot.

After verifying above connections, motor can be tested by applying 24 volts to control pins. Example: R to G will cause the fan to come at "Fan-Only" CFM, R to G to Y will cause the fan to come on at cooling speed and R to G to W will cause the fan to come on at heating speed.

If motor does not respond as noted, ICM control unit is bad and should be replaced.

Replacing ICM Control Module

Use the following steps to replace the control module for the GE® variable speed indoor blower motor.

1. You must have the correct replacement module. The controls are factory programmed for specific operating modes. Even though they look alike, different modules may have completely different functionality. Using the wrong control module voids all product warranties and may produce unexpected results.
2. Remove all power from the unit being serviced. Do not work on the motor with power applied. Wait at least 5 minutes after disconnecting power from the equipment before opening the motor.
3. It is usually not necessary to remove the motor from the blower assembly. However it is recommended that the whole blower assembly, with the motor, be removed. Unplug the two cable connectors to the motor. There are latches on each connector. Do not pull on the wires. The plugs remove easily when properly released.
4. Locate the two standard 1/4" hex head bolts. Remove these bolts from the motor while holding the control module.
5. The control module is now free of the motor but still attached by a plug and cable. Carefully rotate the control so as to gain access to the plug on the end of the cable. Squeeze the release latch and gently pull the plug out of the control module. Do not pull on the wires. Grip the plug only.

SERVICING

6. The control module is now completely detached from the motor. Verify with a standard ohmmeter that the resistance from each motor lead (in the motor plug just removed) to the motor shell is greater than 100k ohms. (Measure resistance to unpainted motor end plate). If any motor lead fails this test do not proceed to install the control module. The motor is defective and must be replaced. Installing the new control module will cause it fail also.
7. Verify that the replacement control module is correct for your application. If so, orient the new module next to the motor and carefully insert the plug removed in step 5. Be sure the plug latches. It will click when properly inserted.
8. Install the new control module back on the motor being careful to engage the locating notches onto the appropriate mating tabs. Replace the two 1/4" hex head bolts. Tighten the bolts snugly. It is not necessary to over-tighten.

Note: Before replacing the blower/motor assembly, it is important to look at the installation to see if some application fault has caused the motor to fail.

Is there any evidence of water damage to the failed control? (Corrosion on the inside or outside of the casting.) If yes, do a moisture check.

9. Re-install the blower/motor assembly into the furnace.

10. Plug the 16-pin control plug into the motor. The plug is keyed. Make sure the connector is properly seated and latched.
11. Plug the 5 pin power connector into the motor even though the plug is keyed, observe the proper orientation. Do not force the connector. It plugs in very easily when properly oriented. **Reversing this plug will cause immediate failure of the control module.**
12. Final installation check. Make sure the motor is installed as follows:
 - a. As far into the blower housing as possible.
 - b. Belly bands not covering vent holes or on the control module.
 - c. Motor connectors should oriented as to prevent the accumulation of moisture in the control.
 - d. Use wire ties to create a drip loop in the motor cables.
13. The installation is now complete. Reapply power to the furnace and verify that the new motor control module is working properly.

For complete troubleshooting information on the variable speed air circulator blower motors, refer to the *Troubleshooting Chart for ECM/ICM Variable Speed Air Circulator Blower Motors* on the next page of this manual.

SERVICING

Troubleshooting Chart for ECM/ICM Variable Speed Air Circulator Blower Motors				
Symptoms of Abnormal Operation	Fault Description(s)	Possible Causes	Corrective Action	Cautions and Notes
- Motor rocks slightly when starting.	- This is normal start-up for variable speed motor.	----	----	----
- Motor won't start.	- No movement.	<ul style="list-style-type: none"> - Manual disconnect switch off or door switch open. - Blown fuse or circuit breaker. - 24 Vac wires miswired. - Unseated pins in wiring harness connectors. - Bad motor/control module. - Moisture present in motor or control module. 	<ul style="list-style-type: none"> - Check 115 Vac power at motor. - Check low voltage (24 Vac R to C) at motor. - Check low voltage connections (G, Y, W, R, C) at motor. - Check for unseated pins in connectors on motor harness. - Test with a temporary jumper between R - G. 	<ul style="list-style-type: none"> - Turn power OFF prior to repair. Wait 5 minutes after disconnecting power before opening motor. - Handle electronic motor/control with care.
- Motor oscillates up & down while being tested off of blower.	- Motor rocks, but won't start.	<ul style="list-style-type: none"> - Loose motor mount. - Blower wheel not tight on motor shaft. - Bad motor/control module. 	<ul style="list-style-type: none"> - Check for loose motor mount. - Make sure blower wheel is tight on shaft. - Perform motor/control replacement check, ICM-2 motors only. 	<ul style="list-style-type: none"> - Turn power OFF prior to repair. Wait 5 minutes after disconnecting power before opening motor. - Handle electronic motor/control with care.
- Motor starts, but runs erratically.	- It is normal for motor to oscillate with no load on shaft.	----	----	----
	- Varies up and down or intermittent.	<ul style="list-style-type: none"> - Variation in 115 Vac to motor. - Unseated pins in wiring harness connectors. - Erratic CFM command from "BK" terminal. - Improper thermostat connection or setting. - Moisture present in motor/control module. 	<ul style="list-style-type: none"> - Check line voltage for variation or "sag". - Check low voltage connections (G, Y, W, R, C) at motor, unseated pins in motor harness connectors. - Check-out system controls - Thermostat. - Perform Moisture Check.* 	<ul style="list-style-type: none"> - Turn power OFF prior to repair.
	- "Hunts" or "puffs" at high CFM (speed).	<ul style="list-style-type: none"> - Incorrect or dirty filter(s). - Incorrect supply or return ductwork. - Incorrect blower speed setting. 	<ul style="list-style-type: none"> - Does removing panel or filter reduce "puffing"? - Check/replace filter. - Check/correct duct restrictions. - Adjust to correct blower speed setting. 	<ul style="list-style-type: none"> - Turn power OFF prior to repair.

CHART CONTINUED ON NEXT PAGE

SERVICING

CHART CONTINUED FROM PREVIOUS PAGE

Troubleshooting Chart for ECM/ICM Variable Speed Air Circulator Blower Motors

Symptoms of Abnormal Operation	Fault Description(s)	Possible Causes	Corrective Action	Cautions and Notes
- Motor starts, but runs erratically.	- Stays at low CFM despite system call for cool or heat CFM.	- 24 Vac wires miswired or loose. - "R" missing/not connected at motor. - Fan is delay mode.	- Check low voltage (Thermostat) wires and connections. - Verify fan is not in delay mode - wait until delay complete. - Perform motor/control replacement check, ICM-2 motors only.	- Turn power OFF prior to repair. Wait 5 minutes after disconnecting power before opening motor. - Handle electronic motor/control with care.
	- Stays at high CFM.	- "R" missing/not connected at motor. - Fan is delay mode.	- Is fan in delay mode? - wait until delay time complete. - Perform motor/control replacement check, ICM-2 motors only.	- Turn power OFF prior to repair. Wait 5 minutes after disconnecting power before opening motor. - Handle electronic motor/control with care.
- Blower won't shut off.	- Blower won't shut off.	- Current leakage from controls into G, Y, or W.	- Check for Triac switched Tstat or solid state relay.	- Turn power OFF prior to repair.
	- Air noise.	- High static creating high blower speed. - Incorrect supply or return ductwork. - Incorrect or dirty filter(s). - Incorrect blower speed setting.	- Check/replace filter. - Check/correct duct restrictions. - Adjust to correct blower speed setting.	- Turn power OFF prior to repair.
	- Noisy blower or cabinet.	- Loose blower housing, panels, etc. - High static creating high blower speed. - Air leaks in ductwork, cabinets, or panels.	- Check for loose blower housing, panels, etc. - Check for air whistling thru seams in ducts, cabinets or panels. - Check for cabinet/duct deformation.	- Turn power OFF prior to repair.
- Excessive noise.	- "Hunts" or "puffs" at high CFM (speed).	- High static creating high blower speed. - Incorrect or dirty filter(s). - Incorrect supply or return ductwork. - Incorrect blower speed setting.	- Does removing panel or filter reduce "puffing"? - Check/replace filter. - Check/correct duct restrictions. - Adjust to correct blower speed setting.	- Turn power OFF prior to repair.
	- Motor failure or malfunction has occurred and moisture is present.	- Moisture in motor/control module.	- Replace motor and perform Moisture Check.*	- Turn power OFF prior to repair. Wait 5 minutes after disconnecting power before opening motor. - Handle electronic motor/control with care.
- Evidence of Moisture.	- Motor failure or malfunction has occurred and moisture is present.	- Moisture in motor/control module.	- Replace motor and perform Moisture Check.*	- Turn power OFF prior to repair. Wait 5 minutes after disconnecting power before opening motor. - Handle electronic motor/control with care.

*Moisture Check

- Connectors are oriented "down" (or as recommended by equipment manufacturer).
- Arrange harnesses with "drip loop" under motor.
- Is condensate drain plugged?
- Check for low airflow (too much latent capacity).
- Check for undercharged condition.
- Check and plug leaks in return ducts, cabinet.

NOTE: You must use the correct replacement control motor module since they are factory programmed for specific operating modes. Even though they look alike, different modules may have completely different functionality. The ICM-2 variable speed motors are currently the only motors that can have the motor/control module replaced.

IMPORTANT NOTE: Using the wrong motor/control module voids all product warranties and may produce unexpected results.

SERVICING

VARIABLE SPEED (ECM) MOTOR TEST (Low Stage Heat Call)

THERMOSTAT HEAT INPUT(S): R, W1

First, low voltage readings are measured with the 16-pin wire harness disconnected from the motor. A diagram of the harness and pin locations is provided below. Voltage measurement is AC or DC as specified in the chart below under the (Volts) column. Set your voltage meter to the proper AC or DC reading as requested below.

Thermostat Input(s): R, W1			
Description	Pin	Volts ⁽⁵⁾	Signal Indicates
Com, C1	1	0 VAC	Common
W/W1	2	≥ 13 VAC	W1 = ON
Com, C2	3	0 VAC	Common
Delay ⁽⁴⁾	4	0 VAC	Delay Tap = A
		≥ 10 VDC	Delay Tap = B
		≤ -10 VDC	Delay Tap = C
		24 VAC	Delay Tap = D
Cool ⁽⁴⁾	5	0 VAC	Cool Tap = A
		≥ 10 VDC	Cool Tap = B
		≤ -10 VDC	Cool Tap = C
		24 VAC	Cool Tap = D
Y1	6	0 VAC	Y1 = OFF
Adjust ⁽⁴⁾	7	0 VAC	Adjust Tap = A
		≥ 10 VDC	Adjust Tap = B
		≤ -10 VDC	Adjust Tap = C
		24 VAC	Adjust Tap = D
Out - ⁽³⁾	8	0 VDC	Common
O	9	0 VAC	O = OFF
Bk/PWM ⁽²⁾	10	24 VAC	No Dehumidification
Heat ⁽⁴⁾	11	0 VAC	Heat Tap = A
		≥ 10 VDC	Heat Tap = B
		≤ -10 VDC	Heat Tap = C
		24 VAC	Heat Tap = D
R	12	24 VAC	R = ON
EM/W2	13	0 VAC	EM/W2 = OFF
Y/Y2	14	0 VAC	Y/Y2 = OFF
G ⁽¹⁾	15	≥ 13 VAC	G = ON
Out + ⁽³⁾	16	0-3.5 VDC	CFM LED

ECM Motor Not Coming On

In order for the heating fan speed to operate, the integrated control board has to receive a low-stage (W1) call from the thermostat. The control board now starts the heat sequence, bringing on the burners. After the control board goes through its timing sequence, the following signals should be seen at the end of the 16 pin harness going to the motor while the burners are firing.

Unplug the 16-pin harness from the ECM motor. Set volt meter to read AC volts. Place your voltage meter on Pin 1(Common) and Pin 2 (W1), you should be reading 13 AC volts. Next, check between Pin 1 (Common) and Pin 12 (R), you should read 24 AC volts. Finally, check between Pin 1(Common) and Pin 15 (G), you should read 13 AC Volts.

You **MUST** have all of these low voltage readings before the ECM motor will come on. If you **DO NOT** have these readings you may have a 16-pin harness or integrated control board problem.

Make sure you have high voltage at the 5-pin connector going to the motor as discussed earlier.

We highly recommend using the GE TECMate XL™ or the GE TECMate PRO™ model ECM motor tester. This low cost test instrument will verify whether the motor itself is good.

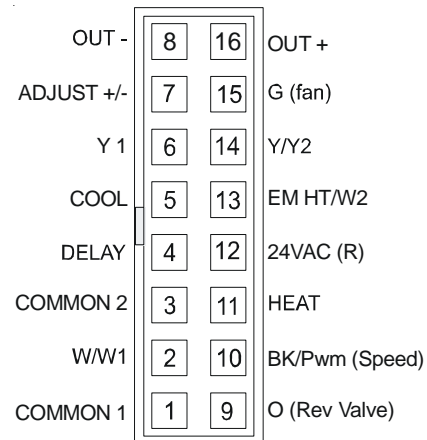

CONTROL CONNECTOR
"Motor Half"
(Viewed from connector end)

(1) This input must be active for motor to operate.

(2) 0 VAC indicates humidistat is calling for dehumidification.

(3) These two pins form an output circuit that powers the CFM LED on the ignition control or interface board.

(4) Dipswitch settings determine measure voltage.

(5) Voltage is measured with 16-wire harness disconnected from motor. Voltage measurement is AC or DC as specified in the chart.

SERVICING

VARIABLE SPEED (ECM) MOTOR TEST (High Stage Heat Call)

THERMOSTAT HEAT INPUT(S): R, W1, W2

First, low voltage readings are measured with the 16-pin wire harness disconnected from the motor. A diagram of the harness and pin locations is provided below. Voltage measurement is AC or DC as specified in the chart below under the (Volts) column. Set your voltage meter to the proper AC or DC reading as requested below.

Thermostat Input(s): R, W1, W2			
Description	Pin	Volts ⁽⁵⁾	Signal Indicates
Com, C1	1	0 VAC	Common
W/W1	2	≥ 13 VAC	W1 = ON
Com, C2	3	0 VAC	Common
Delay ⁽⁴⁾	4	0 VAC	Delay Tap = A
		≥ 10 VDC	Delay Tap = B
		≤ -10 VDC	Delay Tap = C
		24 VAC	Delay Tap = D
Cool ⁽⁴⁾	5	0 VAC	Cool Tap = A
		≥ 10 VDC	Cool Tap = B
		≤ -10 VDC	Cool Tap = C
		24 VAC	Cool Tap = D
Y1	6	0 VAC	Y1 = OFF
Adjust ⁽⁴⁾	7	0 VAC	Adjust Tap = A
		≥ 10 VDC	Adjust Tap = B
		≤ -10 VDC	Adjust Tap = C
		24 VAC	Adjust Tap = D
Out - ⁽³⁾	8	0 VDC	Common
O	9	0 VAC	O = OFF
Bk/PWM ⁽²⁾	10	24 VAC	No Dehumidification
Heat ⁽⁴⁾	11	0 VAC	Heat Tap = A
		≥ 10 VDC	Heat Tap = B
		≤ -10 VDC	Heat Tap = C
		24 VAC	Heat Tap = D
R	12	24 VAC	R = ON
EM/W2	13	24 VAC	EM/W2 = ON
Y/Y2	14	0 VAC	Y/Y2 = OFF
G ⁽¹⁾	15	≥ 13 VAC	G = ON
Out + ⁽³⁾	16	0-3.5 VDC	CFM LED

ECM Motor Not Coming On

In order for the heating fan speed to operate, the integrated control board has to receive a low-stage (W1) and (W2) call from the thermostat. The control board now starts the heat sequence, bringing on the burners. After the control board goes through its timing sequence, the following signals should be seen at the end of the 16 pin harness going to the motor while the burners are firing.

Unplug the 16-pin harness from the ECM motor. Set volt meter to read AC volts. Place your voltage meter on Pin 1(Common) and Pin 2 (W1), you should be reading 13 AC volts, if the (W2) is calling you should see 24 AC volts. Next, check between Pin 1 (Common) and Pin 12 (R), you should read 24 AC volts. Finally, check between Pin 1 (Common) and Pin 15 (G), you should read 13 AC Volts.

You **MUST** have all of these low voltage readings before the ECM motor will come on. If you **DO NOT** have these readings you may have a 16-pin wire harness or integrated control board problem.

Make sure you have high voltage at the 5-pin connector going to the motor as discussed earlier.

We highly recommend using the GE TECMate PRO™ model ECM motor tester. This low cost test instrument will verify whether the motor itself is good.

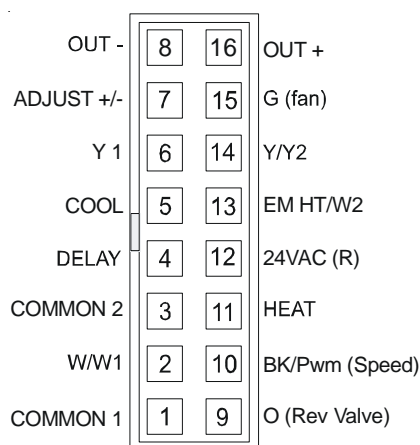

CONTROL CONNECTOR
"Motor Half"
(Viewed from connector end)

(1) This input must be active for motor to operate.

(2) 0 VAC indicates humidistat is calling for dehumidification.

(3) These two pins form an output circuit that powers the CFM LED on the ignition control or interface board.

(4) Dipswitch settings determine measure voltage.

(5) Voltage is measured with 16-wire harness disconnected from motor. Voltage measurement is AC or DC as specified in the chart.

SERVICING

VARIABLE SPEED (ECM) MOTOR TEST (Fan Only Call)

THERMOSTAT CONTINUOUS FAN INPUT(S):

R, G

First, low voltage readings are measured with the 16-pin wire harness disconnected from the motor. A diagram of the harness and pin locations is provided below. Voltage measurement is AC or DC as specified in the chart below under the (Volts) column. Set your voltage meter to the proper AC or DC reading as requested below.

Thermostat Input(s): R, G			
Description	Pin	Volts ⁽⁵⁾	Signal Indicates
Com, C1	1	0 VAC	Common
W/W1	2	0 VAC	W1 = OFF
Com, C2	3	0 VAC	Common
Delay ⁽⁴⁾	4	0 VAC	Delay Tap = A
		≥ 10 VDC	Delay Tap = B
		≤ -10 VDC	Delay Tap = C
		24 VAC	Delay Tap = D
Cool ⁽⁴⁾	5	0 VAC	Cool Tap = A
		≥ 10 VDC	Cool Tap = B
		≤ -10 VDC	Cool Tap = C
		24 VAC	Cool Tap = D
Y1	6	0 VAC	Y1 = OFF
Adjust ⁽⁴⁾	7	0 VAC	Adjust Tap = A
		≥ 10 VDC	Adjust Tap = B
		≤ -10 VDC	Adjust Tap = C
		24 VAC	Adjust Tap = D
Out - ⁽³⁾	8	0 VDC	Common
O	9	0 VAC	O = OFF
Bk/PWM ⁽²⁾	10	24 VAC	No Dehumidification
Heat ⁽⁴⁾	11	0 VAC	Heat Tap = A
		≥ 10 VDC	Heat Tap = B
		≤ -10 VDC	Heat Tap = C
		24 VAC	Heat Tap = D
R	12	24 VAC	R = ON
EM/W2	13	0 VAC	EM/W2 = OFF
Y/Y2	14	0 VAC	Y/Y2 = OFF
G ⁽¹⁾	15	≥ 13 VAC	G = ON
Out + ⁽³⁾	16	0-3.5 VDC	CFM LED

ECM Motor Not Coming On

In order for the continuous fan speed to operate, the integrated control board has to receive (G) signal from the thermostat. Turn the thermostat to the Fan On position. If the fan will not run, verify 24 volts on the integrated control boards low voltage terminal strip at (C) and (R) with your volt meter. If you have 24 volts, place a jumper wire between the (R) and (G) terminal on the control board. If the motor now operates then you have a problem in the thermostat cable from the thermostat or with the thermostat.

Unplug the 16-pin harness from the ECM motor. Set volt meter to read AC volts. Place your voltage meter on Pin 1(Common) and Pin 12 (R), you should read 24 AC volts. Finally, check between Pin 1(Common) and Pin 15 (G), you should read 13 AC Volts.

You MUST have all of these low voltage readings before the ECM motor will come on. If you DO NOT have these readings you may have a 16-pin wire harness or integrated control board problem.

Make sure you have high voltage at the 5-pin connector going to the motor as discussed earlier.

We highly recommend using the GE TECMate PRO™ model ECM motor tester. This low cost test instrument will verify whether the motor itself is good.

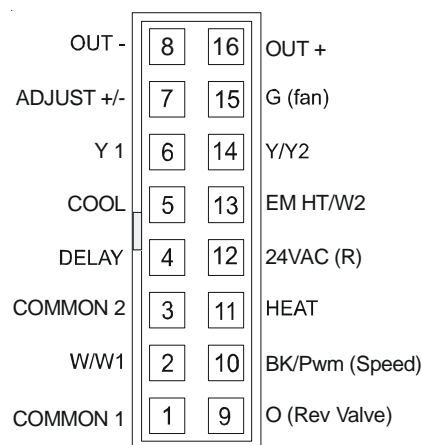

CONTROL CONNECTOR
"Motor Half"
(Viewed from connector end)

(1) This input must be active for motor to operate.

(2) 0 VAC indicates humidistat is calling for dehumidification.

(3) These two pins form an output circuit that powers the CFM LED on the ignition control or interface board.

(4) Dipswitch settings determine measure voltage.

(5) Voltage is measured with 16-wire harness disconnected from motor. Voltage measurement is AC or DC as specified in the chart.

SERVICING

VARIABLE SPEED (ECM) MOTOR TEST (Cooling Low-Stage Call)

THERMOSTAT LOW INPUT(S): R, Y1, G

First, low voltage readings are measured with the 16-pin wire harness disconnected from the motor. A diagram of the harness and pin locations is provided below. Voltage measurement is AC or DC as specified in the chart below under the (Volts) column. Set your voltage meter to the proper AC or DC reading as requested below.

Thermostat Input(s): R, Y1, G			
Description	Pin	Volts ⁽⁵⁾	Signal Indicates
Com, C1	1	0 VAC	Common
W/W1	2	0 VAC	W1 = OFF
Com, C2	3	0 VAC	Common
Delay ⁽⁴⁾	4	0 VAC	Delay Tap = A
		≥ 10 VDC	Delay Tap = B
		≤ -10 VDC	Delay Tap = C
		24 VAC	Delay Tap = D
Cool ⁽⁴⁾	5	0 VAC	Cool Tap = A
		≥ 10 VDC	Cool Tap = B
		≤ -10 VDC	Cool Tap = C
		24 VAC	Cool Tap = D
Y1	6	24 VAC	Y1 = ON
Adjust ⁽⁴⁾	7	0 VAC	Adjust Tap = A
		≥ 10 VDC	Adjust Tap = B
		≤ -10 VDC	Adjust Tap = C
		24 VAC	Adjust Tap = D
Out - ⁽³⁾	8	0 VDC	Common
O	9	0 VAC	O = OFF
Bk/PWM ⁽²⁾	10	24 VAC	No Dehumidification
Heat ⁽⁴⁾	11	0 VAC	Heat Tap = A
		≥ 10 VDC	Heat Tap = B
		≤ -10 VDC	Heat Tap = C
		24 VAC	Heat Tap = D
R	12	24 VAC	R = ON
EM/W2	13	0 VAC	EM/W2 = OFF
Y/Y2	14	0 VAC	Y/Y2 = OFF
G ⁽¹⁾	15	≥ 13 VAC	G = ON
Out + ⁽³⁾	16	0-3.5 VDC	CFM LED

ECM Motor Not Coming On

In order for the cooling fan speed to operate, the integrated control board has to receive (Y1) signal from the thermostat. Turn the thermostat to the Cooling 1st stage position. If the fan will not run, verify 24 volts on the integrated control boards low voltage terminal strip at (C) and (R) with your volt meter. If you have 24 volts, place a jumper wire between the (R), (YLO) and (G) terminal on the control board. If the motor now operates then you have a problem in the thermostat or thermostat cable. If the motor does not operate, check for high voltage at the 5-pin connector on the motor.

You should have approximately 120 volts all the time to the motor. Failure to receive power could be faulty harness, loose connection or faulty inductor.

Unplug the 16-pin harness from the ECM motor. Set volt meter to read AC volts. Place your voltage meter on Pin 1(Common) and Pin 12 (R), you should read 24 AC volts. Finally, check between Pin 1(Common) and Pin 15 (G), you should read 13 AC Volts. Next, check between Pin 1 (Common) and Pin 6 (Y1), you should read 24 AC volts.

You **MUST** have all of these low voltage readings before the ECM motor will come on. If you **DO NOT** have these readings you may have a 16-pin wire harness or integrated control board problem.

We highly recommend using the GE TECMate PRO™ model ECM motor tester. This low cost test instrument will verify whether the motor itself is good.

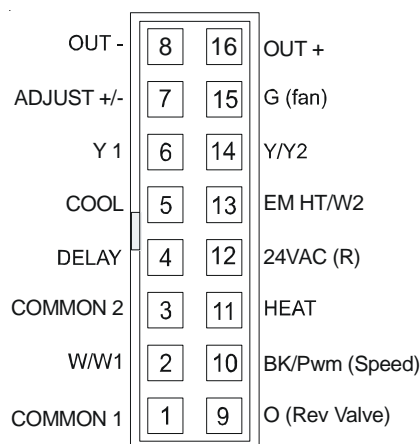

CONTROL CONNECTOR

"Motor Half"

(Viewed from connector end)

(1) This input must be active for motor to operate.

(2) 0 VAC indicates humidistat is calling for dehumidification.

(3) These two pins form an output circuit that powers the CFM LED on the ignition control or interface board.

(4) Dipswitch settings determine measure voltage.

(5) Voltage is measured with 16-wire harness disconnected from motor. Voltage measurement is AC or DC as specified in the chart.

SERVICING

VARIABLE SPEED (ECM) MOTOR TEST (Cooling Two-Stage Call)

THERMOSTAT HEAT INPUT(S): R, Y1, Y2, G

First, low voltage readings are measured with the 16-pin wire harness disconnected from the motor. A diagram of the harness and pin locations is provided below. Voltage measurement is AC or DC as specified in the chart below under the (Volts) column. Set your voltage meter to the proper AC or DC reading as requested below.

Thermostat Input(s): R, Y1, Y2, G			
Description	Pin	Volts ⁽⁵⁾	Signal Indicates
Com, C1	1	0 VAC	Common
W/W1	2	0 VAC	W1 = OFF
Com, C2	3	0 VAC	Common
Delay ⁽⁴⁾	4	0 VAC	Delay Tap = A
		≥ 10 VDC	Delay Tap = B
		≤ -10 VDC	Delay Tap = C
		24 VAC	Delay Tap = D
Cool ⁽⁴⁾	5	0 VAC	Cool Tap = A
		≥ 10 VDC	Cool Tap = B
		≤ -10 VDC	Cool Tap = C
		24 VAC	Cool Tap = D
Y1	6	24 VAC	Y1 = ON
Adjust ⁽⁴⁾	7	0 VAC	Adjust Tap = A
		≥ 10 VDC	Adjust Tap = B
		≤ -10 VDC	Adjust Tap = C
		24 VAC	Adjust Tap = D
Out - ⁽³⁾	8	0 VDC	Common
O	9	0 VAC	O = OFF
Bk/PWM ⁽²⁾	10	24 VAC	No Dehumidification
Heat ⁽⁴⁾	11	0 VAC	Heat Tap = A
		≥ 10 VDC	Heat Tap = B
		≤ -10 VDC	Heat Tap = C
		24 VAC	Heat Tap = D
R	12	24 VAC	R = ON
EM/W2	13	0 VAC	EM/W2 = OFF
Y/Y2	14	24 VAC	Y/Y2 = ON
G ⁽¹⁾	15	≥ 13 VAC	G = ON
Out + ⁽³⁾	16	0-3.5 VDC	CFM LED

ECM Motor Not Coming On

In order for the cooling fan speed to operate, the integrated control board has to receive a (Y1) and (Y2) signal from the thermostat. Turn the thermostat to the Cooling two-stage position. If the fan will not run, verify 24 volts on the integrated control boards low voltage terminal strip at (C) and (R) with your volt meter. If you have 24 volts, remove thermostat wires from the integrated control boards terminal strip. Now place a jumper wire between the (R), (Y1), (Y2) and (G) terminal on the control board. If the motor now operates then you have a problem in the thermostat or thermostat cable. If the motor does not operate, with the terminals above jumped out, unplug the 16-pin harness from the ECM motor. Set volt meter to read AC volts. Place your voltage meter on Pin 1 (Common) and Pin 12 (R) should read 24 AC volts, Pin 1 (Common) and Pin 6 (Y1) and to Pin 14 (Y/Y2) should read 24 AC volts. Finally, check between Pin 1 (Common) and Pin 15 (G), you should read 13 AC volts.

You **MUST** have all of these low voltage readings before the ECM motor will come on. If you **DO NOT** have these readings you may have a 16-pin wire harness or integrated control board problem.

Make sure you have high voltage at the 5-pin connector going to the motor as discussed earlier.

We highly recommend using the GE TECMate PRO™ model ECM motor tester. This low cost test instrument will verify whether the motor itself is good.

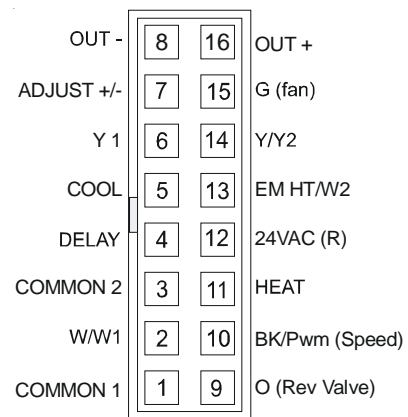

**CONTROL CONNECTOR
"Motor Half"
(Viewed from connector end)**

(1) This input must be active for motor to operate.

(2) 0 VAC indicates humidistat is calling for dehumidification.

(3) These two pins form an output circuit that powers the CFM LED on the ignition control or interface board.

(4) Dipswitch settings determine measure voltage.

(5) Voltage is measured with 16-wire harness disconnected from motor. Voltage measurement is AC or DC as specified in the chart.

SERVICING

VARIABLE SPEED (ECM) MOTOR TEST (Heat Pump Cooling Single-Stage Call)

THERMOSTAT HEAT INPUT(S): R, Y1, O, G

First, low voltage readings are measured with the 16-pin wire harness disconnected from the motor. A diagram of the harness and pin locations is provided below. Voltage measurement is AC or DC as specified in the chart below under the (Volts) column. Set your voltage meter to the proper AC or DC reading as requested below.

Thermostat Input(s): R, Y1, O, G			
Description	Pin	Volts ⁽⁵⁾	Signal Indicates
Com, C1	1	0 VAC	Common
W/W1	2	0 VAC	W1 = OFF
Com, C2	3	0 VAC	Common
Delay ⁽⁴⁾	4	0 VAC	Delay Tap = A
		≥ 10 VDC	Delay Tap = B
		≤ -10 VDC	Delay Tap = C
		24 VAC	Delay Tap = D
Cool ⁽⁴⁾	5	0 VAC	Cool Tap = A
		≥ 10 VDC	Cool Tap = B
		≤ -10 VDC	Cool Tap = C
		24 VAC	Cool Tap = D
Y1	6	24 VAC	Y1 = ON
Adjust ⁽⁴⁾	7	0 VAC	Adjust Tap = A
		≥ 10 VDC	Adjust Tap = B
		≤ -10 VDC	Adjust Tap = C
		24 VAC	Adjust Tap = D
Out - ⁽³⁾	8	0 VDC	Common
O	9	24 VAC	O = ON
Bk/PWM ⁽²⁾	10	24 VAC	No Dehumidification
Heat ⁽⁴⁾	11	0 VAC	Heat Tap = A
		≥ 10 VDC	Heat Tap = B
		≤ -10 VDC	Heat Tap = C
		24 VAC	Heat Tap = D
R	12	24 VAC	R = ON
EM/W2	13	0 VAC	EM/W2 = OFF
Y/Y2	14	0 VAC	Y/Y2 = OFF
G ⁽¹⁾	15	≥ 13 VAC	G = ON
Out + ⁽³⁾	16	0-3.5 VDC	CFM LED

ECM Motor Not Coming On

In order for the cooling fan speed to operate with a heat pump, the integrated control board has to receive a (Y1) and (O) signal from the thermostat. Turn the thermostat to the Cooling position. If the fan will not run, verify 24 volts on the integrated control boards low voltage terminal strip at (C) and (R) with your volt meter. If you have 24 volts, remove thermostat wires from the integrated control boards terminal bar. Now place a jumper wire between the (R), (Y1), (O) and (G) terminal on the control board. If the motor now operates then you have a problem in the thermostat or thermostat cable. If the motor does not operate, with the terminals above jumped out, unplug the 16-pin harness from the ECM motor. Set volt meter to read AC volts. Place your voltage meter on Pin 1(Common) and Pin 12 (R) should read 24 AC volts, Pin 1(Common) and Pin 6 (Y1) or to Pin 9 (O) should read 24 AC volts. Finally, check between Pin 1(Common) and Pin 15 (G), you should read 13 AC volts.

You **MUST** have all of these low voltage readings before the ECM motor will come on. If you **DO NOT** have these readings you may have a 16-pin wire harness or integrated control board problem.

Make sure you have high voltage at the 5-pin connector going to the motor as discussed earlier.

We highly recommend using the GE TECMate PRO™ model ECM motor tester. This low cost test instrument will verify whether the motor itself is good.

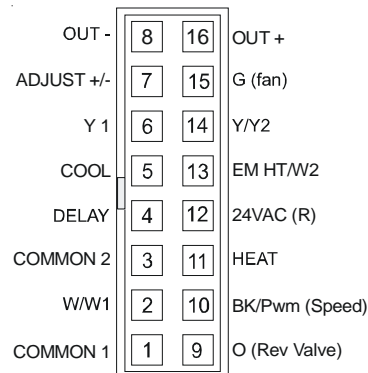

CONTROL CONNECTOR
"Motor Half"
(Viewed from connector end)

(1) This input must be active for motor to operate.

(2) 0 VAC indicates humidistat is calling for dehumidification.

(3) These two pins form an output circuit that powers the CFM LED on the ignition control or interface board.

(4) Dipswitch settings determine measure voltage.

(5) Voltage is measured with 16-wire harness disconnected from motor. Voltage measurement is AC or DC as specified in the chart.

SERVICING

S-200 CHECKING DUCT STATIC

The maximum and minimum allowable external static pressures are found in the specification section. These tables also show the amount of air being delivered at a given static by a given motor speed or pulley adjustment.

The furnace motor cannot deliver proper air quantities (CFM) against statics other than those listed.

Too great of an external static pressure will result in insufficient air that can cause excessive temperature rise, resulting in limit tripping, etc. Whereas not enough static may result in motor overloading.

To determine proper air movement, proceed as follows:

1. With clean filters in the furnace, use a draft gauge (inclined manometer) to measure the static pressure of the return duct at the inlet of the furnace. (Negative Pressure)
2. Measure the static pressure of the supply duct. (Positive Pressure)
3. Add the two (2) readings together for total external static pressure.

NOTE: Both readings may be taken simultaneously and read directly on the manometer if so desired. If an air conditioner coil or Electronic Air Cleaner is used in conjunction with the furnace, the readings must also include these components, as shown in the following drawing.

4. Consult proper tables for the quantity of air.

If the total external static pressure exceeds the minimum or maximum allowable statics, check for closed dampers, registers, undersized and/or oversized poorly laid out duct work.

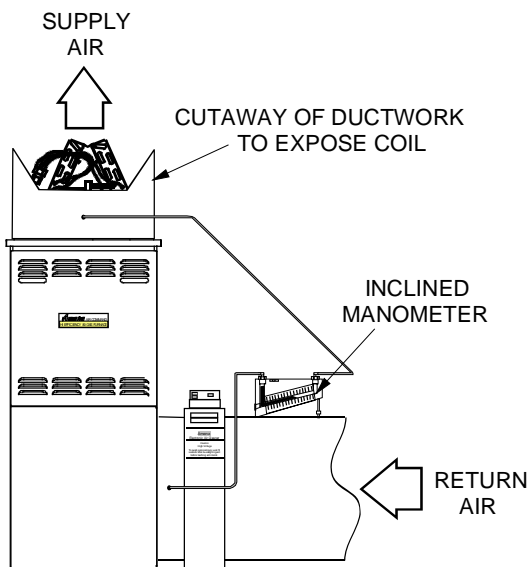

**Checking Static Pressure
(80% Furnace Shown, 90% Similar)**

S-201 CHECKING TEMPERATURE RISE

The more air (CFM) being delivered through a given furnace, the less the rise will be; so the less air (CFM) being delivered, the greater the rise. The temperature rise should be adjusted in accordance to a given furnace specifications and its external static pressure. An incorrect temperature rise may result in condensing in or overheating of the heat exchanger. An airflow and temperature rise table is provided in the blower performance specification section. Determine and adjust temperature rise as follows:

1. Operate furnace with burners firing for approximately ten minutes. Check BTU input to furnace - do not exceed input rating stamped on rating plate. Ensure all registers are open and all duct dampers are in their final (fully or partially open) position.
2. Place thermometers in the return and supply ducts as close to the furnace as possible. Thermometers must not be influenced by radiant heat by being able to "see" the heat exchanger.

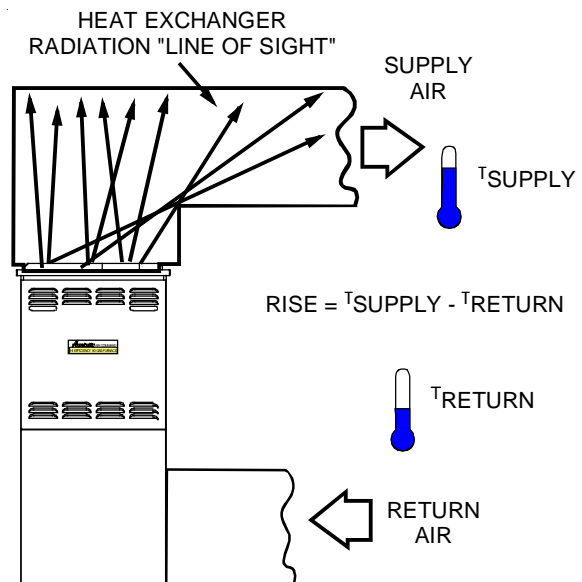

**Checking Temperature Rise
(80% Furnace Shown, 90% Similar)**

3. Subtract the return air temperature from the supply air temperature to determine the air temperature rise. Allow adequate time for thermometer readings to stabilize.
4. Adjust temperature rise by adjusting the circulator blower speed. Increase blower speed to reduce temperature rise. Decrease blower speed to increase temperature rise. Refer to *Circulator Blower Speed* section in the Product Design section of this manual for speed changing details. Temperature rise is related to the BTUH output of the furnace and the amount of air (CFM) circulated over the heat exchanger. Measure motor current draw to determine that the motor is not overloaded during adjustments.

SERVICING

S-300 CHECKING PRIMARY LIMIT CONTROL

All 80% and 90% furnaces use a nonadjustable, automatic reset, bi-metal type limit control. Refer to the following drawing for the location of the primary limit.

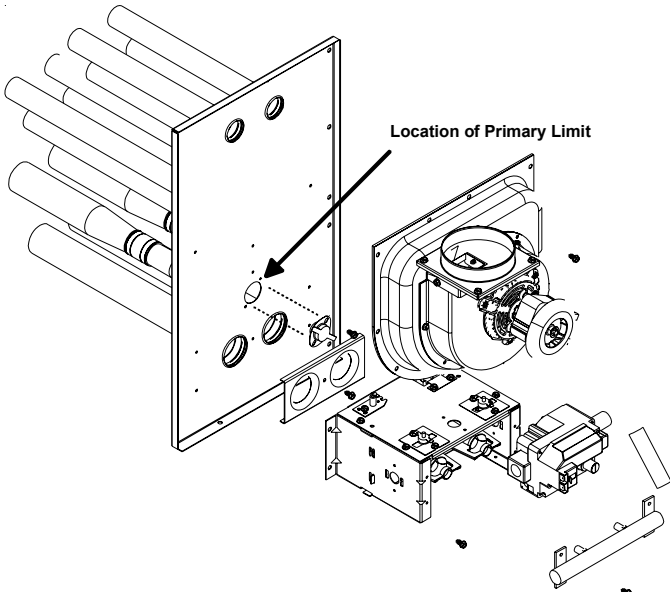

Primary Limit Control Location
(80% Upflow Furnace Shown, Counterflow Similar)

Style 1 drawing illustrates the Primary Limit used on the 80% furnaces.

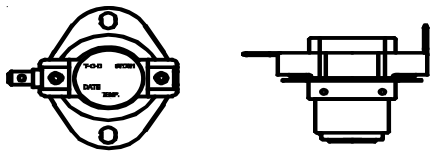

Style 1

All 90% furnaces use a nonadjustable, automatic reset, bi-metal type limit control. Refer to the following drawing for location of the primary limit on the 90% furnaces.

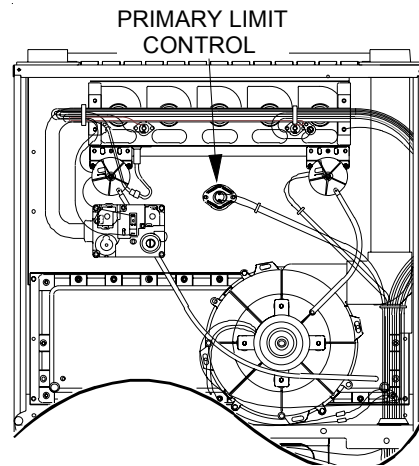

Primary Limit Control Location
(90% Upflow Furnace Shown, Counterflow Similar)

The following drawing illustrates the style of limit switches used on the 90% furnaces.

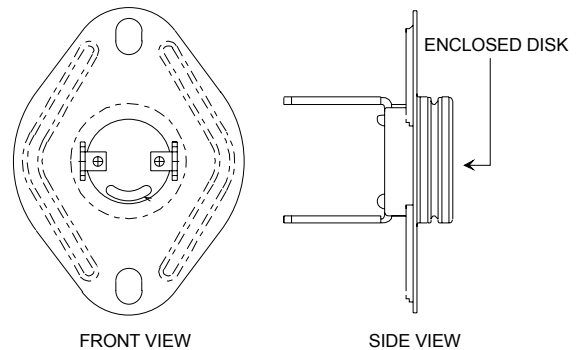

Primary Limit Control Style
(90% Furnaces)

⚠ WARNING

HIGH VOLTAGE
DISCONNECT ALL POWER BEFORE SERVICING OR CHANGING ANY ELECTRICAL WIRING. MULTIPLE POWER SOURCES MAY BE PRESENT. FAILURE TO DO SO MAY CAUSE PROPERTY DAMAGE, PERSONAL INJURY OR DEATH.

1. Remove burner compartment door to gain access to the primary limit.
2. Remove low voltage wires at limit control terminals.
3. With an ohmmeter, test between these two terminals as shown in the following drawing. The ohmmeter should read continuous unless heat exchanger temperature is above limit control setting. If not as above, replace the control.

SERVICING

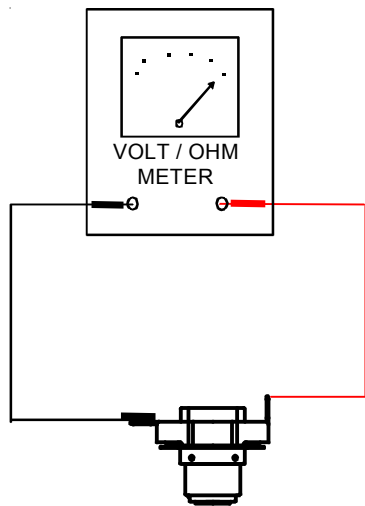

**Testing Primary Limit Control
(80% Furnaces)**

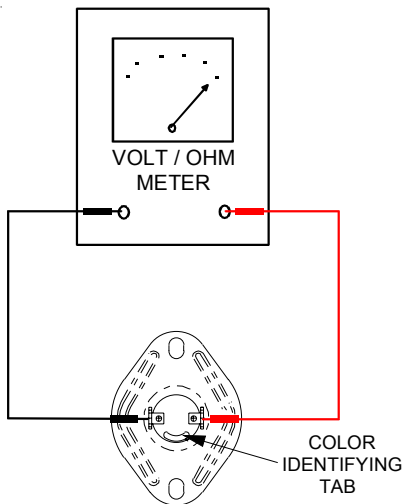

**Testing Primary Limit Control
(90% Furnaces)**

4. After completing check and/or replacement of primary limit control, reinstall burner compartment door.
5. Turn on electrical power and verify proper unit operation.

To aid in identifying these controls, refer to the *Primary Limit Charts* in furnace Technical Manual for part number, temperature setting and color(s) code.

S-301 CHECKING AUXILIARY LIMIT CONTROL

The **80% single stage** furnaces use a auxiliary limit (automatic reset) control connected in series with the gas valve and integrated control module. If its temperature should be exceeded, it will open, interrupting the voltage to the gas valve causing it to close. The auxiliary limit is located on the front side of the blower housing, near the center, on all 80% single-stage furnaces, as shown in the following illustration.

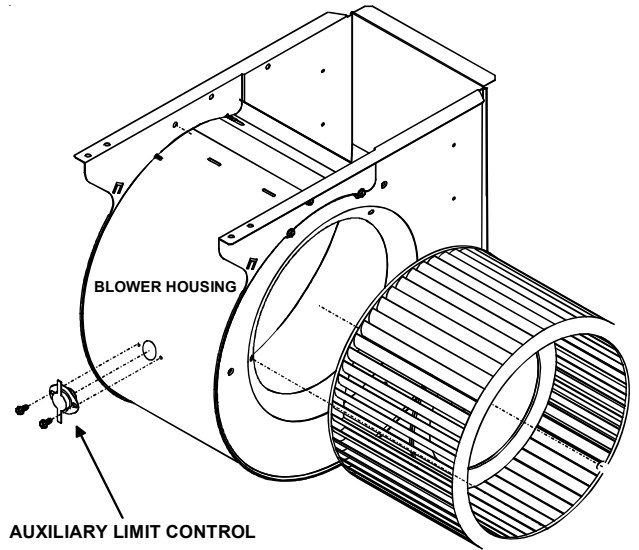

**Auxiliary Limit Control Location
(All 80% Single-Stage Furnaces)**

All **90% single-stage** upflow furnaces use one auxiliary limit switch for control of high temperatures within the furnace or duct work. This control is preset, nonadjustable and must be manually reset. The control is located in the blower compartment of the furnace on the blower deck, as shown in the following illustration.

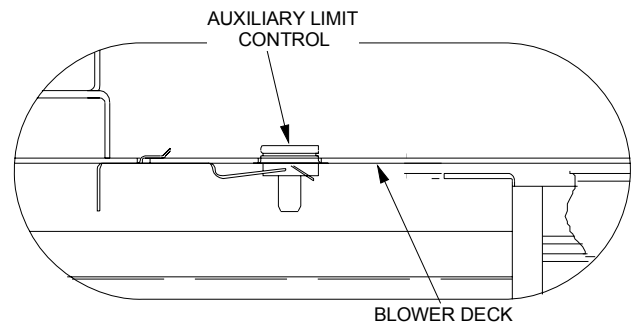

**Auxiliary Limit Control Location
(All 90% Single-Stage Furnaces)**

All 80% and 90% two-stage furnaces and 90% single-stage counterflow furnaces, use (2) two auxiliary limits located on the blower housing (one on each side), as shown in the following illustration.

SERVICING

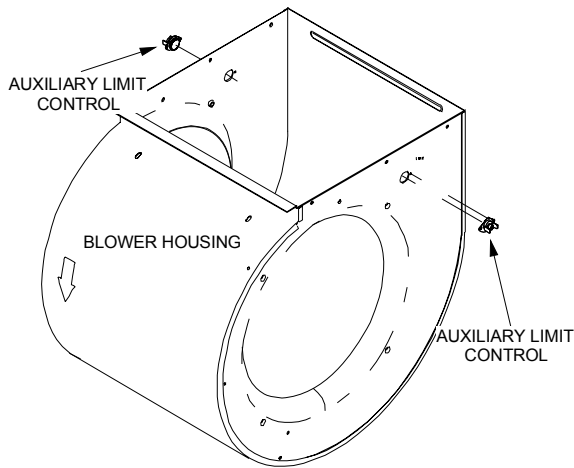

**Auxiliary Limit Control Location
(80 % and 90% Two-Stage Furnaces)**

The **80% two-stage** furnaces auxiliary limit control (automatic reset) is connected in series with the gas valve and the integrated ignition control. If its temperature should be exceeded, it will open, interrupting the voltage to the gas valve causing it to close.

If the auxiliary limit control opens, the air circulation blower will run continuously and the diagnostic light will flash (1) one time.

The auxiliary limit control is designed to prevent furnace operation in case of main blower failure in horizontal or counterflow installations. It may also open if the power supply is interrupted while the furnace is firing.

The auxiliary limit control is suitable for both horizontal right and horizontal left installations. Regardless of airflow direction, it does not need to be relocated.

The **90% two-stage and single-stage counterflow** furnaces auxiliary limit control (manual reset) is connected in series with the primary limit control wiring to the integrated ignition control. If its temperature should be exceeded, it will open, interrupting the voltage to the gas valve causing it to close.

If this limit control opens, the air circulation blower will run continuously and the diagnostic light will flash (4) four times. These symptoms are identical to a trip of the primary limit control.

The auxiliary limit control is designed to prevent furnace operation in case of main blower failure in horizontal or counterflow installations. It may also open if the power supply is interrupted while the furnace is firing.

The auxiliary limit control is suitable for both horizontal right and horizontal left installations. Regardless of airflow direction, it does not need to be relocated.

WARNING

HIGH VOLTAGE
DISCONNECT ALL POWER BEFORE SERVICING OR INSTALLING THIS UNIT. MULTIPLE POWER SOURCES MAY BE PRESENT. FAILURE TO DO SO MAY CAUSE PROPERTY DAMAGE, PERSONAL INJURY OR DEATH.

1. Remove blower compartment door to gain access to the auxiliary limit control which is located on the front of the blower housing on all 80% single-stage furnaces and on the blower deck of the 90% single-stage upflow furnaces. The two-stage 80% and 90% furnaces and 90% single-stage counterflow furnaces have (2) auxiliary limits, one located on each side of the blower housing.
2. Remove the wires from the auxiliary limit control terminals.
3. Using an ohmmeter, test for continuity across the two terminals (refer to the following auxiliary limit control figure). No reading indicates the control is open. Push red manual reset button (only on 90% furnaces), test again - if still open, replace the control.

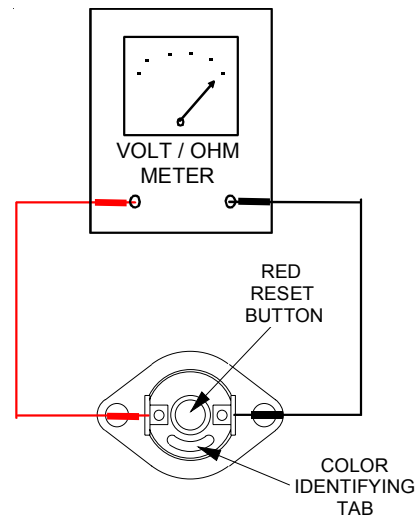

**Testing Auxiliary Limit Control
(80% & 90% Furnaces)**

WARNING

TO AVOID POSSIBLE FIRE, ONLY RESET THE AUXILIARY LIMIT CONTROL ONCE. IF IT SHOULD OPEN A SECOND TIME, A QUALIFIED SERVICER MUST DETERMINE WHY THE AUXILIARY LIMIT OPENED BEFORE RESETTING AGAIN.

NOTE: If it becomes necessary to slide the blower assembly out of any 90% single-stage upflow furnace, the auxiliary limit control must be removed from the blower deck before the blower assembly can be removed. After the blower assembly is reinstalled, the auxiliary limit must be reinstalled.

SERVICING

To aid in identifying these controls, color coded labels are attached to the back of the controls. Refer to the *Auxiliary Limit Charts* in furnace Technical Manual for color codes and temperature settings.

S-302 CHECKING FLAME ROLLOUT CONTROL

A temperature activated manual reset control is mounted to the manifold assembly on 80% & 90% furnaces, as shown in the following illustrations.

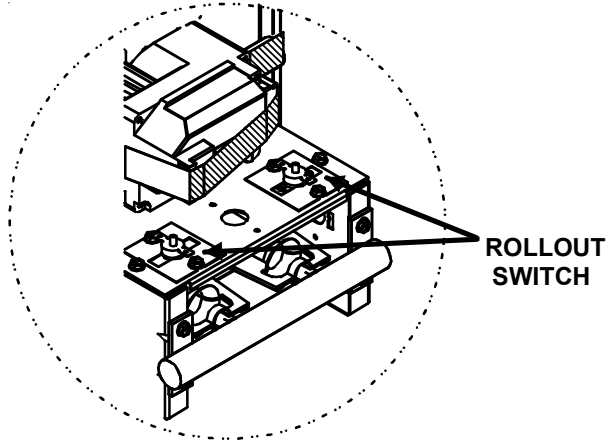

**Flame Rollout Switch Location
(80% Upflow Furnace Shown, Downflow Similar)**

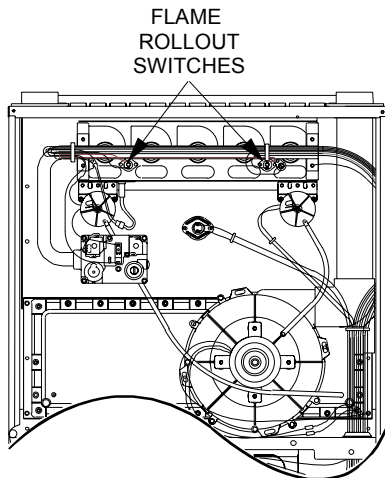

**Flame Rollout Switch Location
(90% Upflow Furnace Shown, Counterflow Similar)**

The control is designed to open should a flame roll out occur. An over firing condition or flame impingement on the heat shield may also cause the control to open. If the rollout control opens, the air circulation blower will run continuously.

On single-stage 80% and 90% models, the ignition control diagnostic light will flash (6) six times indicating a trip of the rollout switch.

On two-stage 80% and 90% models the ignition control the diagnostic light will flash (4) four times indicating a trip of the rollout switch. These symptoms are identical to a trip of the primary limit control.

To aid in identifying these controls, color coded labels have been affixed to the back of these controls. Refer to the *Rollout Limit Charts* in furnace Technical Manual for temperature settings and color codes.

The circuit between the ignition control and gas valve will be interrupted when the rollout switch opens up.



1. Remove the burner compartment door to gain access to the rollout switch(es) mounted to burner bracket.

The servicer should reset the ignition control by opening and closing the thermostat circuit. Then look for the ignitor glowing which indicates there is power to the ignition control. Measure the voltage between each side of the rollout control and ground while the ignition control tries to power the gas valve.

2. Measure the voltage between each side of the rollout control and ground during the ignition attempt. Refer to the following figure.

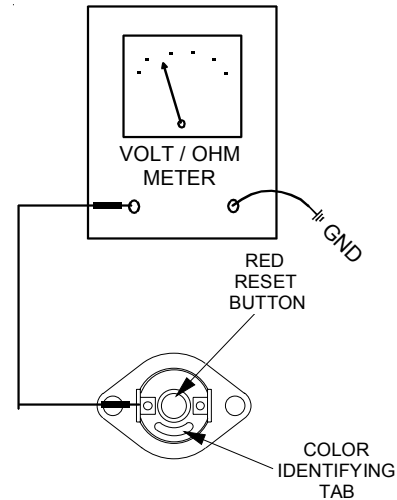



**Checking Flame Rollout Switch
(80% & 90% Furnaces)**

- a. If no voltage is measured on either side of control it indicates ignition control or wiring to control problem.
 - b. If voltage is measured on one side of the control and not the other it indicates the control is open.
 - c. If voltage is measured on both sides of the control the wiring to gas valve or valve is at fault.
3. After check and/or replacement of rollout switch, reinstall burner compartment door and verify proper unit operation.

SERVICING

S-303 INDUCED DRAFT BLOWER MOTOR

 WARNING	
HIGH VOLTAGE Disconnect ALL power before servicing or installing this unit. Multiple power sources may be present. Failure to do so may cause property damage, personal injury or death.	

1. Remove burner compartment door to gain access to the induced draft blower motor.
2. Disconnect the motor wire leads from its connection point at the induced draft motor.
3. Using an ohmmeter, test for continuity between each of the motor leads.
4. Touch one probe of the ohmmeter to the motor frame (ground) and the other probe in turn to each lead.
If the windings do not test continuous or a reading is obtained to ground, replace the motor.
5. If the windings have a continuity reading, reconnect wires. Turn power on to the furnace and turn the thermostat on in the heating mode. Check voltage for 115V at the induced draft motor terminals during the trial for ignition. If you have 115V and the motor does not run, replace the induced draft motor.
6. After completing check and/or replacement of induced draft motor, reinstall burner compartment door.
7. Turn on electrical power and verify proper unit operation.

S-304 CHECKING GAS VALVE (Redundant)

A combination redundant operator type gas valve which provides all manual and automatic control functions required for gas fired heating equipment is used.

The valve provides control of main burner gas flow, pressure regulation, and 100 percent safety shut-off.

 WARNING
Disconnect ALL power before servicing

Resistance of the redundant and 2nd stage coils on White-Rodgers 36E, 36F and 36G series gas valves can't be measured at the valve terminals with an ohmmeter because of diodes. The on/off switch may effect the resistance measurement.

1. Using an ohmmeter, test across the coils. A coil's resistance increases with increasing temperature.

Nominal Coil Resistance:

Main = 95 ohms

Redundant = 98 ohms

2nd Stage = 180 ohms

2. Allow at least 20% tolerance for temperature and meter variation. Most of the time coils will fail as open circuit.

If not as above, replace the entire valve.

S-305 CHECKING MAIN BURNERS

The main burners are used to provide complete combustion of various fuels in a limited space, and transfer this heat of the burning process to the heat exchanger.

Proper ignition, combustion, and extinction are primarily due to burner design, orifice sizing, gas pressure, primary and secondary air, vent and proper seating of burners.

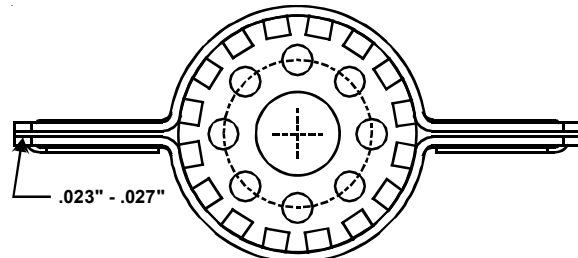

Beckett Burner

 WARNING
Disconnect ALL gas and electrical power supply.

In checking main burners, look for signs of rust, oversized and undersized carry over ports restricted with foreign material, etc, refer to previous drawing.

S-306 CHECKING ORIFICES

A predetermined fixed gas orifice is used in all of these furnaces. That is an orifice which has a fixed bore and position as shown in the following drawing.

No resizing should be attempted until all factors are taken into consideration such as inlet and manifold gas pressure, alignment, and positioning, specific gravity and BTU content of the gas being consumed.

The only time resizing is required is when a reduction in firing rate is required for an increase in altitude.

Orifices should be treated with care in order to prevent damage. They should be removed and installed with a box-end wrench in order to prevent distortion. In no instance should an orifice be peened over and redrilled. This will change the angle or deflection of the vacuum effect or entraining of primary air, which will make it difficult to adjust the flame properly. This same problem can occur if an orifice spud of a different length is substituted.

 WARNING
Disconnect ALL gas and electrical power supply.

1. Check orifice visually for distortion and/or burrs.
2. Check orifice size with orifice sizing drills.
3. If resizing is required, a new orifice of the same physical size and angle with proper drill size opening should be installed.

SERVICING

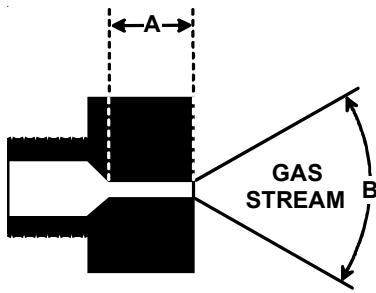

The length of Dimension "A" determines the angle of Gas Stream "B".

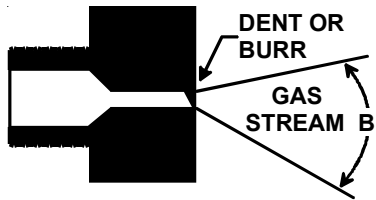

A dent or burr will cause a severe deflection of the gas stream.

S-307 CHECKING GAS PRESSURE

Gas Supply Pressure Measurement



CAUTION

TO PREVENT UNRELIABLE OPERATION OR EQUIPMENT DAMAGE, THE INLET GAS SUPPLY PRESSURE MUST BE AS SPECIFIED ON THE UNIT RATING PLATE WITH ALL OTHER HOUSEHOLD GAS FIRED APPLIANCES OPERATING.

Gas inlet and manifold pressures should be checked and adjusted in accordance to the type of fuel being consumed.

The line pressure supplied to the gas valve must be within the range specified below. The supply pressure can be measured at the gas valve inlet pressure tap or at a hose fitting installed in the gas piping drip leg. The supply pressure must be measured with the burners operating. To measure the gas supply pressure, use the following procedure.



WARNING

DISCONNECT ELECTRICAL POWER AND SHUT OFF GAS SUPPLY.

1. After turning off gas to furnace at the manual gas shutoff valve external to the furnace, remove burner compartment door to gain access to the gas valve.
2. Connect a calibrated water manometer (or appropriate gas pressure gauge) at either the gas valve inlet pressure tap or the gas piping drip leg as shown in the following figures.

NOTE: At either location, a hose fitting must be installed prior to making the hose connection.

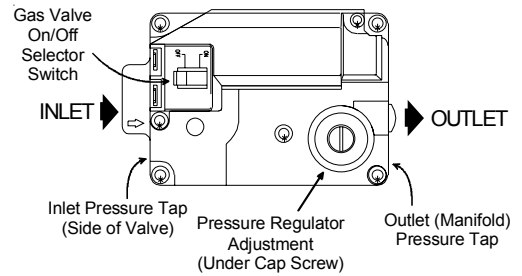

White-Rodgers Model 36F22

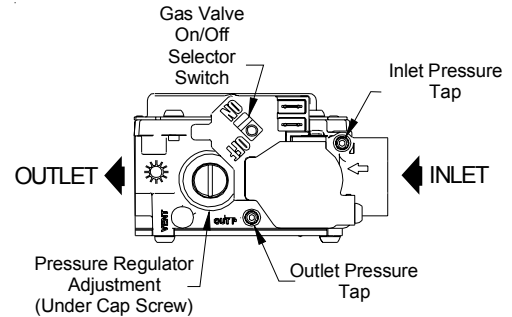

White-Rodgers Model 36G22

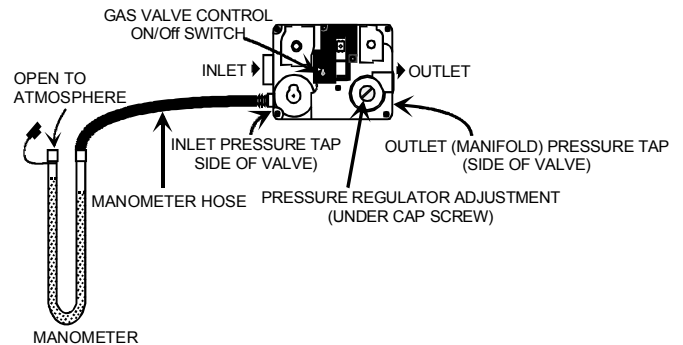

**Measuring Inlet Gas Pressure
White Rodgers 36E
(Gas Valve Tap)**

SERVICING

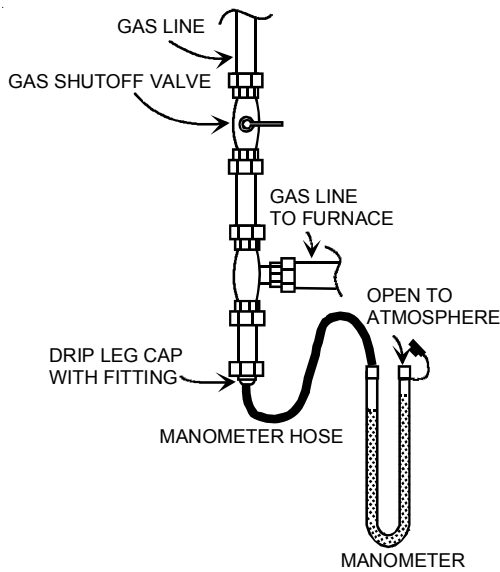

**Measuring Inlet Gas Pressure
(Alternate Method)**

3. Turn ON the gas and electrical power supply and operate the furnace and all other gas consuming appliances on the same gas supply line.
4. Measure furnace gas supply pressure with burners firing. Supply pressure must be within the range specified in the following table.

Inlet Gas Supply Pressure	
Natural Gas	Minimum: 5.0" W.C. Maximum :10.0" W.C.
Propane Gas	Minimum: 11.0" W.C. Maximum :13.0" W.C.

If supply pressure differs from above, make necessary adjustments to pressure regulator, gas piping size, etc., and/or consult with local gas utility.

WARNING

HIGH VOLTAGE
 DISCONNECT ALL ELECTRICAL POWER AND SHUT OFF GAS SUPPLY BEFORE SERVICING OR INSTALLING THIS UNIT.
 MULTIPLE POWER SOURCES MAY BE PRESENT. FAILURE TO DO SO MAY CAUSE PROPERTY DAMAGE, PERSONAL INJURY OR DEATH.

5. Disconnect manometer after turning off gas at manual shutoff valve. Reinstall plug before turning on gas to furnace.
6. Turn OFF any unnecessary gas appliances started in step 3.
7. Turn on gas to furnace and check for leaks. If leaks are found, repair and then reinstall burner compartment door.
8. Turn on electrical power and verify proper unit operation.

Gas Manifold Pressure Measurement and Adjustment (80% & 90% Single-Stage Furnaces)

CAUTION

TO PREVENT UNRELIABLE OPERATION OR EQUIPMENT DAMAGE, THE GAS MANIFOLD PRESSURE MUST BE AS SPECIFIED ON THE UNIT RATING PLATE. ONLY MINOR ADJUSTMENTS SHOULD BE MADE BY ADJUSTING THE GAS VALVE PRESSURE REGULATOR.

The gas pressure applies to line pressure as well and is easily checked on the White Rodgers 36G Valve with adapter kit # 0151K00000S.

Only small variations in gas pressure should be made by adjusting the gas valve pressure regulator. The manifold pressure must be measured with the burners operating. To measure and adjust the manifold pressure, use the following procedure.

WARNING

HIGH VOLTAGE
 DISCONNECT ALL ELECTRICAL POWER AND SHUT OFF GAS SUPPLY BEFORE SERVICING OR INSTALLING.

1. After turning off gas to furnace at the manual gas shutoff valve external to the furnace, remove burner compartment door to gain access to the gas valve.
2. Connect a calibrated water manometer (or appropriate gas pressure gauge) at the gas valve outlet pressure tap as shown in the following figure.

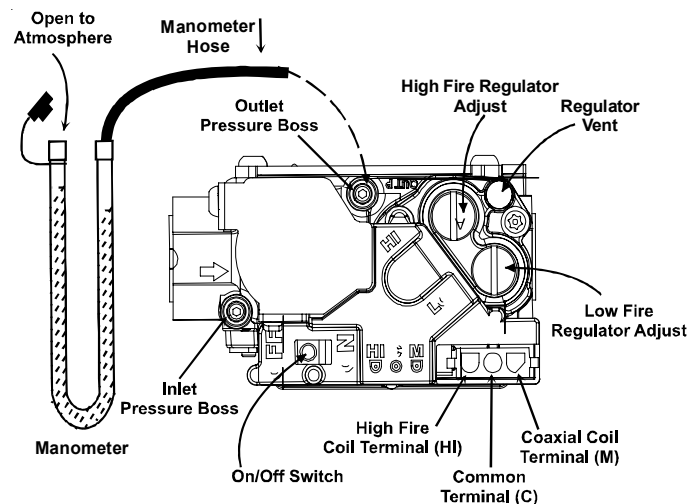

**Measuring Manifold Gas Pressure
(36G54 Valve)**

SERVICING



 WARNING
LINE VOLTAGE NOW PRESENT

- Turn ON the gas and electrical power supply and operate the furnace.
- Measure gas manifold pressure with burners firing. Adjust manifold pressure using the table below.

Manifold Gas Pressure	
Natural Gas	3.5" w.c.
Propane Gas	10.0" w.c.

The final manifold pressure must not vary more than ± 0.3 " w.c. from the above specified pressures. Any necessary major changes in gas flow rate should be made by changing the size of the burner orifice.

- To adjust the gas valve pressure regulator, remove the regulator cap.
- Turn the adjustment screw clockwise to increase the pressure, or counterclockwise to decrease the pressure.
- Securely replace the regulator cap.

 WARNING	
HIGH VOLTAGE	
DISCONNECT ALL ELECTRICAL POWER AND SHUT OFF GAS SUPPLY BEFORE SERVICING OR INSTALLING THIS UNIT.	
MULTIPLE POWER SOURCES MAY BE PRESENT. FAILURE TO DO SO MAY CAUSE PROPERTY DAMAGE, PERSONAL INJURY OR DEATH.	

- Disconnect manometer after turning off gas at manual shutoff valve. Reinstall gas valve outlet pressure tap plug before turning on gas to furnace.
- Turn on gas to furnace and check for leaks. If leaks are found, repair and then reinstall burner compartment door.
- Turn on electrical power and verify proper unit operation.

Gas Manifold Pressure Measurement and Adjustment (80% & 90% Two-Stage Furnaces)

Natural Gas Adjustments

 WARNING
HIGH VOLTAGE
DISCONNECT ALL ELECTRICAL POWER AND SHUT OFF GAS SUPPLY BEFORE SERVICING OR INSTALLING.

- After turning off gas to furnace at the manual gas shutoff valve external to the furnace, remove burner compartment door to gain access to the gas valve.

- Connect a calibrated water manometer (or appropriate gas pressure gauge) at the gas valve outlet pressure tap. Refer to previous *Measuring Manifold Gas Pressure* figure for proper connection.

 WARNING
LINE VOLTAGE NOW PRESENT

- Turn ON the gas and electrical power supply and operate the furnace.
- Remove the cap screw from the *high* stage manifold pressure regulator.
- Using a 3/32" Allen wrench, adjust the *high* stage manifold pressure regulator to the required pressure setting.
- Reinstall *high* stage cap screw and recheck manifold pressure setting with cap on.
- Remove the cap screw from the *low* stage manifold pressure regulator.
- Using a 3/32" Allen wrench, adjust the *low* stage regulator to the required pressure setting.
- Reinstall *low* stage cap screw and recheck manifold pressure setting with cap on.



 WARNING
HIGH VOLTAGE
DISCONNECT ALL ELECTRICAL POWER AND SHUT OFF GAS SUPPLY BEFORE SERVICING OR INSTALLING.

- Disconnect manometer after turning off gas at manual shutoff valve. Reinstall gas valve outlet pressure tap plug before turning on gas to furnace.
- Turn on gas to furnace and check for leaks. If leaks are found, repair and then reinstall burner compartment door.
- Turn on electrical power and verify proper unit operation. Make sure furnace operates at the proper manifold pressure at both high and low stage outputs.

Manifold Gas Pressure			
Gas	Rate	Range	Nominal
Natural Gas	High Stage	3.2 to 3.8" w.c.	3.5" w.c.
	Low Stage	1.6 to 2.2" w.c.	1.9" w.c.

SERVICING

Propane Gas Adjustments

 WARNING	
HIGH VOLTAGE DISCONNECT ALL ELECTRICAL POWER AND SHUT OFF GAS SUPPLY BEFORE SERVICING OR INSTALLING THIS UNIT. MULTIPLE POWER SOURCES MAY BE PRESENT. FAILURE TO DO SO MAY CAUSE PROPERTY DAMAGE, PERSONAL INJURY OR DEATH.	

1. After turning off gas to furnace at the manual gas shutoff valve external to the furnace, remove burner compartment door to gain access to the gas valve.
2. Connect a calibrated water manometer (or appropriate gas pressure gauge) at the gas valve outlet pressure tap. Refer to previous *Measuring Manifold Gas Pressure* figure for proper connection.

 WARNING
LINE VOLTAGE NOW PRESENT

3. Turn ON the gas and electrical power supply and operate the furnace.
4. Remove the cap screw from the *low* stage manifold pressure regulator.
5. Using a 3/32" Allen wrench, increase low fire manifold pressure by adjusting the *low* stage manifold regulator so the furnace will light and carryover.
6. Remove the cap screw from the *high* stage manifold pressure regulator adjustment location.
7. Using a 3/32" Allen wrench, adjust the *high* stage manifold pressure regulator to the required manifold pressure.
8. Reinstall *high* stage manifold regulator cap screw. Recheck manifold pressure setting with cap on.
9. Using a 3/32" Allen wrench, adjust the *low* stage manifold pressure regulator to the required manifold pressure.
10. Reinstall *low* stage manifold cap screw and recheck manifold pressure setting with cap on.

 WARNING
HIGH VOLTAGE DISCONNECT ALL ELECTRICAL POWER AND SHUT OFF GAS SUPPLY BEFORE SERVICING OR INSTALLING.

11. Disconnect manometer after turning off gas at manual shutoff valve. Reinstall gas valve outlet pressure tap plug before turning on gas to furnace.
12. Turn on gas to furnace and check for leaks. If leaks are found, repair and then reinstall burner compartment door.

13. Turn on electrical power and verify proper unit operation. Make sure furnace operates at the proper manifold pressure at both high and low stage outputs.

Manifold Gas Pressure			
Gas	Rate	Range	Nominal
Propane Gas	High Stage	9.7 to 10.3" w.c.	10.0" w.c.
	Low Stage	5.7 to 6.3" w.c.	6.0" w.c.

S-308 CHECKING HOT SURFACE IGNITOR

Goodman® and Amana® Distinctions™ Brand 80% and 90% furnaces use a 120V carbide mini igniter for ignition. The normal operating temperature is approximately 2550°F - 2876°F.

Amana® brand 80% and 90% furnaces use a 80V Silicon Nitride (SiNi) igniter for ignition. The nominal operating temperature is approximately 2174°F. **NOTE:** The *Silicon Nitride Ignitor* is not interchangeable with carbide ignition controls.

 WARNING
DISCONNECT ALL POWER BEFORE SERVICING.

1. Remove burner compartment door to gain access to the ignitor.
2. Ignitor cool - approximately 70 - 77°F.
3. Disconnect the ignitor from the Ignition Control.
4. Using an ohmmeter measure the resistance of the ignitor:

Goodman® and Amana® Distinctions™ Brand - 80% and 90% furnaces: Carbide Mini Igniter should read between 30 to 300 ohms.

Amana® Brand - 80% and 90% furnaces: Nitride Igniter should read between 10.9 to 19.7 ohms.
5. Reconnect ignitor.

 WARNING
LINE VOLTAGE NOW PRESENT

6. Place unit in heating cycle, measure current draw of ignitor during preheat cycle.

Goodman® and Amana® Distinctions™ Brand - 80% and 90% furnaces:

 Should read approximately 1 amp maximum. The steady state current at 120V is a nominal of .7 plus or minus .3 amps.

SERVICING

Amana® Brand - 80% and 90% furnaces: Should read approximately 1 to 3 amps. **NOTE:** Due to the "Adaptive Igniter Modulation Routine" of the integrated ignition control, the current reading will fluctuate when reading with a standard amp meter.

- After checking and/or replacing of hot surface ignitor, reinstall burner compartment door and verify proper unit operation.

S-309 CHECKING FOR FLASHBACK

Flashback will also cause burning in the burner venturi, but is caused by the burning speed being greater than the gas-air flow velocity coming from a burner port.

Flashback may occur at the moment of ignition, after a burner heats up or when the burner turns off. The latter is known as extinction pop.

Since the end results of flashback and delayed ignition can be the same (burning in the burner venturi) a definite attempt should be made to determine which has occurred.

If flashback should occur, check for the following:

- Improper gas pressure - adjust to proper pressure (See S-307 CHECKING GAS PRESSURE)..
- Check burner for proper alignment and/or replace burner.
- Improper orifice size - check orifice for obstruction.

S-310 CHECKING PRESSURE CONTROL

The pressure control is a safety device to prevent the combustion cycle from occurring with inadequate venting caused by a restricted or blocked vent pipe on the 80% and 90% furnaces. Also on the 90% furnaces there is a pressure control that will prevent the combustion cycle from occurring with inadequate condensate drainage due to a partial or blocked recuperator coil or drain.

 **WARNING**

HIGH VOLTAGE
DISCONNECT ALL POWER BEFORE SERVICING OR INSTALLING THIS UNIT. MULTIPLE POWER SOURCES MAY BE PRESENT. FAILURE TO DO SO MAY CAUSE PROPERTY DAMAGE, PERSONAL INJURY OR DEATH.



- Remove burner compartment door to gain access to pressure switch(es).
- Remove wires from the pressure switch(es) electrical terminals.
- Using a VOM check from common terminal to NC (Normally Closed) - should read open.

If switch reads as above proceed to Step 4, otherwise replace control.

- Remove the pressure control hose from the control and interconnect with an inclined manometer as shown in the following figures.

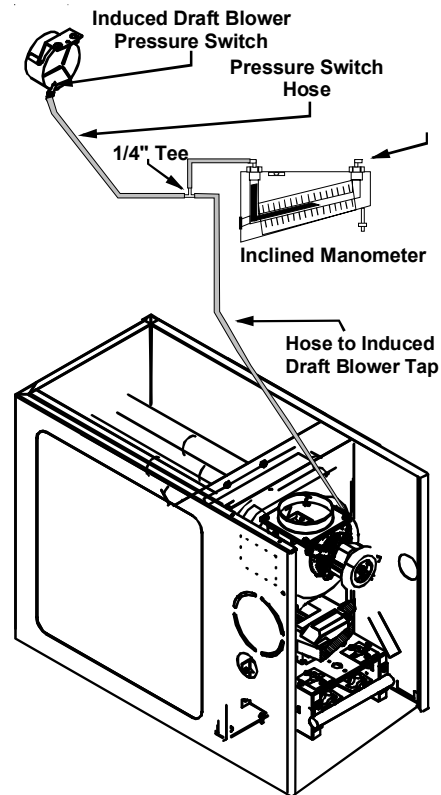

**ID Blower Pressure Switch
Negative Pressure Measurement
(80% Upflow Single-Stage Furnace Shown,
Counterflow Similar)**

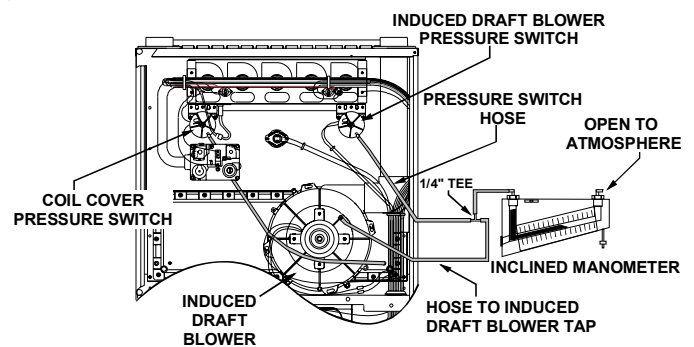

**Blower Pressure Switch
Negative Pressure Measurement
(90% Upflow Furnace Shown, Counterflow Similar)**

SERVICING

S-311 HIGH ALTITUDE APPLICATION (USA)

When these furnaces are installed at high altitude, the appropriate High Altitude Orifice or Pressure Switch Kit must be applied. This is required due to the natural reduction in the density of both the gas fuel and combustion air as altitude increases. The High Altitude Orifice Kit will provide the proper design certified input rate within the specified altitude range.

High Altitude Orifice or Pressure Switch Kits are purchased according to the installation altitude and usage of either natural or propane gas. Refer to the Technical Manual or product Specification Sheet for a tabular listing of appropriate altitude ranges and corresponding manufacturer's high altitude (Natural or Propane Gas) orifice or pressure switch kits.

Do **not** derate the furnace by adjusting the manifold pressure to a lower pressure than specified on the furnace rating plate. The combination of the lower air density and a lower manifold pressure will prohibit the burner orifice from drawing the proper amount of air into the burner. This may cause incomplete combustion, flashback, and possible yellow tipping.

In some areas the gas supplier may artificially derate the gas in an effort to compensate for the effects of altitude. If the gas is artificially derated the appropriate orifice size must be determined based on the BTU/ft³ content of the derated gas and the altitude. Refer to the National Fuel Gas Code, NFPA 54/ANSI Z223.1, and information provided by the gas supplier to determine the proper orifice size.

S-312 CHECKING FOR DELAYED IGNITION

Delayed ignition is a delay in lighting a combustible mixture of gas and air which has accumulated in the combustion chamber.

When the mixture does ignite, it may explode and/or rollout causing burning in the burner venturi.

If delayed ignition should occur, the following should be checked:

1. Improper gas pressure - adjust to proper pressure (See S-307 CHECKING GAS PRESSURE).
2. Improper burner positioning - burners should be in locating slots, level front to rear and left to right.
3. Carry over (lighter tube or cross lighter) obstructed - clean.
4. Main burner orifice(s) deformed, or out of alignment to burner - replace.

S-313 CHECKING INTEGRATED IGNITION CONTROL BOARDS

NOTE: A poor earth ground, floating ground, or high resistance neutral line will significantly shorten the life of the Silicon Nitride (SiNi) igniter used in Amana® brand 80% and 90% furnaces.

This section discusses various integrated ignition boards used on models listed in this manual. You will be guided through some common diagnostic procedures.

NOTE: Failure to earth ground the furnace, reversing the neutral and hot wire connection to the line (polarity), or a high resistance connection in the neutral line may cause the control to lockout due to failure to sense flame.

WARNING

TO AVOID THE RISK OF ELECTRICAL SHOCK, WIRING TO THE UNIT MUST BE PROPERLY POLARIZED AND GROUNDED. DISCONNECT POWER BEFORE PERFORMING SERVICE LISTED BELOW.

The ground wire must run from the furnace all the way back to the electrical panel. Proper grounding can be confirmed by disconnecting the electrical power and measuring resistance between the neutral (white) connection and the burner closest to the flame sensor. Resistance should be less than 10 ohms.

The ignition control is a combination electronic and electro-mechanical device and is not field repairable. Complete unit must be replaced.

WARNING

LINE VOLTAGE NOW PRESENT

These tests must be completed within a given time frame due to the operation of the ignition control.

The ignition control is capable of diagnosing many furnace failures to help in troubleshooting. A flashing red or green diagnostic indicator light on the control flashes a code for any detected failures.

When the control is powered up normally the light will be on continuously. This can be used to test for 120 volts and 24 volts to the control since both must be present for the light to be on. If this step fails, check for 120 volts to the control and check the transformer and its associated wiring. If this step is successful give the control a call for heat and wait five (5) seconds or until the furnace goes into lockout. If the control detects a failure it will now be shown on the diagnostic indicator light. Refer to the *Abnormal Operation* section in the *Sequence of Operation* section of this manual for more detail on failure codes.

The indicator light may be viewed by looking through the sight glass in the blower compartment door. If the blower compartment door is removed, failure to hold the door switch closed while removing the blower compartment door will result in the loss of the stored failure code. In most cases recycling the ignition control will result in the same failure code originally displayed.

SERVICING

Amana® brand 80% and 90% Single-Stage (ADS8, AMS8, ACS9, AMS9, AMS95)

NOTE: The models above use **White-Rodgers 50A65-289** ignition control board.

1. Check for 120 volts from Line 1 (Hot) to Line 2 (Neutral) at the ignition control. No voltage, check the door switch connections and wire harness for continuity.
2. Check for 24 volts from W to C terminal on the ignition control. No voltage. Check transformer, room thermostat, and wiring.

If you have 24 volts coming off the transformer but receive approximately 13 volts on the terminal board between (C) and (R), check for blown fuse.

3. Check for 120 volts to the induced draft blower by measuring voltage between terminals 1 and 4 (on the 4-pin connector) shown below. No voltage, replace ignition control.

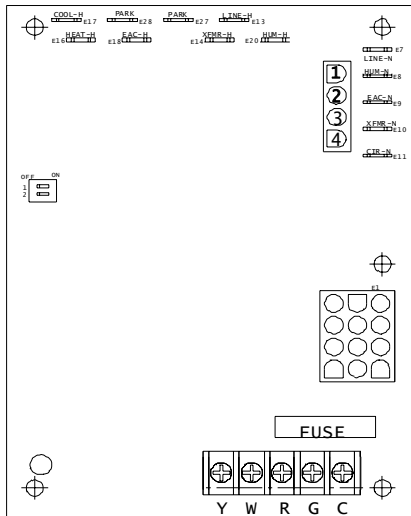

(ADS8, AMS8, ACS9, AMS9, AMS95)
(WR50A65-289)

4. If voltage is present in Steps 1 through 3 and the induced draft blower is operating, check voltage to the ignitor during the preheat cycle. Measure voltage between Pin 2 and Pin 3 shown above. No voltage, check pressure switch.
5. After the ignitor warmup time, begin checking for 24 volts to the gas valve. Voltage will be present for seven seconds only if proof of flame has been established.

Amana® brand 80% and 90% Two-Stage (ADV8, AMV8, ACV9, AMV9)

NOTE: The models above use **White-Rodgers 50V61-289** ignition control board.

1. Check for 120 volts from Line 1 (Hot) to Line 2 (Neutral) at the ignition control. No voltage, check the door switch connections and wire harness for continuity.
2. Check for 24 volts from W1 to C terminal on the ignition control. No voltage. Check transformer, room thermostat, and wiring.

If you have 24 volts coming off the transformer but receive approximately 13 volts on the terminal board between (C) and (R), check for blown fuse.

3. Check for 120 volts to the induced draft blower (low-stage) by measuring voltage between Pin 3 and Pin 4 (on the 5-pin connector) shown below. No voltage, check for loose connection in the 5-pin connector or replace ignition control shown below.

Check for 120 volts to the induced draft blower (high-stage) by measuring voltage between Pin 2 and Pin 4 (on the 5-pin connector) shown below. No voltage, check for loose connection in the 5-pin connector, no call for high stage heat or replace ignition control show below.

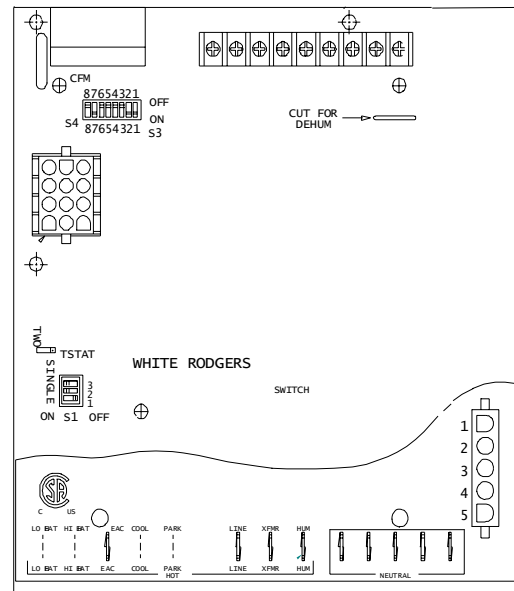

(ADV8, AMV8, ACV9, AMV9)
(WR50V61-289)

4. If voltage is present in Steps 1 through 3 and the induced draft blower is operating, check for voltage to the ignitor during the preheat cycle. Measure voltage between Pin 1 and Pin 5 (on the 5-pin connector) shown on previous picture. No voltage, check pressure switch or replace the ignition control board.
5. After the ignitor warmup time, begin checking for 24 volts to the gas valve. Voltage will be present for seven seconds only if proof of flame has been established.
6. If proof of flame was established voltage will be provided to the air circulation blower following the heat on delay period.

SERVICING

- a. BEFORE replacing the ECM motor assembly or the end bell, first check the motor with a GE TECMate PRO tester. If the motor runs with the tester, the motor is good. To check the end bell, see the previous variable speed testing section of this manual before replacing the end bell.
- b. The two-stage variable speed furnaces should have 120 Volts at the motor at all times, even without a call for cooling or heating. These motors receive their operational signals (24 Volts) through the 16-pin wiring harness, connected between the motor and integrated control board. **NOTE:** For complete troubleshooting information on units using the ECM/ICM blower motors, refer to the *servicing section - Checking Air Circulator Blowers (S-16B and S-16C)* in this service manual.

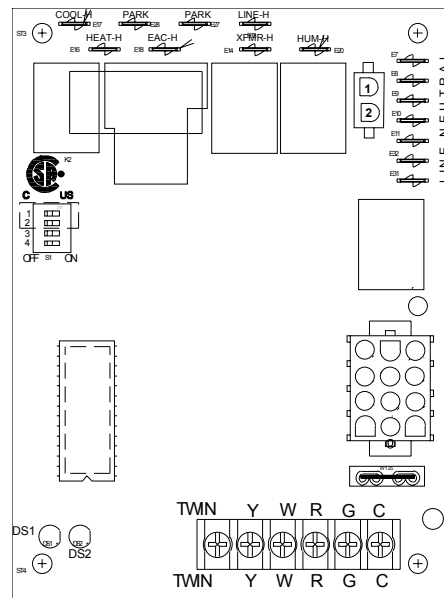

GDS8, GHS8, GMS8, GCS9, GMS9, GMS95, DDS8, DHS8, DMS8, DCS9, DMS9
(WR50A55-289)

Goodman® and Amana® Distinctions™ Brand 80% and 90% Single-Stage (GDS8, GHS8, GMS8, GCS9, GMS9, GMS95, DDS8, DHS8, DMS8, DCS9, DMS9)

NOTE: The models above use White-Rodgers 50A55-289 ignition control board.



These tests must be completed within a given time frame due to the operation of the ignition control.

1. Check for 120 volts from Line 1 (Hot) to Line 2 (Neutral) at the ignition control. No voltage, check the door switch connections and wire harness for continuity.
2. Check for 24 volts from W to C terminal on the ignition control. No voltage. Check transformer, room thermostat, and wiring.
If you have 24 volts coming off the transformer but receive approximately 13 volts on the terminal board between (C) and (R), check for blown fuse.
3. Check for 120 volts to the induced draft blower by measuring voltage between Pin 1 (on the 2-pin connector) and Line (Neutral) on the control board. No voltage, replace ignition control.
4. If voltage is present in Steps 1 through 3 and the induced draft blower is operating, check for 120 volts to the ignitor during the preheat cycle. Measure voltage between Pin 2 (on the 2-pin connector) and Line (Neutral) on the control board. No voltage, check pressure switch.
5. After the ignitor warmup time, begin checking for 24 volts to the gas valve. Voltage will be present for seven seconds only if proof of flame has been established.

Goodman® 80% and 90% Two-Stage (GMV8, GCV9, GMV9, GMV95)

NOTE: The models above use White-Rodgers 50V51-289 ignition control board.

1. Check for 120 volts from Line 1 (Hot) to Line 2 (Neutral) at the ignition control. No voltage, check the door switch connections and wire harness for continuity.
2. Check for 24 volts from W1 to C terminal on the ignition control. No voltage. Check transformer, room thermostat, and wiring.
If you have 24 volts coming off the transformer but receive approximately 13 volts on the terminal board between (C) and (R), check for blown fuse.
3. Check for 120 volts to the induced draft blower (low-stage) by measuring voltage between Pin 3 and Pin 4 (on the 5-pin connector) located on circuit board. No voltage, check for loose connection in the 5-pin connector or replace ignition control.
Check for 120 volts to the induced draft blower (high-stage) by measuring voltage between Pin 2 and Pin 4 (on the 5-pin connector) located on circuit board. No voltage, check for loose connection in the 5-pin connector, no call for high stage heat or replace ignition control.

SERVICING

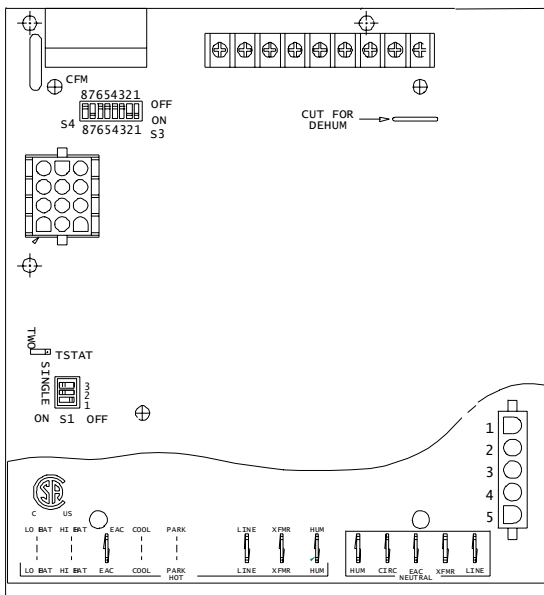

**(GMV8, GCV9, GMV9, GMV95)
(WR60V61-289)**

4. If voltage is present in Steps 1 through 3 and the induced draft blower is operating, check for 120 volts to the ignitor during the preheat cycle. Measure voltage between Pin 1 and Pin 5 (on the 5-pin connector) located on ignition control. No voltage, check pressure switch or replace the ignition control board.
5. After the ignitor warmup time, begin checking for 24 volts to the gas valve. Voltage will be present for seven seconds only if proof of flame has been established.
6. If proof of flame was established voltage will be provided to the air circulation blower following the heat on delay period.
 - a. BEFORE replacing the ECM motor assembly or the end bell, first check the motor with a GE TECMate PRO tester. If the motor runs with the tester, the motor is good. To check the end bell, see the previous variable speed testing section of this manual before replacing the end bell.
 - b. The two-stage variable speed furnaces should have 120 Volts at the motor at all times, even without a call for cooling or heating. These motors receive their operational signals (24 Volts) through the 16-pin wiring harness, connected between the motor and integrated control board. **NOTE:** For complete troubleshooting information on units using the ECM/ICM blower motors, refer to the *servicing section - Checking Air Circulator Blowers (S-16B and S-16C)* in this service manual.

Goodman® and Amana® brand 80% and 90% Two-Stage (AMH8, GME8, GMH8, AMH95, GMH95, GCH9)

NOTE: The models above use **White-Rodgers 50M56-289** ignition control board.

1. Check for 120 volts from Line 1 (Hot) to Line 2 (Neutral) at the ignition control. No voltage, check the door switch connections and wire harness for continuity.
2. Check for 24 volts from W1 to C terminal on the ignition control. No voltage. Check transformer, room thermostat, and wiring.

If you have 24 volts coming off the transformer but receive approximately 13 volts on the terminal board between (C) and (R), check for blown fuse.

3. Check for 120 volts to the induced draft blower (low-stage) by measuring voltage between Pin 3 and Pin 4 (on the 5-pin connector) located on circuit board. No voltage, check for loose connection in the 5-pin connector or replace ignition control.

Check for 120 volts to the induced draft blower (high-stage) by measuring voltage between Pin 2 and Pin 4 (on the 5-pin connector) located on circuit board. No voltage, check for loose connection in the 5-pin connector, no call for high stage heat or replace ignition control.

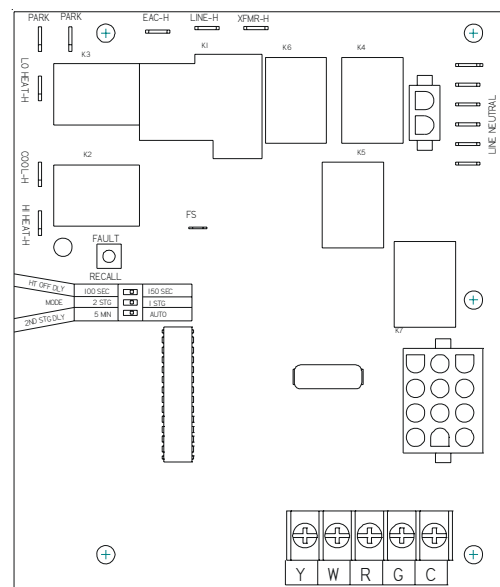

**(AMH8, GME8, GMH8, GCH8)
WR50M56-289**

4. If voltage is present in Steps 1 through 3 and the induced draft blower is operating, check for 120 volts to the ignitor during the preheat cycle. Measure voltage between Pin 1 and Pin 5 (on the 5-pin connector) located on ignition control. No voltage, check pressure switch or replace the ignition control board.
5. After the ignitor warmup time, begin checking for 24 volts to the gas valve. Voltage will be present for seven seconds only if proof of flame has been established.

SERVICING

6. If proof of flame was established voltage will be provided to the air circulation blower following the heat on delay period.
 - a. BEFORE replacing the ECM motor assembly or the end bell, first check the motor with a GE TECMate PRO tester. If the motor runs with the tester, the motor is good. To check the end bell, see the previous variable speed testing section of this manual before replacing the end bell.
 - b. The two-stage variable speed furnaces should have 120 Volts at the motor at all times, even without a call for cooling or heating. These motors receive their operational signals (24 Volts) through the 16-pin wiring harness, connected between the motor and integrated control board. **NOTE:** For complete troubleshooting information on units using the ECM/ICM blower motors, refer to the *servicing section - Checking Air Circulator Blowers (S-16B and S-16C)* in this service manual.

S-314 CHECKING FLAME SENSOR

A flame sensing device is used in conjunction with the ignition control module to prove combustion. If proof of flame is not present the control will de-energize the gas valve and "retry" for ignition or lockout.

The following drawings illustrate from a bottom view, the approximate distances for the ignitor and flame sensor to the gas inshot burner. You will note they are in the main burner stream, not in the carry over ports as shown in the following figure.

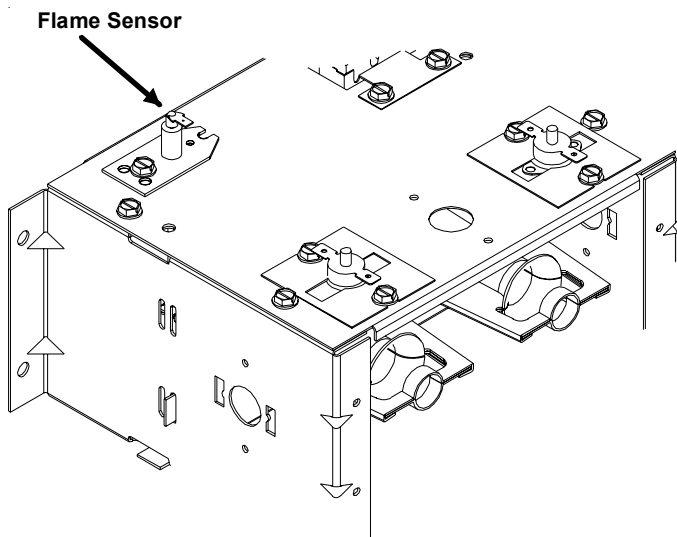

Models with Integrated Ignition Control & Flame Sensor Probe (80% Upflow Model Shown, Counterflow Similar)

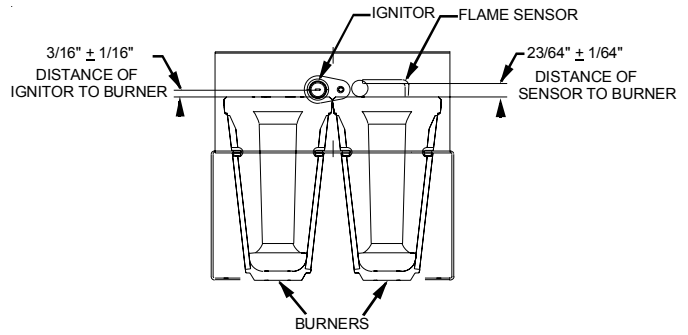

Models with Integrated Ignition Control & Flame Sensor Probe (90% Upflow Model Shown, Counterflow Similar)

WARNING	
HIGH VOLTAGE DISCONNECT ALL POWER BEFORE SERVICING OR INSTALLING THIS UNIT. MULTIPLE POWER SOURCES MAY BE PRESENT. FAILURE TO DO SO MAY CAUSE PROPERTY DAMAGE, PERSONAL INJURY OR DEATH.	

1. On all 80% models disconnect the orange flame sensor wire from the sensor or on all 90% models disconnect the blue flame sensor wire from the sensor.
2. Connect a micro-amp meter in series with this wire and the sensor terminal.
3. Be sure the positive side of the meter is to Orange or Blue wire (depending on the model) and the negative side of the meter is to sensor terminal.

WARNING
LINE VOLTAGE NOW PRESENT

4. Place the unit into a heating cycle.
5. As soon as flame is established a micro-amp reading should be evident once proof of flame (micro-amp reading) is established, the hot surface ignitor will be de-energized.
6. The Integrated Ignition controls will have 1 to 4 micro-amps. If the micro-amp reading is less than the minimum specified, check for high resistance wiring connections, sensor to burner gap, dirty flame sensor, or poor grounding.
7. If absolutely no reading, check for continuity on all components and if good - replace ignition control module.

NOTE: Contaminated fuel or combustion air can create a nearly invisible coating on the flame sensor. This coating works as an insulator causing a loss in the flame sense signal. If this situation occurs the flame sensor must be cleaned with steel wool.

ACCESSORY WIRING DIAGRAMS



WARNING

HIGH VOLTAGE!
DISCONNECT ALL POWER BEFORE SERVICING OR INSTALLING THIS UNIT. MULTIPLE POWER SOURCES MAY BE PRESENT. FAILURE TO DO SO MAY CAUSE PROPERTY DAMAGE, PERSONAL INJURY OR DEATH.



ALL FUEL SYSTEM CONTROL BOARD - AFE1860A

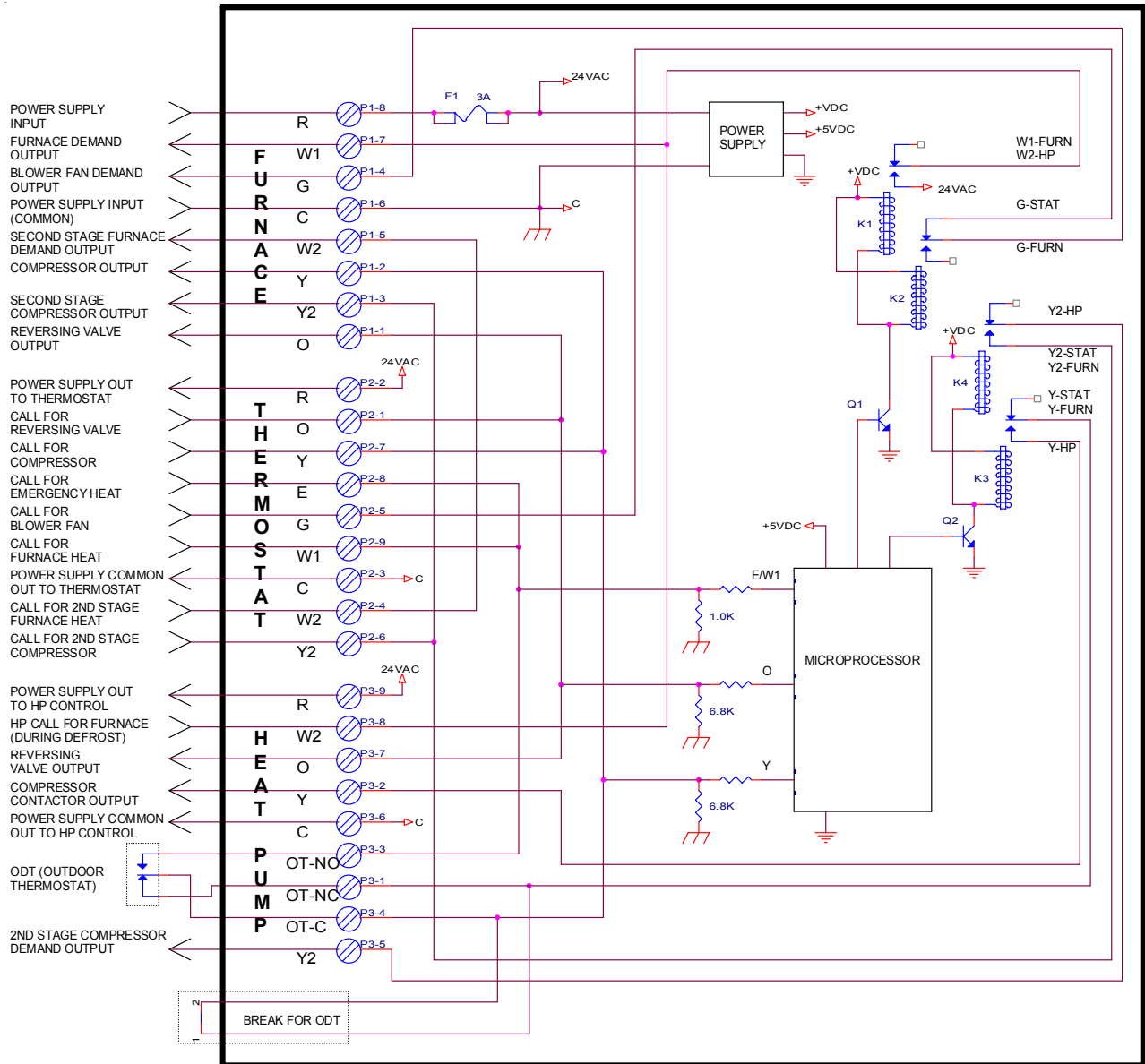

ALL FUEL SYSTEM CONTROL BOARD - AFE18-60A

This wiring diagram is for reference only. Not all wiring is as shown above.

Refer to the appropriate wiring diagram for the unit being serviced.

(For use with Heat Pumps in conjunction with 80% or 90% Single-Stage or Two-Stage Furnaces)

ACCESSORY WIRING DIAGRAMS

WARNING

HIGH VOLTAGE!
 DISCONNECT ALL POWER BEFORE SERVICING OR INSTALLING THIS UNIT. MULTIPLE POWER SOURCES MAY BE PRESENT. FAILURE TO DO SO MAY CAUSE PROPERTY DAMAGE, PERSONAL INJURY OR DEATH.

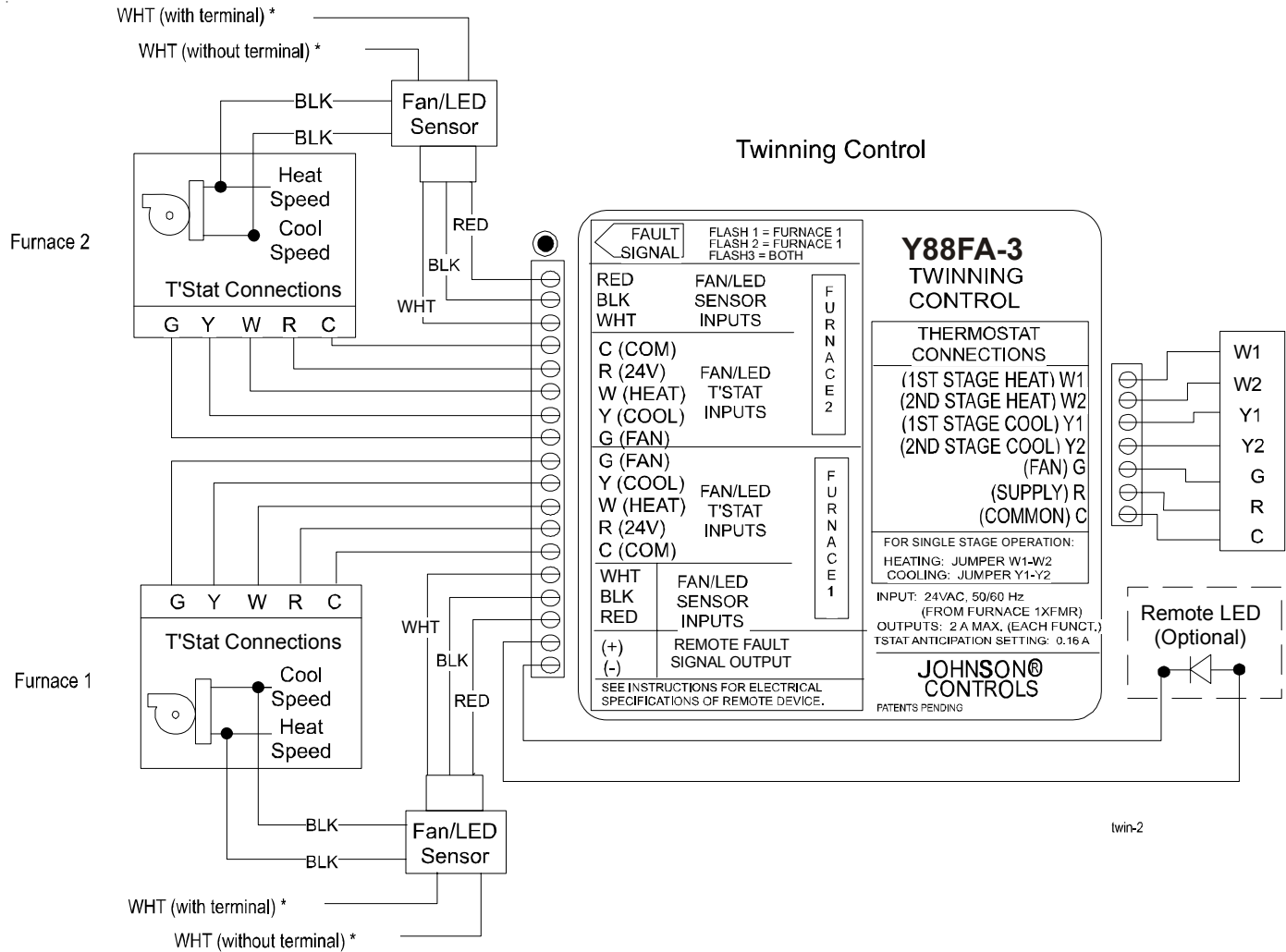

*Tape wire ends if not used.

FURNACE TWINNING KIT - FTK03A

This wiring diagram is for reference only. Not all wiring is as shown above.
 Refer to the appropriate wiring diagram for the unit being serviced.
 (For use only with 80% or 90% Single-Stage Furnaces)

ACCESSORY WIRING DIAGRAMS

WARNING

HIGH VOLTAGE!
DISCONNECT ALL POWER BEFORE SERVICING OR INSTALLING THIS UNIT. MULTIPLE POWER SOURCES MAY BE PRESENT. FAILURE TO DO SO MAY CAUSE PROPERTY DAMAGE, PERSONAL INJURY OR DEATH.

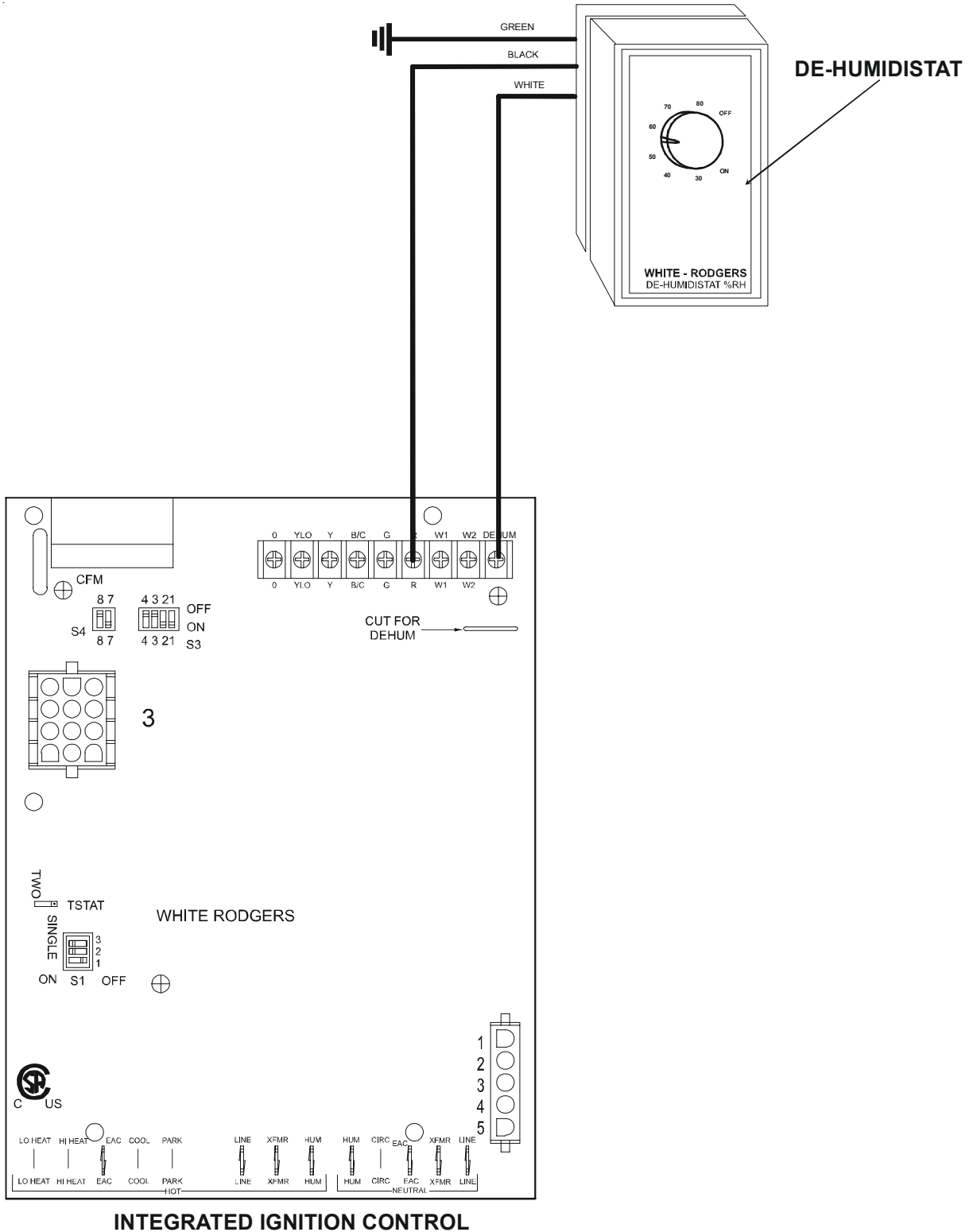

DE-HUMIDISTAT - DEHUM1

This wiring diagram is for reference only. Not all wiring is as shown above.
 Refer to the appropriate wiring diagram for the unit being serviced.
 (Two-Stage Variable Speed Furnace)