



Service and Maintenance Procedures

2-SPEED, 2-STAGE INDUCED-COMBUSTION GAS-FIRED FURNACE

330AAV 331AAV Series C&D

Cancels: SP04-55

SP04-66
10-00

NOTE: Read the entire instruction manual before starting the installation.

TABLE OF CONTENTS

SAFETY CONSIDERATIONS	1
INTRODUCTION	2
ELECTROSTATIC DISCHARGE (ESD) PRECAUTIONS PROCEDURE	2
CARE AND MAINTENANCE	2
Cleaning and/or Replacing Air Filter.....	2
Blower Motor and Wheel.....	3
Cleaning Heat Exchanger.....	5
Electrical Controls and Wiring.....	6
WIRING DIAGRAMS.....	7
Troubleshooting.....	9

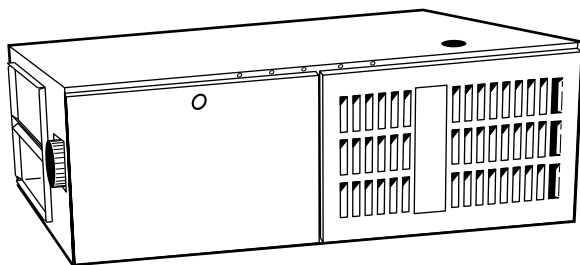

A94087

Fig. 1—Model 331AAV Horizontal

SAFETY CONSIDERATIONS

Installing and servicing heating equipment can be hazardous due to gas and electrical components. Only trained and qualified personnel should install, repair, or service heating equipment.

Untrained personnel can perform basic maintenance functions such as cleaning and replacing air filters. All other operations must be performed by trained service personnel. When working on heating equipment, observe precautions in the literature, tags, and labels attached to or shipped with the unit and other safety precautions that may apply.

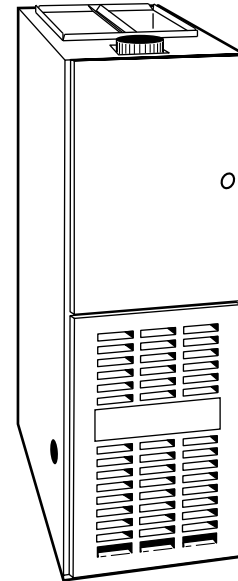

A94086

Fig. 2—Model 331AAV Downflow

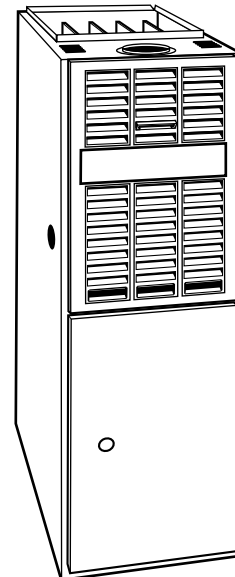

A94085

Fig. 3—Model 330AAV Upflow

Follow all safety codes. In the United States, follow all safety codes including the National Fuel Gas Code NFPA No. 54-1999/ANSI Z223.1-1999. In Canada, refer to the current edition of the National Standard of Canada CAN/CGA-B149.1- and .2-M95 Natural Gas and Propane Gas Installation Codes. Wear safety glasses and work gloves. Have fire extinguisher available during start-up and adjustment procedures and service calls.

Recognize safety information. This is the safety-alert symbol . When you see this symbol on the furnace and in instructions or manuals, be alert to the potential for personal injury.

Understand these signal words; DANGER, WARNING, and CAUTION. These words are used with the safety-alert symbol. DANGER identifies the most serious hazards which **will** result in severe personal injury or death. WARNING signifies hazards which **could** result in personal injury or death. CAUTION is used to identify unsafe practices which **would** result in minor personal injury or product and property damage. NOTE is used to highlight suggestions which **will** result in enhanced installation, reliability, or operation

	<p>WARNING: The ability to properly perform maintenance on this equipment requires certain expertise, mechanical skills, tools, and equipment. If you do not possess these, do not attempt to perform any maintenance on this equipment other than those procedures recommended in the User's Manual. A FAILURE TO FOLLOW THIS WARNING COULD RESULT IN POSSIBLE DAMAGE TO THIS EQUIPMENT, SERIOUS PERSONAL INJURY, OR DEATH.</p>
---	---

INTRODUCTION

These instructions are written for the 2-Speed, 2-Stage, Induced Combustion, Gas-Fired Furnace.

ELECTROSTATIC DISCHARGE (ESD) PRECAUTIONS PROCEDURE

	<p>CAUTION: Electrostatic discharge can affect electronic components. Take precautions during furnace installation and servicing to protect the furnace electronic control. Precautions will prevent electrostatic discharges from personnel and hand tools which are held during the procedure. These precautions will help to avoid exposing the control to electrostatic discharge by putting the furnace, the control, and the person at the same electrostatic potential.</p>
---	---

1. Disconnect all power to the furnace. **DO NOT TOUCH THE CONTROL OR ANY WIRE CONNECTED TO THE CONTROL PRIOR TO DISCHARGING YOUR BODY'S ELECTROSTATIC CHARGE TO GROUND.**
2. Firmly touch a clean, unpainted, metal surface of the furnace chassis which is close to the control. Tools held in a person's hand during grounding will be satisfactorily discharged.
3. After touching the chassis you may proceed to service the control or connecting wires as long as you do nothing that recharges your body with static electricity (for example; **DO NOT** move or shuffle your feet, **DO NOT** touch ungrounded objects, etc.).
4. If you touch ungrounded objects (recharge your body with static electricity), firmly touch furnace again before touching control or wires.
5. Use this procedure for installed and uninstalled (ungrounded) furnaces.
6. Before removing a new control from its container, discharge your body's electrostatic charge to ground to protect the control from damage. If the control is to be installed in a furnace, follow items 1. through 5. before bringing the control or yourself into contact with the furnace. Put all used **AND** new controls into containers before touching ungrounded objects.

7. An ESD service kit (available from commercial sources) may also be used to prevent ESD damage.

CARE AND MAINTENANCE

For continuing high performance and to minimize possible equipment failure, it is essential that periodic maintenance be performed on this equipment. Consult your local dealer as to proper frequency of maintenance and availability of a maintenance contract.

	<p>WARNING: Never store anything on, near, or in contact with furnace, such as:</p> <ol style="list-style-type: none">1. Spray or aerosol cans, rags, brooms, dust mops, vacuum cleaners, or other cleaning tools.2. Soap powders, bleaches, waxes or other cleaning compounds, plastic or plastic containers, gasoline, kerosene, cigarette lighter fluid, dry cleaning fluids, or other volatile fluids.3. Paint thinners and other painting compounds, paper bags or other paper products. <p>A failure to follow this warning could result in corrosion of the heat exchanger, fire, personal injury, or death.</p>
---	--

	<p>WARNING: Turn off gas and electrical supplies to unit before performing any maintenance or service on it. Follow operating instructions on label attached to furnace. A failure to follow this warning could result in personal injury.</p>
---	---

The minimum maintenance that should be performed on this equipment is as follows:

1. Check and clean air filter each month or more frequently if required. Replace if torn.
2. Check blower motor and wheel for cleanliness each heating and cooling season. Clean as necessary.
3. Check electrical connections for tightness and controls for proper operation each heating season. Service as necessary.

	<p>CAUTION: As with any mechanical equipment, personal injury can result from sharp metal edges, etc.; therefore, be careful when removing parts.</p>
---	--

I. CLEANING AND/OR REPLACING AIR FILTER

The air filter arrangement may vary depending on the application.

NOTE: If the filter has an airflow direction arrow, the arrow must point toward the blower.

	<p>WARNING: Never operate unit without a filter or with filter access door removed. A failure to follow this warning could result in fire, personal injury, or death.</p>
---	--

To clean or replace filters, proceed as follows:

1. Horizontal and Downflow—filters installed in return-air duct (see Figs. 4 and 5)
 - a. Turn off electrical supply before removing blower access door.
 - b. Remove blower access door.
 - c. Reach up behind top plate, tilt filters toward center of return-air plenum, remove filters, and clean as needed. Replace if torn.
 - d. Furnaces are equipped with permanent, washable filters.
 - e. Clean filters by spraying tap water through filter from opposite direction of airflow.

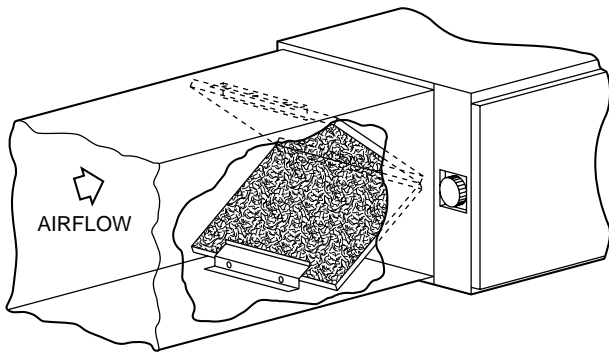

Fig. 4—Horizontal Filter Arrangement

A94307

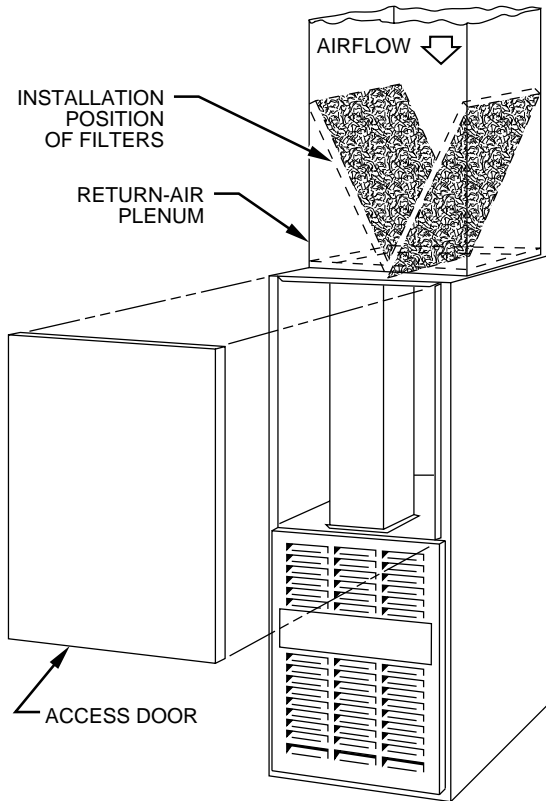

Fig. 5—Downflow Filter Arrangement

A88486

- f. Rinse and let dry. Oiling or coating of filters is not recommended or required.
 - g. Reinstall filters.
 - h. Replace blower access door and turn on electrical supply to furnace.
2. Upflow—filters installed in media cabinet adjacent to furnace (See Fig. 6)
 - a. Turn off electrical supply to furnace
 - b. Remove filter cabinet door.
 - c. Slide filter out of cabinet.
 - d. If equipped with permanent, washable filter, clean filter by spraying cold tap water through filter in opposite direction of airflow. Rinse filter and let dry. Oiling or coating of the filter is not recommended.
 - e. If equipped with factory-specified disposable media filter, replace only with media filter having the same part number and size.
 - f. Slide filter into cabinet.

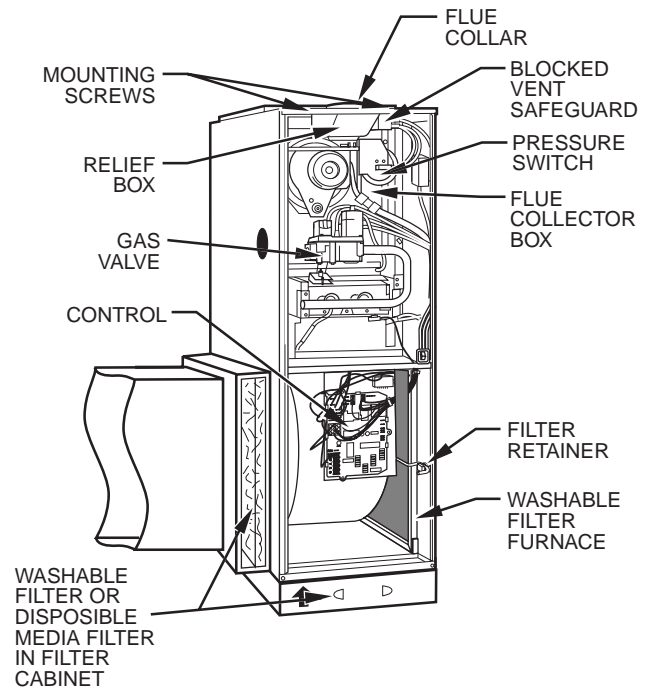

Fig. 6—Model 330AAV Upflow

A00293

- g. Replace filter cabinet door.
 - h. Turn on electrical supply to furnace.
3. Upflow—filter(s) installed in side(s) and/or bottom of blower compartment (See Fig. 6)
 - a. Turn off electrical supply before removing blower and control access doors.
 - b. Release filter retainer from clip at front of furnace casing. (See Fig. 6.) For side return, clips may be used on either or both sides of the furnace.
 - c. Slide filter out.
 - d. Clean filters by spraying tap water through filter from opposite direction of airflow.
 - e. Rinse and let dry. Oiling or coating of filter is not recommended or required.
 - f. Place filter in furnace.
 - g. Replace blower and control access doors and turn on electrical supply to furnace.

II. BLOWER MOTOR AND WHEEL

The following items should be performed by a qualified service technician:

To ensure long life, economy, and high efficiency, clean accumulated dirt and grease from blower wheel and motor annually.

The inducer and blower motors are pre-lubricated and require no additional lubrication. These motors can be identified by the absence of oil ports on each end of the motor.

Clean blower motor and wheel as follows:

1. Turn off electrical supply to furnace.
2. Remove blower access door.

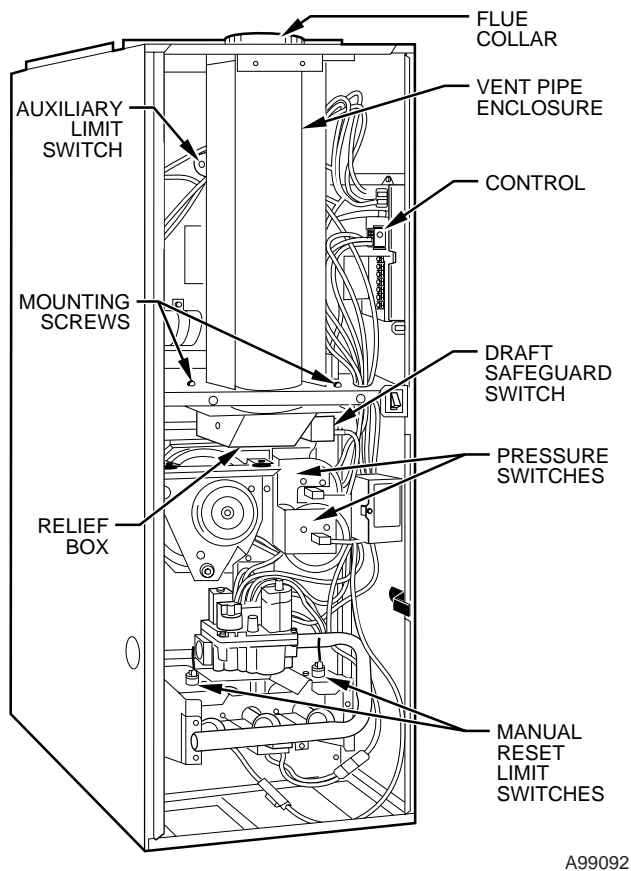

Fig. 7—Model 331AAV Downflow

A99092

3. Downflow/horizontal only.

- a. Disconnect vent connector from furnace flue collar. (See Fig. 7.)
- b. Disconnect and remove vent pipe enclosure. Push bottom side backward to release tabs.
- c. Disconnect and remove short piece of vent pipe from within furnace.

NOTE: Vent pipe is screwed and RTV sealed to relief box.

4. Disconnect blower leads from furnace control. Notice wire color and location for reassembly. Also, disconnect auxiliary limit switch leads (downflow/horizontal only, if present). All other factory wires can be left connected, but field thermostat connections may need to be disconnected depending on their length and routing.
5. Remove screw securing control box support to furnace.
6. Hang control box and transformer assembly to front of furnace casing.
7. Remove screws holding blower assembly to blower deck and slide blower assembly out of furnace.
8. Clean blower wheel and motor using a vacuum with soft brush attachment. Do not remove or disturb balance weights (clips) on blower wheel blades. The blower wheel should not be dropped or bent as balance will be affected.
9. If greasy residue is present on blower wheel, remove wheel from the blower housing and wash it with an appropriate degreaser. To remove wheel:
 - a. Mark blower wheel location on shaft before disassembly to ensure proper reassembly.
 - b. Loosen setscrew holding blower wheel on motor shaft.

NOTE: Mark blower mounting arms, motor, and blower housing so motor and each arm is positioned at the same location during reassembly.

- c. Mark blower wheel orientation and cutoff plate location to ensure proper reassembly.
 - d. Remove screws securing cutoff plate and remove cutoff plate from housing.
 - e. Remove bolts holding motor mounts to blower housing and slide motor and mounts out of housing. Disconnect capacitor and ground wire attached to blower housing before removing motor.
 - f. Remove blower wheel from housing.
10. Reassemble motor and blower by reversing items 9a through 9f. Be sure to reattach ground wire.
 11. Reinstall blower assembly in furnace.
 12. Reinstall control box and support assembly in furnace.
 13. Reconnect blower leads to furnace control and auxiliary limit switch leads (downflow/horizontal only). Refer to furnace wiring diagram, and connect thermostat leads if previously disconnected. (See Fig. 12.)

NOTE: Refer to Table 1 for motor speed lead relocation if leads were not identified before disconnection

TABLE 1—SPEED SELECTOR

COLOR	SPEED	FACTORY-ATTACHED TO
Black	High	Cool
Yellow (When Present)	Medium High	Spare
Blue	Medium Low	Heat
Red	Low	Spare
White	Common	Com
Orange (When Present)	Medium	Spare

⚠	CAUTION: Heating speed selection MUST be adjusted to provide proper temperature rise as specified on the rating plate. Failure to adjust the heating speed may shorten heat exchanger life.
---	---

14. Reinstall internal vent pipe and enclosure on downflow/horizontal furnaces only by reversing items 3a through 3c.

NOTE: A releasing agent such as PAM cooking spray or equivalent (must not contain corn or canola oil, aromatic or halogenated hydrocarbons or inadequate seal may occur) and RTV sealant (G.E. 162, 6702, or Dow-Corning 738) are needed before starting installation. **DO NOT** substitute any other type of RTV sealant. G.E. 162 (P771-9003) is available through RCD in 3-oz tubes.

15. Reinstall vent connector to furnace flue collar. After fully assembling vent connector to furnace flue collar, securely fasten vent connector to flue collar with 2 field-supplied, corrosion-resistant, sheet metal screws located 180 degrees apart and midway up the collar.
16. Turn on electrical supply. Manually close blower access door switch. Use a piece of tape to hold switch closed. Check for proper rotation and speed changes between heating and cooling by jumpering R to W and then R to Y on furnace control thermostat terminals.

WARNING: Blower access door switch opens 115-v power to control center. No component operation can occur. Caution must be taken when manually closing this switch for service purposes. Failure to follow this warning could result in electrical shock, personal injury, or death.

NOTE: If thermostat terminals are jumpered before blower access door switch is closed, blower will run for 90 sec before beginning a heating or cooling cycle.

17. If furnace is operating properly, release blower access door switch, replace blower access door.

III. CLEANING HEAT EXCHANGER

The following steps should be performed by a qualified service technician:

NOTE: If the heat exchangers get a heavy accumulation of soot and carbon, they should be replaced rather than trying to clean them thoroughly due to their intricate design. A build-up of soot and carbon indicates that a problem exists which needs to be corrected, such as improper adjustment of manifold pressure, insufficient or poor quality combustion air, incorrect size, or damaged manifold orifice(s), improper gas, or a restricted heat exchanger. Action must be taken to correct the problem.

If it becomes necessary to clean heat exchanger because of light dust or corrosion proceed as follows:

1. Turn gas and power to furnace to OFF.
2. Remove control and blower access doors.
3. Disconnect vent connector from furnace flue collar.
4. Disconnect internal vent pipe and enclosure.
 - a. Remove vent pipe enclosure cover on downflow/horizontal furnaces only.
 - b. Disconnect and remove short piece of vent pipe from within furnace.

NOTE: Vent pipe is screwed and RTV sealed to relief box.

- c. Remove vent pipe enclosure by removing screw in upper back. Push bottom side backward to release tabs.
5. Remove 2 screws that secure relief box. (See Fig. 6 or 7.)
6. Disconnect wires to the following components. Mark wires to aid in reconnection of:
 - a. Draft safeguard switch.
 - b. Inducer motor.
 - c. Pressure switch(es).
 - d. Limit overtemperature switch(es).
 - e. Gas valve.
 - f. Hot surface ignitor.
 - g. Flame-sensing electrode
7. Remove complete inducer assembly and relief box from furnace.
8. Remove screws that secure flue collector box to center panel. Be careful not to damage collector box.
9. Remove cell outlet plates.

IMPORTANT: Replace screws in center panel before cleaning.

10. Remove burner assembly and cell inlet plates.

IMPORTANT: Replace screws in center panel before cleaning.

NOTE: Be very careful when removing burner assembly to avoid breaking ignitor. See Fig. 8 for correct ignitor location.

11. Using field-provided small wire brush, steel spring cable, reversible electric drill, and vacuum cleaner, clean cells as follows:

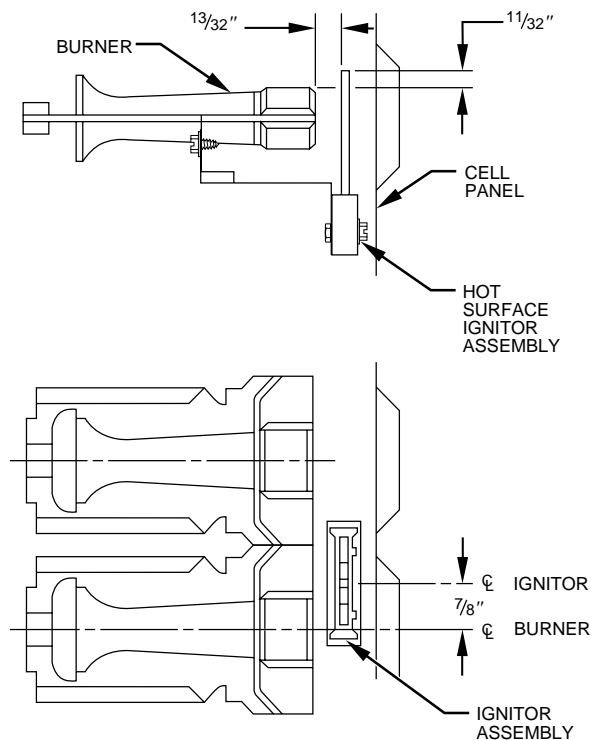

A93347

Fig. 8—Position of Ignitor to Burner

a. Assemble wire brush and steel spring cable.

- (1.) Use 48 in. of 1/4-in. diameter high-grade steel spring cable (commonly known as drain clean-out or Roto-Rooter cable).
- (2.) Use 1/4-in. diameter wire brush (commonly known as 25-caliber rifle cleaning brush).

NOTE: The materials needed in items (1.) and (2.) can usually be purchased at local hardware stores.

- (3.) Insert twisted wire end of brush into end of spring cable, and crimp tight with crimping tool or strike with ball-peen hammer. **TIGHTNESS IS VERY IMPORTANT.**

- (4.) Remove metal screw fitting from wire brush to allow insertion into cable.

b. Clean each heat exchanger cell.

- (1.) Attach variable-speed, reversible drill to end of spring cable (end opposite brush).
- (2.) Remove cell outlet plates.

IMPORTANT: Replace screws in center panel before cleaning.

- (3.) Insert brush end of cable into upper opening of cell and slowly rotate with drill. **DO NOT** force cable. Gradually insert at least 36 in. of cable into 2 upper passes of cell. (See Fig. 9.)
- (4.) Work cable in and out of cell 3 or 4 times to obtain sufficient cleaning. **DO NOT** pull cable with great force. Reverse drill and gradually work cable out.
- (5.) Insert brush end of cable in lower opening of cell, and proceed to clean 2 lower passes of cell in same manner as 2 upper passes.
- (6.) Repeat foregoing procedures until each cell in furnace has been cleaned.
- (7.) Using vacuum cleaner, remove residue from each cell.

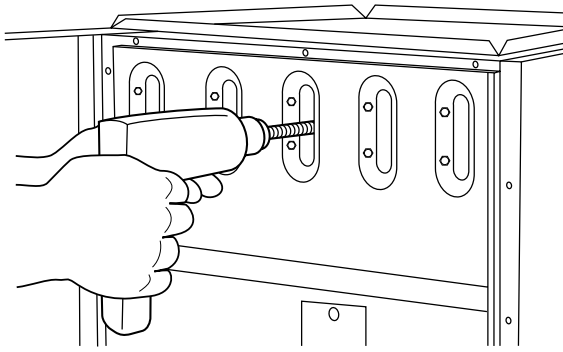

A91252

Fig. 9—Cleaning Heat Exchanger Cell

- (8.) Using vacuum cleaner with soft brush attachment, clean burner assembly.
- (9.) Reinstall cell outlet plates and screws FIRST; then, reinstall cell inlet plates and burner assembly. Care must be exercised to center burners in cell openings.

12. Remove old sealant from center panel and collector box flange and apply new sealant to collector box flange and reinstall on center panel, making sure all screws are secure.

NOTE: A releasing agent such as PAM cooking spray or equivalent (must not contain corn or canola oil, aromatic or halogenated hydrocarbons or inadequate seal may occur) and RTV sealant (G.E. 162, 6702, or Dow-Corning 738) are needed before starting installation. DO NOT substitute any other type of RTV sealant. G.E. 162 (P771-9003) is available through RCD in 3-oz tubes.

13. Reinstall relief box and inducer assembly.

NOTE: If inducer assembly gasket is damaged, use RTV sealant to seal inducer assembly to collector box.

NOTE: A releasing agent such as PAM cooking spray or equivalent (must not contain corn or canola oil, aromatic or halogenated hydrocarbons or inadequate seal may occur) and RTV sealant (G.E. 162, 6702, or Dow-Corning 738) are needed before starting installation. DO NOT substitute any other type of RTV sealant. G.E. 162 (P771-9003) is available through RCD in 3-oz tubes.

14. Reconnect wires to the following components:

- a. Draft safeguard switch.
- b. Inducer motor.
- c. Pressure switches.
- d. Limit overtemperature switch(es).
- e. Gas valve.
- f. Hot surface ignitor.
- g. Flame-sensing electrode.

15. Reinstall internal vent pipe and enclosure on downflow/horizontal furnaces only by reversing items 4a through 4c.

NOTE: A releasing agent such as PAM cooking spray or equivalent (must not contain corn or canola oil, aromatic or halogenated hydrocarbons or inadequate seal may occur) and RTV sealant (G.E. 162, 6702, or Dow-Corning 738) are needed before starting installation. DO NOT substitute any other type of RTV sealant. G.E. 162 (P771-9003) is available through RCD in 3-oz tubes.

16. Reinstall vent connector to furnace flue collar. After fully assembling vent connector to furnace flue collar, securely fasten vent connector to flue collar with 2 field-supplied, corrosion-resistant, sheet metal screws located 180 degrees apart and midway up the collar.
17. Replace blower access door only.
18. Turn power and gas to ON.

19. Set thermostat and check furnace for proper operation.
20. Verify blower airflow and speed changes between heating and cooling.
21. Check for gas leaks.
22. Replace control door.

	<p>WARNING: Never use a match or other open flame to check for gas leaks. Use a soap-and-water solution. A failure to follow this warning could result in fire, personal injury, or death.</p>
--	---

IV. ELECTRICAL CONTROLS AND WIRING

NOTE: There may be more than 1 electrical supply to unit.

The electrical ground and polarity for 115-v wiring must be maintained properly. Refer to Fig. 10 and 11 for field wiring information and to Fig. 12 for unit wiring information. If the polarity is NOT correct, the furnace control will display code 02 on the status LED and prevent heat operation. The control system also requires an earth ground for proper operation of the microprocessor.

With power disconnected to unit, check all electrical connections for tightness. Tighten all screws on electrical connections. If any smoky or burned connections are noticed, disassemble the connection, clean all parts and stripped wire, and reassemble properly and securely. Electrical controls are difficult to check without proper instrumentation; therefore, reconnect electrical power to unit and observe unit through 1 complete operating cycle.

The 24-v circuit contains an automotive-type, 3-amp fuse located on the main control. Any 24-v electrical shorts during installation, service, or maintenance could cause this fuse to blow. If fuse replacement is required, use ONLY a 3-amp fuse. The control will display code 24 when fuse needs replacement.

The control in this furnace is equipped with an LED status light to aid in installation, servicing, and troubleshooting. It can be viewed through the sight glass or window on blower access door. The control indicates status with the LED on continuously, rapid flashing, or a code composed of 2 digits. (The first digit is the number of short flashes, the second is the number of long flashes.) Refer to the service label on blower compartment door for code explanations and useful troubleshooting suggestions. (See Fig. 13.)

It is important to note that power to furnace must not be interrupted and furnace blower door must not be removed until the LED status code(es) is recorded. When power to control is interrupted, status memory is erased.

The control will store up to 5 previous codes but will not store non-current code longer than 48 hr. To retrieve previous codes, if present, no thermostat inputs to control must be present and all time delays must expire. Remove 1 of the red main limit wires 1 to 4 sec until the LED light goes out, then reconnect it. (See Figs. 6 and 7.) (Do not leave red wire disconnected for longer periods of time as control will assume an overtemperature condition exists and will respond with indoor blower operation.) This places control in status recall mode and displays first code stored in memory. Record code and repeat the disconnect and reconnect of red wire, recording each code until code 11 is displayed indicating no additional faults. After last code is displayed or after 2 minutes in the code recall mode, the control will return to normal standby mode.

Use any recorded fault codes, service label, and troubleshooting diagram to diagnose and correct any problem condition.

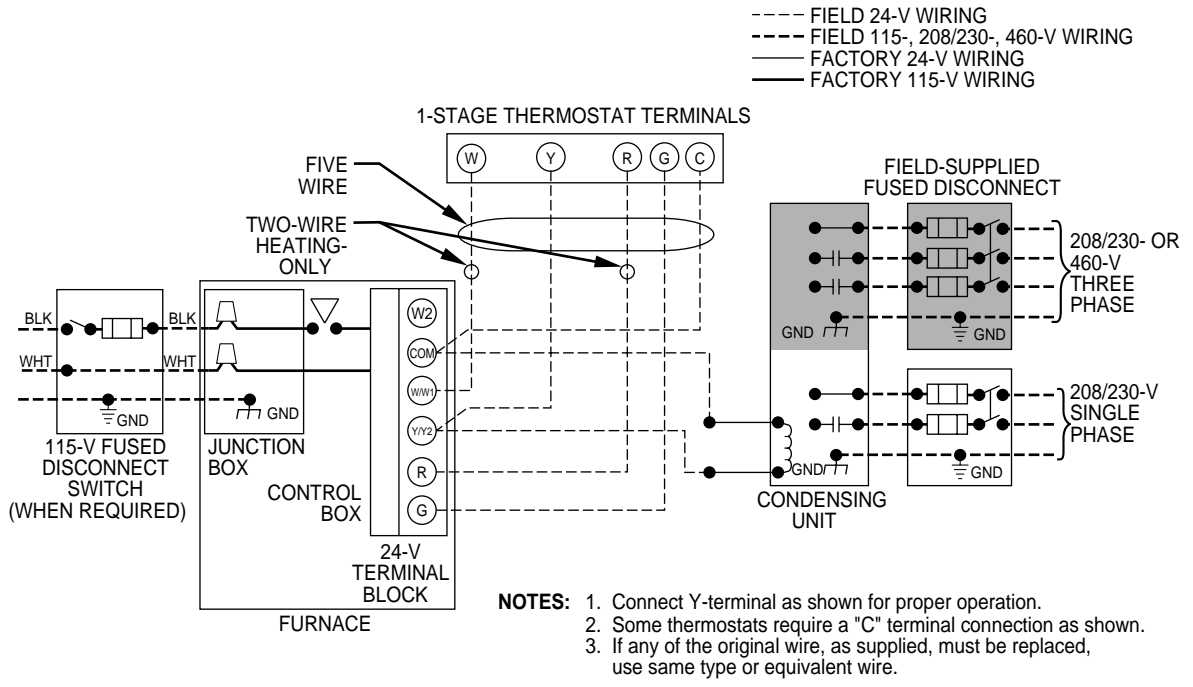

Fig. 10—Heating and Cooling Application Wiring Diagram

A99071

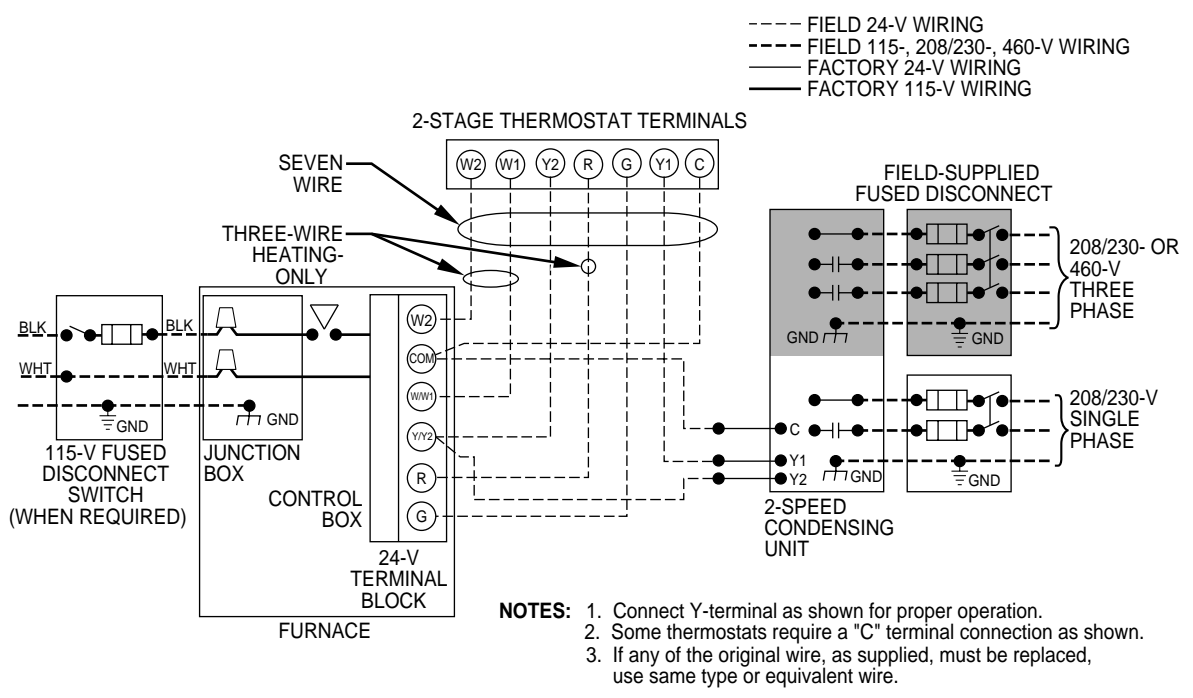

Fig. 11—Heating and Cooling Application Wiring Diagram for 2-Stage Thermostats and/or 2-Speed Condensing Units

A99072

WIRING DIAGRAMS

Refer to Fig. 10, 11, and 12 for the 330- and 331-AAV Series C & D wiring diagrams.

TROUBLESHOOTING

Refer to service label. (See Fig. 13.) The Troubleshooting Guide can be a useful tool in isolating furnace operation problems. Beginning with the word “Start,” answer each question and follow the appropriate arrow to the next item.

The Guide will help you identify the problem or failed component. After replacing any component, verify correct operation sequence.

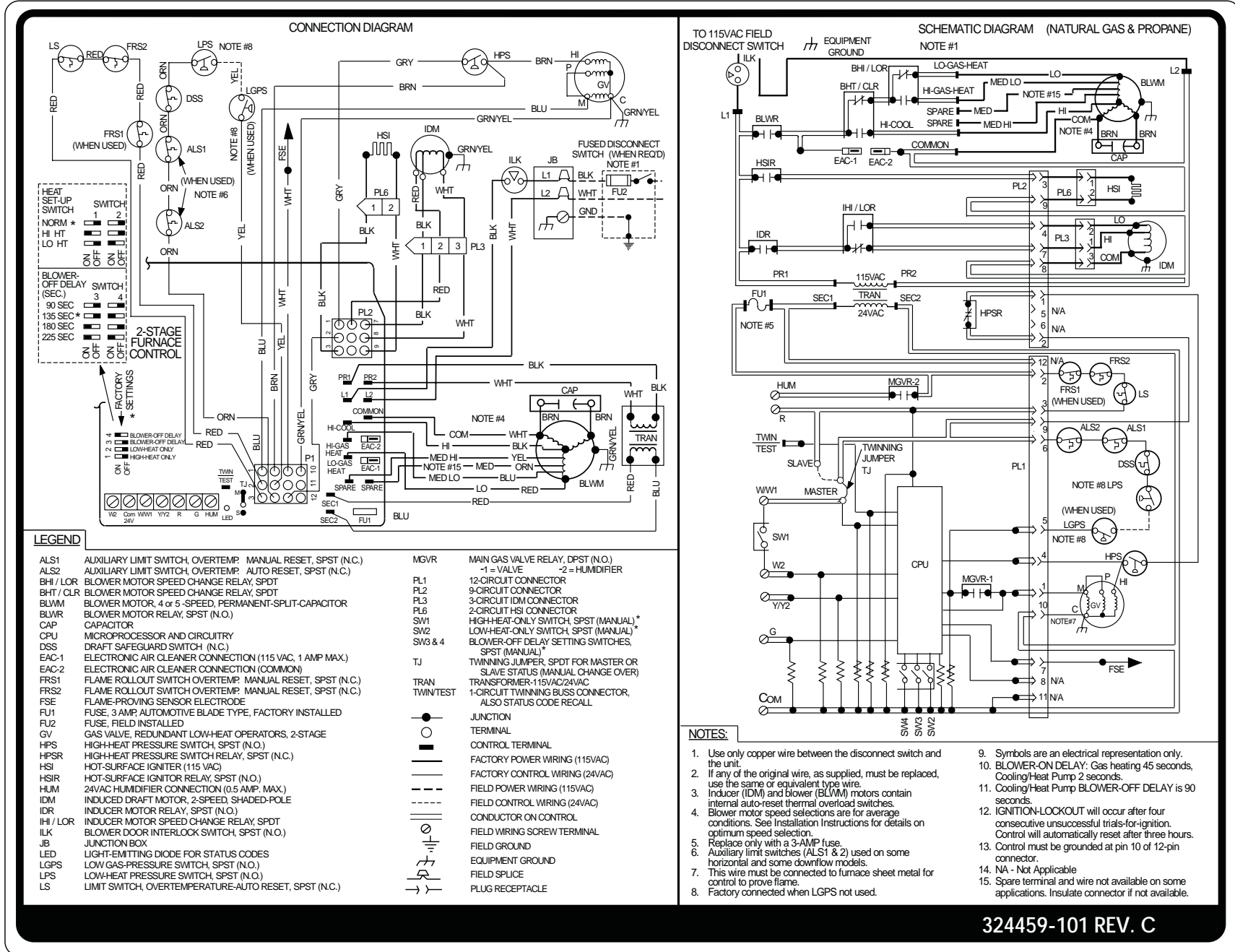

324459-101 REV. C

Fig. 12—Unit Wiring Diagram

SERVICE

If status code recall is needed, do not remove power or blower door. Briefly remove and then reconnect one main limit wire to display stored status code.

- | | |
|-----------------|--|
| LED CODE | STATUS |
| CONTINUOUS OFF | - Check for 115VAC at L1 and L2, and 24VAC at SEC1 and SEC2 |
| CONTINUOUS ON | - Control has 24VAC power. |
| RAPID FLASHING | - Line voltage (115VAC) polarity reversed. If twinned, refer to twinning kit instructions. |

Each of the following status codes is a two-digit number with the first digit determined by the number of short flashes and the second digit by the number of long flashes.

- 11 NO PREVIOUS CODE Stored status codes are erased when power (115VAC or 24VAC) to control is interrupted or 48 hours after each fault is cleared.
- 12 BLOWER ON AFTER POWER UP (115VAC or 24VAC)- Blower runs for 90 seconds, if unit is powered up during a call for heat (R-W closed).
- 13 LIMIT OR FLAME ROLL-OUT SWITCH LOCKOUT Control will auto reset after three hours. Reset switch or replace fuse link. Refer to #33.
- 14 IGNITION LOCKOUT -Control will auto-reset after three hours. Refer to #34.
- 21 GAS HEATING LOCKOUT -Control will NOT auto-reset.
Check for: - Mis-wired gas valve - Defective control (valve relay)
- 22 ABNORMAL FLAME-PROVING SIGNAL- Flame is proved while gas valve is de-energized. Inducer will run until fault is cleared. Check for:
- Leaky gas valve - Stuck-open gas valve
- 23 PRESSURE SWITCH DID NOT OPEN Check for:
- Obstructed pressure tubing - Pressure switch stuck closed.
- 24 SECONDARY VOLTAGE FUSE IS OPEN Check for: - Short-circuit in secondary voltage (24VAC) wiring
- 31 HIGH-HEAT PRESSURE SWITCH OR RELAY DID NOT CLOSE OR REOPENED
Check for: -Control relay may be defective - Refer to #32
- 32 LOW-HEAT PRESSURE, DRAFT SAFEGUARD (when used) , AUX-LIMIT (when used*) SWITCH DID NOT CLOSE OR REOPENED (DOWNFLOW ONLY*) If open longer than five minutes, inducer shuts off for 15 minutes before retry. If it opens after trial for ignition period, blower will come on for 90 second recycle delay. Check for:
* - Defective blower motor or capacitor - Restricted vent
- Proper vent sizing - Low inducer voltage (115VAC)
- Disconnected or obstructed pressure tubing - Excessive wind
- Defective inducer motor - Defective pressure switch
- Inadequate combustion air supply
- 33 LIMIT OR FLAME ROLL-OUT SWITCH IS OPEN Open longer than three minutes, code changes to #13. Flame roll-out switch requires manual reset. Check for:
- Dirty filter or restricted duct system. - Loose blower wheel.
- Defective blower motor or capacitor. - Defective switch or connections.
- Inadequate combustion air supply (Flame roll-out switch or fuse link open).
- Open flame roll-out switch, or fuse link. Manual reset or replace.
- 34 IGNITION PROVING FAILURE Control will try three more times before lockout #14 occurs. If flamesignal is lost after trial for ignition period, blower will come on for 90 second recycle delay. Check for:
- Gas valve defective or gas valve turned off.
- Oxide buildup on flame sensor (clean with fine steel wool).
- Proper flame sense current (.5 microamps D.C. min., 4.0 - 6.0 nom. in HIGH HEAT).
- Green wire MUST be connected to furnace sheet metal.
- Flame sensor must be ungrounded. - Manual valve shut-off.
- Defective hot surface ignitor - Control ground continuity.
- Inadequate flame carryover or rough ignition. - Low inlet gas pressure.
- 43 LOW-HEAT PRESSURE, DRAFT SAFEGUARD (when used) , OR AUX-LIMIT (when used*) SWITCH OPEN WHILE HIGH-HEAT PRESSURE SWITCH IS CLOSED Check for:
- Pressure switch stuck open
- Disconnected or obstructed pressure tubing - Refer to #32 and #33
- 45 REPLACE CONTROL

COMPONENT TEST

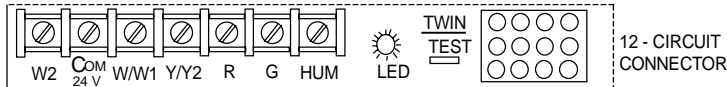

To initiate the component self-test sequence, shut off the room thermostat or disconnect the "R" thermostat lead. Briefly short the TWIN/TEST terminal to the Com24V terminal. Status LED will turn off. **NON-CONDENSING FURNACE:** The control will turn ON the inducer motor low speed, then high speed and remain on high speed for the entire test. The other components will be ON for 7 to 15 seconds: Hot surface ignitor, Low heat blower speed, High heat blower speed, High cooling blower speed. **CONDENSING FURNACE:** The inducer motor will start in high speed and remain on high speed until the end of the test, then shift to low speed for 7 to 15 seconds. All other components will be tested in the same sequence as the NON-CONDENSING.

320893-101 REV. E

Fig. 13—Service Label

NOTES:

1. Refer to information label on blower compartment door for procedure for use of LED status codes and problem solving suggestions.
2. LED indicator is viewed through window on blower compartment door.
3. If 115-vac power is energized or interrupted during a call for heat, the indoor blower will run for 90 sec before a gas heating cycle begins – **Code 12**.
4. After replacing any component, verify correct operating sequence.

TROUBLESHOOTING GUIDE**WARNING****ELECTRICAL SHOCK HAZARD**

ONLY QUALIFIED AND TRAINED SERVICE PERSONNEL SHOULD PERFORM THIS PROCEDURE

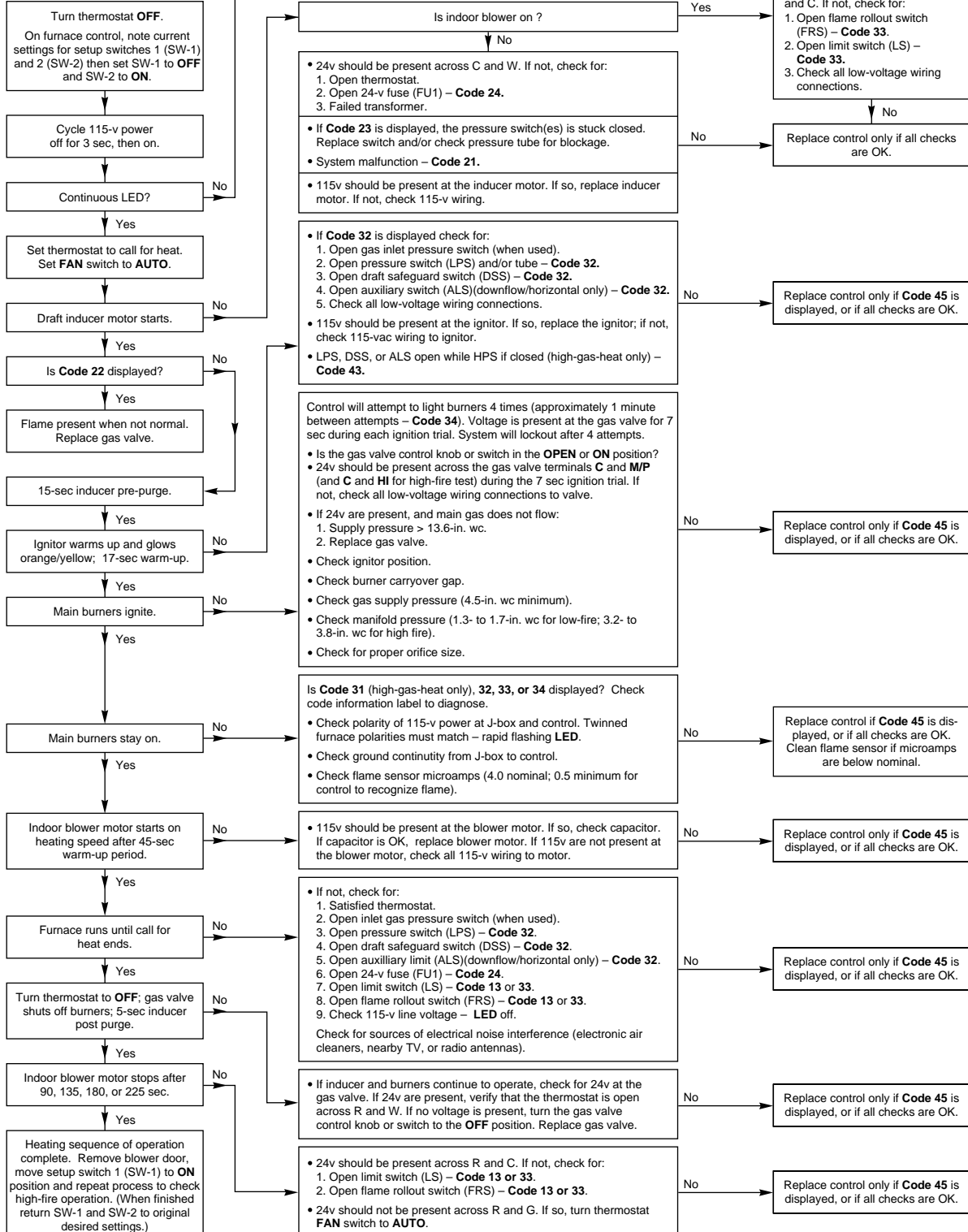
START

SERVICE TRAINING

Packaged Service Training programs are an excellent way to increase your knowledge of the equipment discussed in this manual, including:

- Unit Familiarization
- Maintenance
- Installation Overview
- Operating Sequence

A large selection of product, theory, and skills programs is available, using popular video-based formats and materials. All include video and/or slides, plus companion book.

Classroom Service Training plus "hands-on" the products in our labs can mean increased confidence that really pays dividends in faster troubleshooting, fewer callbacks. Course descriptions and schedules are in our catalog.

CALL FOR FREE CATALOG 1-800-962-9212

Packaged Service Training

Classroom Service Training

A94328