

## Installation Instructions



HRVXXLHB Unit

A05260

### INTRODUCTION

The Heat Recovery Ventilator (HRV) is used to exchange indoor stale air with outside fresh air. The HRV unit is equipped with a special heat recovery core which transfers sensible heat between the fresh incoming air and stale exhaust air.

It is required to locate the HRV in a conditioned space. Special attention should be given to condensate drain, duct application, balancing the HRV, and locating unit for easy access and routine maintenance. The cross-flow design core allows entering and leaving air streams to transfer heat energy without mixing.

**NOTE:** Read the entire instruction manual before starting the installation.

### SAFETY CONSIDERATIONS

Improper installation, adjustment, alteration, service, maintenance, or use can cause explosion, fire, electrical shock, or other conditions which may cause death, personal injury or property damage. Consult a qualified installer, service agency or your distributor or branch for information or assistance. The qualified installer or agency must use factory-authorized kits or accessories when modifying this product. Refer to the individual instructions packaged with the kits or accessories when installing.

Follow all safety codes. Wear safety glasses, protective clothing, and work gloves. Have a fire extinguisher available. Read these instructions thoroughly and follow all warnings and cautions included in literature and attached to the unit. Consult local building codes and the current edition of the National Electrical Code (NEC) NFPA 70.

In Canada, refer to the current editions of the Canadian Electrical Code CSA C22.1.

Recognize safety information. When you see this symbol  on the unit and in instructions or manuals, be alert to the potential for personal injury. Understand the signal words **DANGER**, **WARNING**, and **CAUTION**. These words are used with the safety-alert symbol. **DANGER** identifies the most serious hazards, which **will** result in severe personal injury or death. **WARNING** signifies hazards, which **could** result in personal injury or death. **CAUTION** is used to identify unsafe practices, which **may** result in minor personal injury or product and property damage. **NOTE** is used to highlight suggestions which **will** result in enhanced installation, reliability, or operation.



These products earned the ENERGY STAR® by meeting strict energy efficiency guidelines set by Natural Resources Canada and the US EPA. They meet ENERGY STAR requirements only when used in Canada.

## TYPICAL INSTALLATIONS

**NOTE:** Installation may vary according to the model number and the position; normal or reverse in which the unit is installed.

There are three common installation methods.

### Fully Ducted System

(Primarily for homes with radiant hot water or electric baseboard heating.) See Fig. 1.

Moist, stale air is exhausted from the high humidity areas in the home, such as bathrooms, kitchen and laundry room.

Fresh air is supplied to bedrooms and principal living areas. If required, bathroom fans and a range hood may be used to better exhaust stale air.

Homes with more than one level require at least one exhaust register at the highest level.

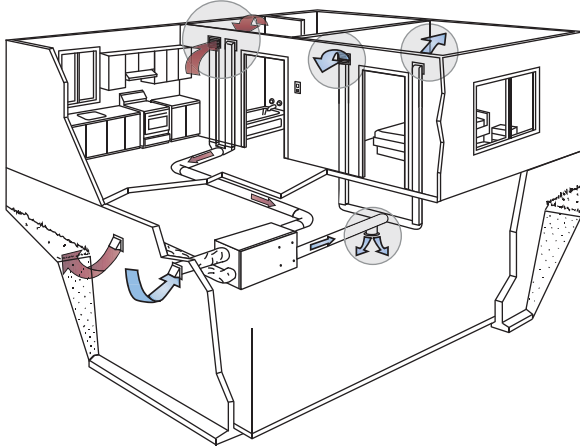

A12281

**Fig. 1 - Fully Ducted System**

### Exhaust Ducted System (Source Point Ventilation)

(For homes with forced air heating.) See Fig. 2.

Moist, stale air is exhausted from the high humidity areas in the home, such as bathrooms, kitchen and laundry room. Fresh air is supplied to the cold air return or the supply duct of the furnace.

Homes with more than one level require at least one exhaust register at the highest level.

**NOTE:** For this type of installation, it is not essential that the furnace blower runs when the unit is in operation, but we recommend it.

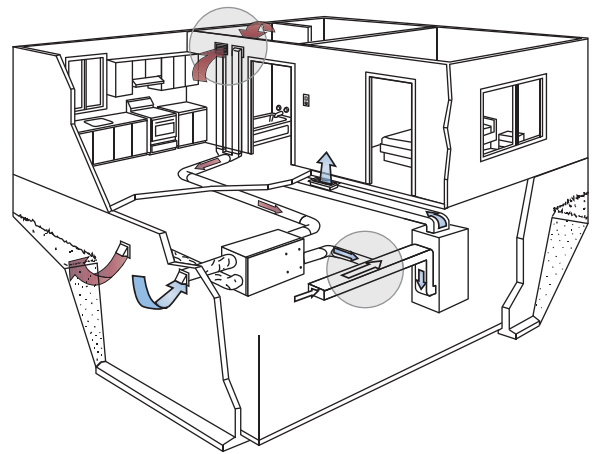

A12282

**Fig. 2 - Exhaust Ducted System**

### Simplified (Volume Ventilation)

(For homes with forced air heating.) See Fig. 3.

Fresh air and exhaust air flow through the furnace ducts, which simplifies the installation.

The use of bathroom fans and a range hood is suggested to exhaust stale air.

**NOTE:** For this type of installation, the furnace blower must be running when the unit is in operation.

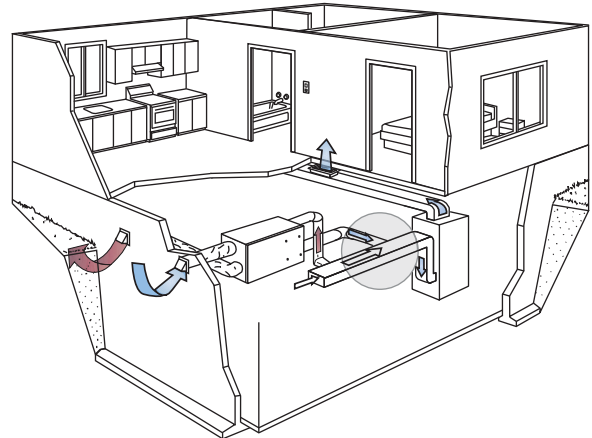

A12283

**Fig. 3 - Fully Ducted System**

## COMPONENT DESCRIPTION

The following listed items are components of HRVXXLHB. See Fig.4.

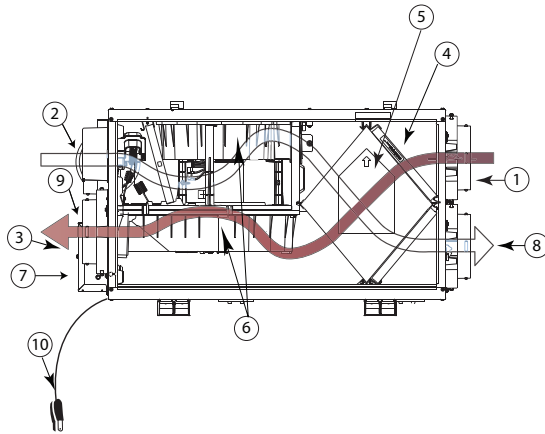

A12284

**Fig. 4 - Component Location**

1. Stale air return from building connected to return-air duct system.
2. Fresh-air intake connected to outdoor air inlet hood.
3. Exhaust-air connected to outdoor air exhaust hood.
4. Mechanical filters trap dust contained in the air.
5. Heat recovery core is a cross-flow type. The core transfers heat between the 2 air streams. See Fig. 5 and Fig. 6.
6. Blowers bring in fresh-air from outside and exhaust stale-air to outside.
7. Electronic control circuit ensures proper unit operation.
8. Fresh-air supply from HRV connected to return-air duct of forced-air system.
9. Terminal connector block for wiring wall and timer controls.
10. Electrical cord connects to standard 115V outlet.

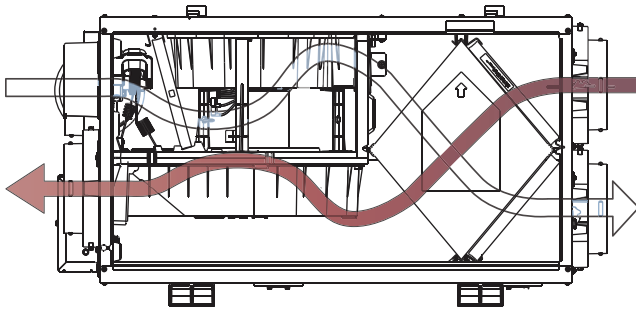

A12285

**Fig. 5 - Air Distribution (Normal Operation)**

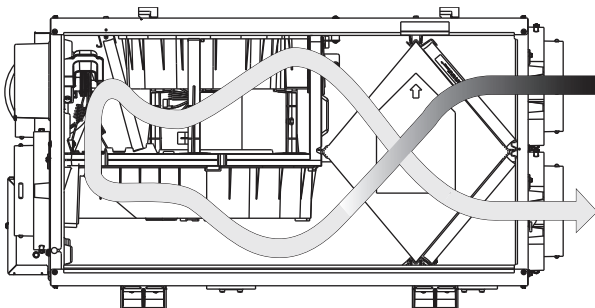

A12286

**Fig. 6 - Air Distribution (Defrost Mode)**

## UNIT INSTALLATION

### LOCATION

#### Inspect Equipment

Move carton to final installation location. Remove the HRV from carton taking care not to damage unit. Remove all packaging and inspect unit for damage. Remove parts bag from inside unit. File claim with shipping company if shipment is damaged or incomplete.

#### Select Location

The HRV **should be located in a conditioned space** and in close proximity to a fused power source. It should be easily accessible for routine maintenance.

If HRV is installed independent of a forced-air system, unit should be located near the center of the air distribution system. If HRV is installed in conjunction with a forced-air system, unit should be located next to (or close to) the indoor equipment.

### ⚠ CAUTION

#### UNIT DAMAGE HAZARD

Failure to follow this caution may result in equipment damage or improper operation.

Do not install HRV in a corrosive or contaminated atmosphere.

### ⚠ WARNING

#### ELECTRICAL SHOCK / FIRE HAZARD

Failure to follow this warning could result in property or unit damage.

Do not use an extension cord as a power source for operating the HRV.

### ⚠ CAUTION

#### UNIT DAMAGE HAZARD

Failure to follow this caution may result in reduced unit efficiency, capacity or unit life.

**DO NOT** use HRV during construction of a house or when sanding drywall. This type of dust may damage system.

#### Mount Unit

The HRV can be suspended from floor joists using chains and 4 springs. Attach metal hanging bracket to all 4 sides of cabinet (see Fig. 7). Unit should always be installed as level as possible.

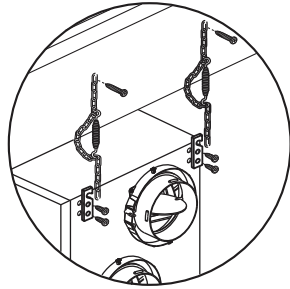
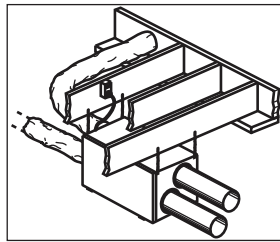

A12287

Fig. 7 - Chain Spring Installation

### Independent System Application

In the absence of a forced-air system and a typical duct system layout, the HRV can be applied as an independent or stand alone unit. To ensure comfort, this type of application involves running both fresh-air and return-air registers (or stale-air pickup registers) throughout the home.

**⚠ WARNING**

**CARBON MONOXIDE POISONING HAZARD**

Failure to follow this warning could result in personal injury or death.

Do not install return-air registers (or stale-air pickup registers) in same room as gas furnace or water heater.

Fresh-air registers are normally located in bedrooms, dining room, living room, and basement. It is recommended that registers be placed 6 to 12 in. (152 to 305 mm) from the ceiling on an interior wall and airflow directed toward ceiling. If registers are floor installed, airflow should be directed toward the wall.

Return-air (or stale-air pickup registers) are normally located to draw from kitchen, bathroom, basement, or other rooms where stale-air can exist.

Proper size and type of registers must be used to minimize pressure drop. The velocity of airflow through register should not be above 400 ft/minute.

### Calculating the Duct Size

Use the table below to ensure that the ducts you intend to install will be carrying air flows at or under the recommended values. Avoid installing ducts that will have to carry air flows near the maximum values and never install a duct if its air flow exceeds the maximum value.

#### Example of Calculation

**PROBLEM:** My installation requires two exhaust registers (one for the kitchen, one for the bathroom). I will connect these registers to a main duct which will connect to the unit (high speed performance value of 140 cfm). What size of duct should I use for the main exhaust duct and for the two end branches leading to the registers? See Fig. 8.

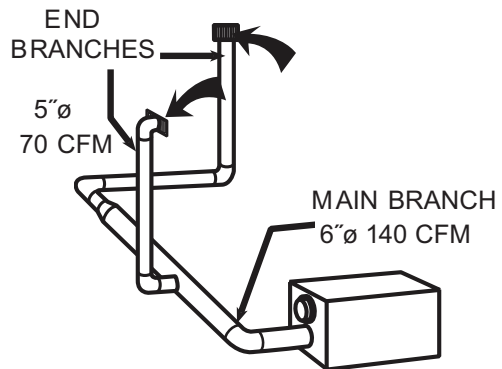

A12288

Fig. 8 - Main and End Branches

**SOLUTION:** Simplified method. (For a more detailed method of calculating duct size refer to the ASHRAE or HRAI HANDBOOK).

**Main duct:** Table above indicates a 6-in Ø duct: Recommended air flow: 120 cfm; maximum air flow: 180 cfm. The high speed air flow of 140 cfm is close enough to the recommended value (120) and far enough away from the maximum value (180). Therefore a 6-in Ø duct or larger is an appropriate choice for the main exhaust duct.

**End branches:** Each end branch will have to transport an air flow of 70 cfm (140 divided by 2). Table above indicates a 5-in Ø duct: Recommended air flow: 75 cfm; maximum air flow: 110 cfm. The high speed air flow of 70 cfm is close enough to the recommended value (75) and far enough away from the maximum value (110). Therefore a 5-in Ø duct or larger is an appropriate choice for the 2 end branches.

**NOTE:** A 4-in Ø duct would have been too small because the maximum acceptable value for a 4-in Ø duct is 60 cfm.

DUCT DIAMETER	RECOMMENDED AIR FLOW			MAXIMUM AIR FLOW		
	cfm	L/s	M <sup>3</sup> /H	cfm	L/s	M <sup>3</sup> /H
4- in (102 mm)	40 cfm	19 L/s	68 M <sup>3</sup> /H	60 cfm	28 L/s	102 M <sup>3</sup> /H
5- in (127 mm)	75 cfm	35 L/s	127 M <sup>3</sup> /H	110 cfm	52 L/s	187 M <sup>3</sup> /H
6- in (152 mm)	120 cfm	57 L/s	204 M <sup>3</sup> /H	180 cfm	85 L/s	306 M <sup>3</sup> /H
7- in (178 mm)	185 cfm	87 L/s	314 M <sup>3</sup> /H	270 cfm	127 L/s	459 M <sup>3</sup> /H
8- in (203 mm)	260 cfm	123 L/s	442 M <sup>3</sup> /H	380 cfm	179 L/s	645 M <sup>3</sup> /H

**NOTE:** Examples use imperial measures. The same calculation applies to metric measures.

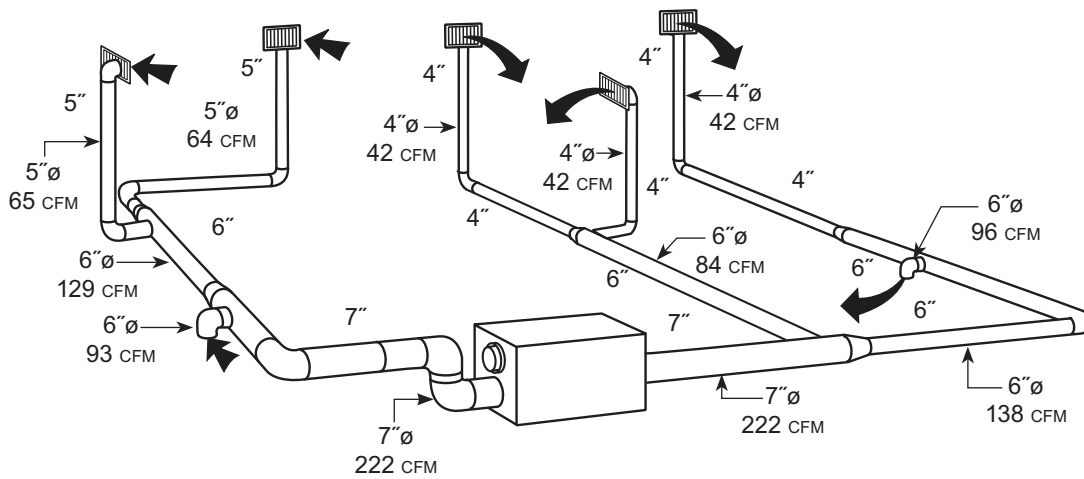

Fig. 9 - Example of a design for a fully ducted system for a unit having a high speed performance of 222 cfm

A12289

### Installing the Ductwork and the Registers

#### ⚠ WARNING

##### PERSONAL INJURY HAZARD

Failure to follow this caution may result in personal injury.

Never install a stale air exhaust register in a room where there is a combustion device, such as a gas furnace, a gas water heater or a fireplace.

#### ⚠ CAUTION

##### PROPERTY DAMAGE HAZARD

Failure to follow this caution may result in property damage.

The ductwork is intended to be installed in compliance with all local and national codes that are applicable.

### FRESH AIR DISTRIBUTION:

#### ⚠ WARNING

##### PROPERTY DAMAGE HAZARD

Failure to follow this caution may result in property damage.

When performing duct connection to the furnace, installation must be done in accordance with all applicable codes and standards. Please refer to your local building code.

#### ⚠ CAUTION

##### PROPERTY DAMAGE HAZARD

Failure to follow this caution may result in property damage.

When performing duct connection to the furnace supply duct, this duct must be sized to support the additional airflow produced by the ERV/HRV. Also, use a metal duct. It is recommended that the ERV/HRV is running when the furnace is in operation in order to prevent backdrafting inside ERV/HRV.

### Fully Ducted System

#### STALE AIR EXHAUST DUCTWORK:

- Install registers in areas where contaminants are produced: Kitchen, bathrooms, laundry room, etc.
- Install registers 6 to 12 inches (152 to 305 mm) from the ceiling on an interior wall OR install them in the ceiling.
- Install the kitchen register at least 4 feet (1.2 m) from the range.
- If possible, measure the velocity of the air flowing through the registers. If the velocity is higher than 400 ft/min. (122 m/min), then the register type is too small. Replace with a larger one.

#### FRESH AIR DISTRIBUTION DUCTWORK:

- Install registers in bedrooms, dining room, living room and basement.
- Install registers either in the ceiling or high on the walls with air flow directed towards the ceiling. (The cooler air will then cross the upper part of the room, and mix with room air before descending to occupant level.)
- If a register must be floor installed, direct the air flow up the wall.

### Exhaust Ducted System

#### STALE AIR EXHAUST DUCTWORK:

Same as for Fully Ducted System above.

There are two methods for connecting the unit to the furnace:

#### METHOD 1: SUPPLY SIDE CONNECTION

- Cut an opening into the furnace supply duct at least 18 inches (0.5 m) from the furnace.
- Connect this opening to the fresh air distribution port of the HRV/ERV (use metal duct). See Fig. 10.

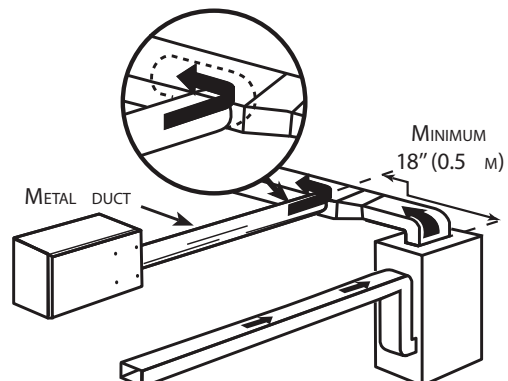

Fig. 10 - Supply Side Connection

A12290

- Make sure that the HRV/ERV duct forms an elbow inside the furnace ductwork.
- If desired, interlock (synchronize) the furnace blower operation with the HRV/ERV operation.

**METHOD 2: RETURN SIDE CONNECTION**

- Cut an opening into the furnace return duct not less than 10 feet (3.1 m) from the furnace (A+B).
- Connect this opening to the fresh air distribution port of the HRV/ERV. See Fig. 11.

**NOTE:** For Method 2, it is not essential that the furnace blower runs when the unit is in operation, but we recommend it. If desired, synchronize the furnace blower operation with the HRV/ERV operation.

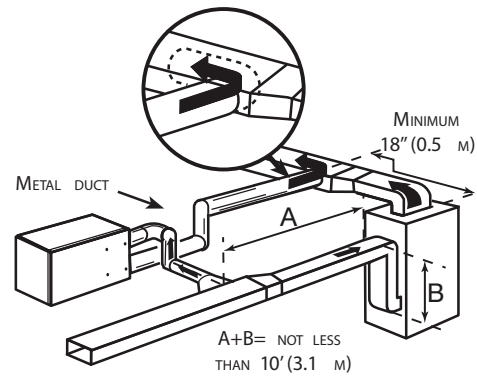
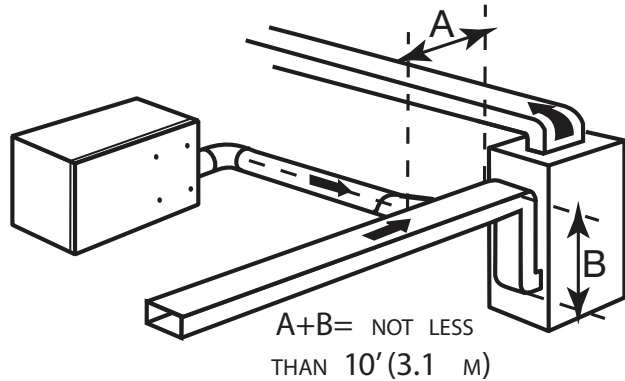

**Fig. 12 - Method 1: Return-Supply**

A12292

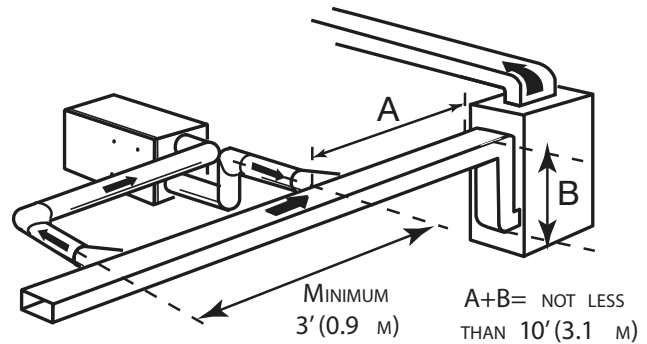

**Fig. 13 - Method 2: Return-Return**

A12293

**Simplified Installation**

**⚠ WARNING**

**PROPERTY DAMAGE HAZARD**

Failure to follow this caution may result in property damage.

When performing duct connection to the furnace, installation must be done in accordance with all applicable codes and standards. Please refer to your local building code.

**⚠ CAUTION**

**PROPERTY DAMAGE HAZARD**

Failure to follow this caution may result in property damage.

When performing duct connection to the furnace supply duct, this duct must be sized to support the additional airflow produced by the ERV/HRV. Also, use a metal duct. It is recommended that the ERV/HRV is running when the furnace is in operation in order to prevent backdrafting inside ERV/HRV.

There are two methods for connecting the unit to the furnace ducts. See Fig.12 and 13.

**STALE AIR INTAKE:**

- Cut an opening into the furnace return duct not less than 10 feet (3.1 m) from the furnace.
- Connect this opening to the stale air intake port of the HRV/ERV (as shown above).

**FRESH AIR DISTRIBUTION:**

Same instructions as for Method 1 or Method 2.

**IMPORTANT:** If using Method 2, make sure the furnace blower operation is synchronized with the unit operation!

For Method 2 (Return-Return), make sure there is a distance of at least 3 feet (0.9 m) between the 2 connections to the furnace duct.

**NOTE:** For Method 1, it is not essential to synchronize the furnace blower operation with the HRV/ERV operation, but we recommend it.

**Connecting the ducts to the unit**

**IMPORTANT:** If ducts have to go through an unconditioned space (e.g.: attic), always use insulated ducts.

**INSULATED FLEXIBLE DUCTS**

Use the following procedure for connecting the insulated flexible duct to the ports on the unit (exhaust to outside and fresh air from outside).

1. Pull back the insulation to expose the flexible duct.
2. Install good quality aluminum duct tape to prevent potential water leakage from duct.
3. Attach the flexible duct to the port using tie wrap.
4. Pull the insulation over the joint and tuck it between the inner and outer rings of the double collar.

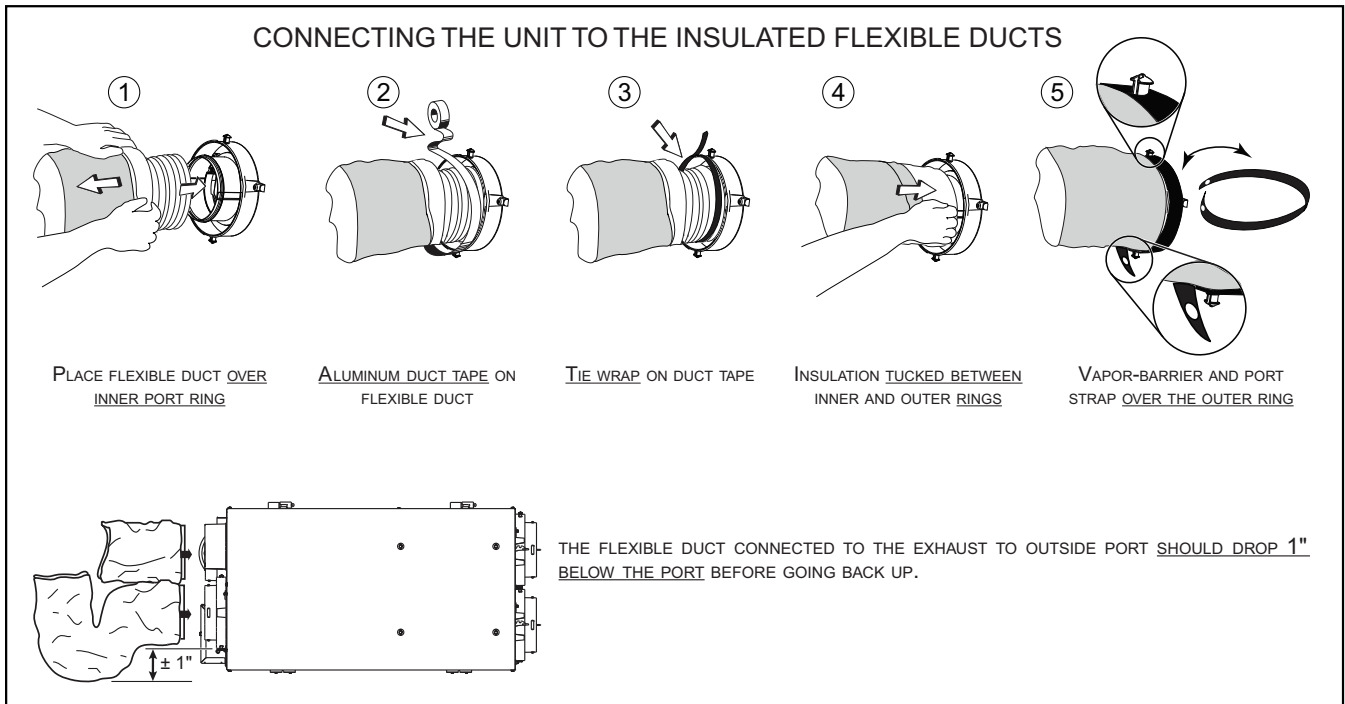

A12562

**Fig. 14 - Rigid Ducts**

5. Pull down the vapor barrier (shaded part in Fig. 14 over the outer ring to cover it completely. Fasten in place the vapor barrier using the port strap (included in unit parts bag). To do so, insert one collar pin through vapor barrier and first strap hole, then insert the other collar pin through vapor barrier and center strap hole and close the loop by inserting the first collar pin in the last strap hole.

**IMPORTANT:** Make sure the vapor barrier on the insulated ducts does not tear during installation to avoid condensation within the ducts.

Use duct tape to connect the rigid ducts to the ports.

**IMPORTANT:** Do not use screws to connect rigid ducts to the ports.

Make sure that both balancing dampers are left in a fully open position before connecting the ducts to these ports (**Fresh air to building port** and **Exhaust air from building port** as shown in Fig. 15).

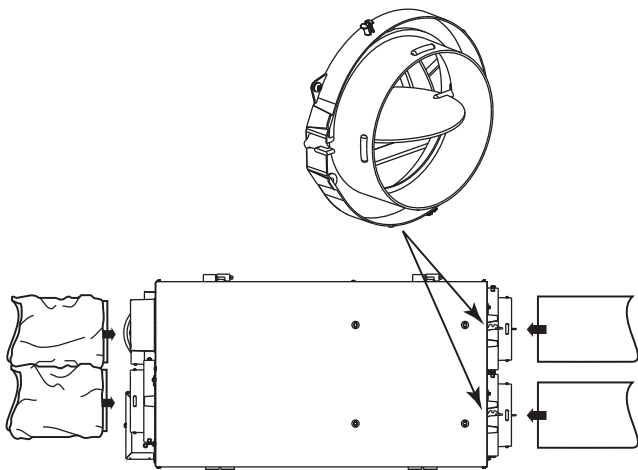

A12295

**Fig. 15 - Opened Balancing Dampers**

### Installing the Exterior Hoods

Choose an appropriate location for installing the exterior hoods:

- At a minimum distance of 6 feet (1.8 m) between the hoods to avoid cross-contamination
- At a minimum distance of 18 inches (457 mm) from the ground

**IMPORTANT:** Make sure the intake hood is at least 6 feet (1.8 m) away from any of the following:

- Dryer exhaust, high efficiency furnace vent, central vacuum vent
- Gas meter exhaust, gas barbecue-grill
- Any exhaust from a combustion source
- Garbage bin and any other source of contamination

Refer to Fig. 16 For connecting the insulated duct to the hoods. An "Anti-Gust Intake Hood" should be installed in regions where a lot of snow is expected to fall.

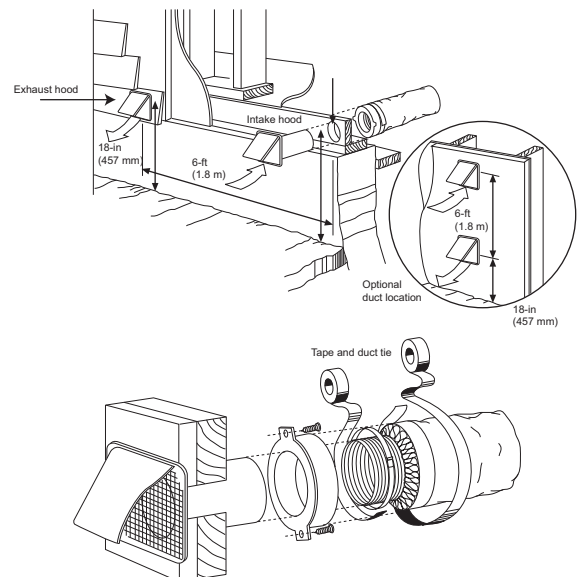

A11206

**Fig. 16 - Exterior Hoods**

## Connecting the Drain (HRV Units Only)

Cut 2 sections of the plastic tube, about 12-in (305 mm) long, and attach them to each inner drain fitting, located under the unit. Join both short sections to the “T” junction and main tube as shown in Fig. 17.

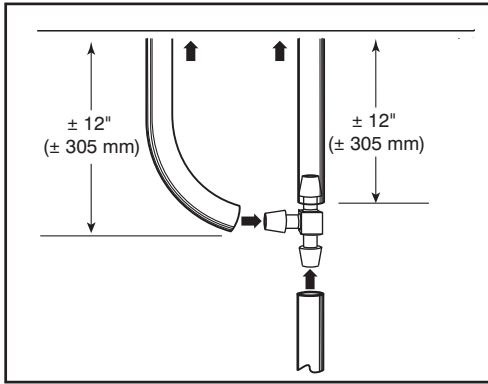

A12297

Fig. 17 - Connecting the drain

Make a water trap loop in the tube to prevent the unit from drawing unpleasant odors from the drain source. Make sure this loop is located OVER the “T” as shown in Fig. 18. Run the tube to the floor drain or to an alternative drain pipe or pail.

**IMPORTANT:** If using a pail to collect water, locate the tube end approximately 1-in from the top of the pail in order to prevent water from being drawn back up into the unit.

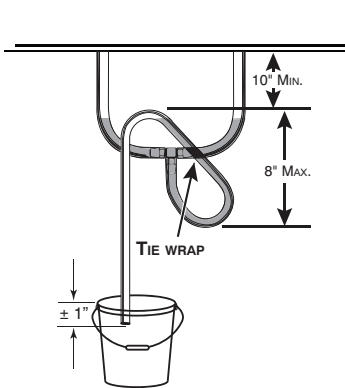

A12566

Fig. 18 - Water Trap

Insert both drain plugs (included in parts bag) in alternate drain fittings located on top of the unit. See Fig. 19.

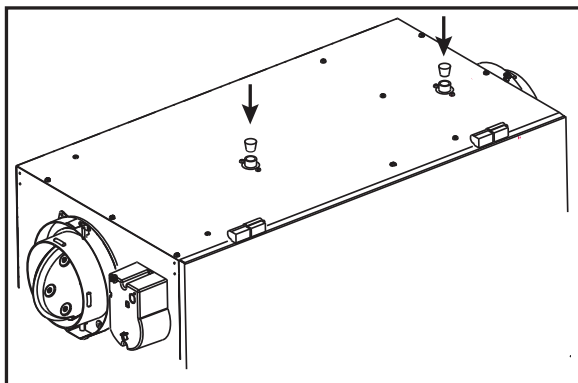

A12299

Fig. 19 - Drain Plugs

## Integrated Control

All units are equipped with an integrated control, located in front of the electrical compartment. See Fig. 20. Use the push button (1) to control the unit. The LED (2) will then show on which mode the unit is in.

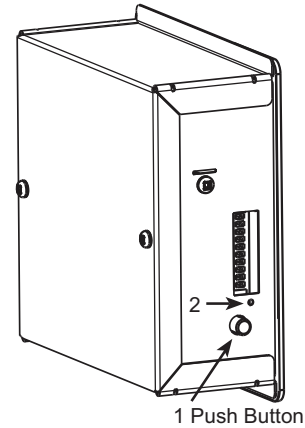

A12300

Fig. 20 - Integrated Control

### NOTES:

1. The integrated control must be turned OFF to use an optional main control.
2. If an optional auxiliary control is used, if activated, this auxiliary control will override the optional main control.

Refer to table below to see how to operate the unit using its integrated control.

PRESS ON PUSH BUTTON	LED COLOR	RESULTS
Once	Amber	Unit is on Low Speed
Twice	Green	Unit is on High Speed
Three Times	No Light	Unit is OFF

If a problem occurs during the unit operation, its integrated control LED (2) will blink. The color of the blinking light depends on the type of error detected. Refer to Troubleshooting Table for further details.

### Boot Sequence

The unit boot sequence is similar to a personal computer boot sequence. Each time the unit is plugged after being unplugged, or after a power failure, the unit will perform a 30-second booting sequence before starting to operate. During the booting sequence, the integrated control LED will light GREEN (unit set in normal defrost) or AMBER (unit set in extended defrost) for 5 seconds, and then will shut off for 2 seconds. After that, the LED will light RED for the rest of the booting sequence. During this RED light phase, the unit is checking and resetting the motorized damper position. Once the motorized damper position completely set, the RED light turns off and the booting sequence is done.

**NOTE:** No command will be taken until the unit is fully booted.

### Setting Extended Defrost

The unit is factory set to normal defrost. In cold region, it may be necessary to setup extended defrost. During the first 5 seconds of booting sequence, while the integrated control LED is GREEN, press on push button until the LED turns AMBER (about 3 seconds). See Fig. 21.



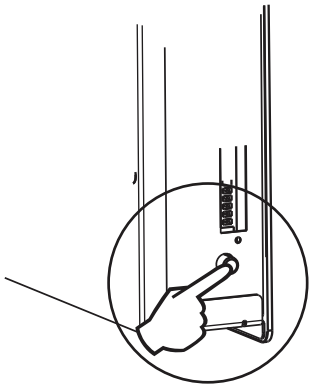

**Fig. 21 - Setting Extended Defrost**

A12301

**IMPORTANT:** When installed in reverse position (upside down) in a cold region where outside temperature could drop below -20°C (-4°F) for more than 5 days in a row, the unit must always be set in extended defrost.

**Electrical Connection to Optional Wall Control**

For more convenience, this unit can also be controlled using an optional main wall control.

**IMPORTANT:** Always disconnect the unit before making any connections. Failure in disconnecting power could result in electrical shock or damage of the wall control or electronic module inside the unit.

**IMPORTANT:** Never install more than one optional main wall control per unit. Make sure that the wires do not short-circuit between themselves or by touching any other components on the wall control. Avoid poor wiring connections. To reduce electrical interference (noise) potential, do not run wall control wiring next to control contactors or near light dimming circuits, electrical motors, dwelling/building power or lighting wiring, or power distribution panel.

Use the terminal connector included in the installation kit to perform the electrical connection for main and optional wall controls. Check if all wires are correctly inserted in their corresponding holes in the terminal block. (A wire is correctly inserted when its orange receptacle is lower than another one without wire. Refer to Fig. 22, wire A is correctly inserted, but not wire B.)

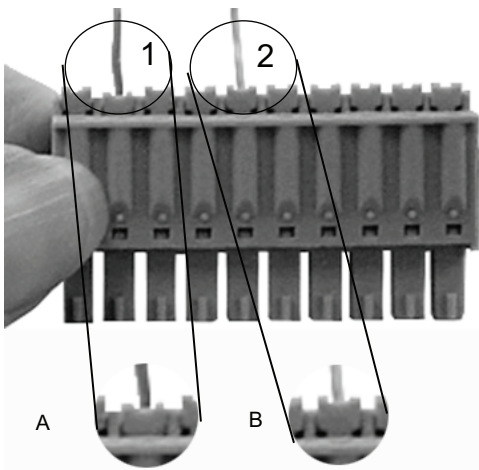
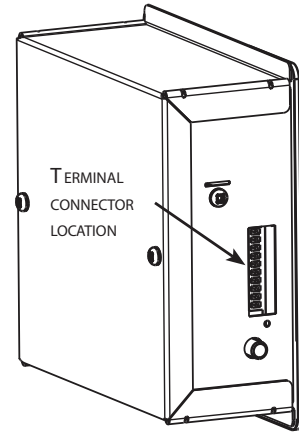

**Fig. 22 - Terminal Connector**

A11211

Once the wall control(s) connections have been made, insert the terminal connector in the electrical compartment front face.

**NOTE:** For information about the operation of the wall controls, refer to the user guide.



**Fig. 23 - Terminal Connector**

A12296

Electrical connection to OneTouch (all units).

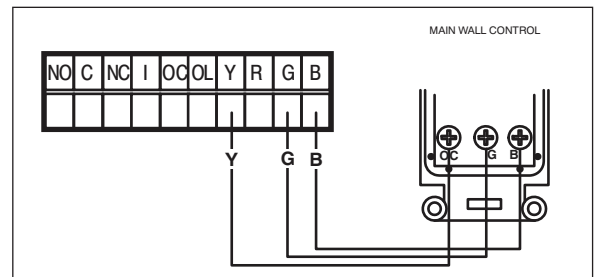

**Fig. 24 - OneTouch Connection**

A12302

Electrical Connection to main wall control (all units).

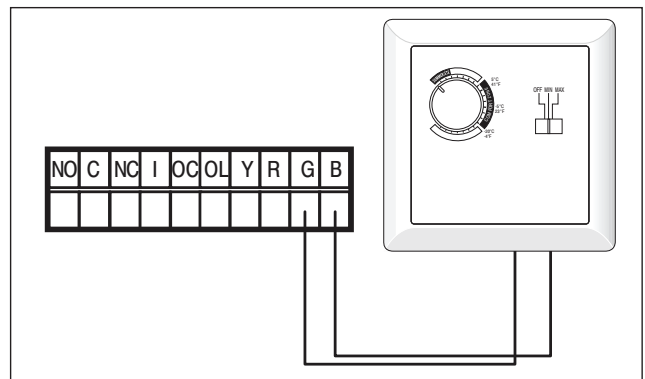

**Fig. 25 - Main Wall Control**

A12303

## Electrical Connection to Optional Auxiliary Wall Controls

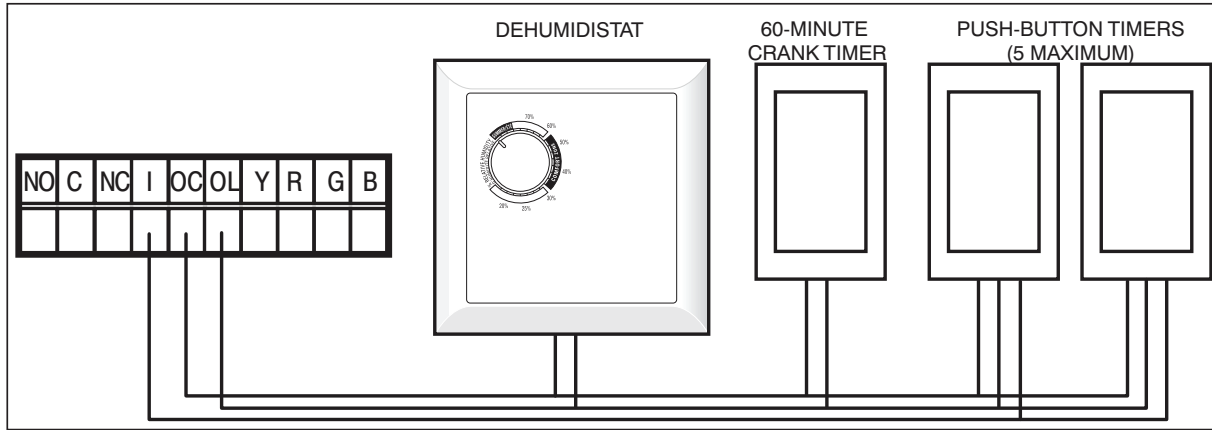

A12304

**Fig. 26 - Optional Auxiliary Wall Controls**

**NOTE:** If an optional auxiliary wall control is activated and then, the Dehumidistat is being activated, this one will override the auxiliary wall control commands.

**Table 1 – Basic Control**

MODE	OPERATION	DAMPER POSITION	FAN SPEED
Off	Off	Closed to outside	Off
Low	Air exchange with outside	Open to outside	Low
High	Air exchange with outside	Open to outside	High

**Table 2 – OneTouch Push Button Control**

MODE	OPERATION	DAMPER POSITION	FAN SPEED
Off	Off	Closed to outside	Off
Low	Air exchange with outside	Open to outside	Low
Intermittent 40 min off 20 min exchange low speed	Air exchange with outside	Open to outside 20 min Closed 40 min	Low Off
High	Air exchange with outside	Open to outside	High

**Table 3 – Compatible Optional Auxiliary Wall Controls According to Unit**

DEHUMIDISTAT
60- minute crank timer
20- minute lighted push- button switch (5 max.)

**Table 4 – Standard Control**

MODE	DEHUMIDISTAT POSITION	OPERATION	DAMPER POSITION	FAN SPEED	ON LED	AIR EXCHANGE LED
Off	Any	Off	Closed to outside	Off	Off	Off
Low	Satisfied	Air exchange with outside	Open to outside	Low	On	On
	Call for dehumidification			High		On
Intermittent 40 min off 20 min exchange low speed	Satisfied	Off 40min Low 20 min	Closed to outside/ open	Off/Low	On	Off
	Call for dehumidification	Air exchange with outside	Open to outside	High		On

Standard furnace interlock wiring

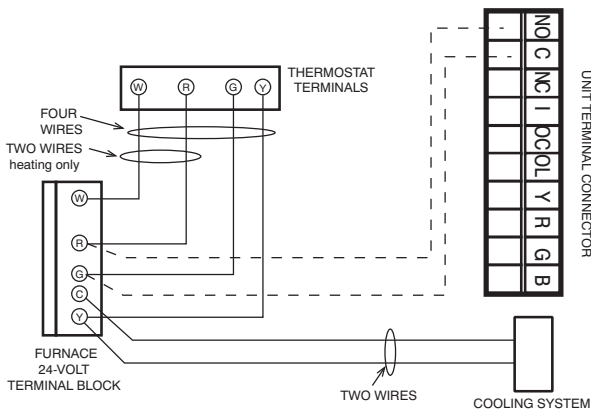

Alternate furnace interlock wiring

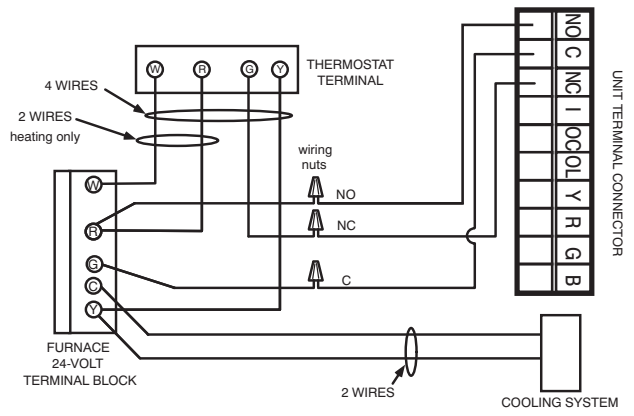

Fig. 27 - Interlock Wiring

A11215

## ELECTRIC CONNECTION TO THE FURNACE

**IMPORTANT:** Never connect a 120-volt AC circuit to the terminals of the furnace interlock (standard wiring). Only use the low voltage class 2 circuit of the furnace blower control.

### For a furnace connected to a cooling system

On some older thermostats, energizing the “R” and “G” terminals at the furnace has the effect of energizing “Y” at the thermostat and thereby turning on the cooling system. If you identify this type of thermostat, you must use the ALTERNATE FURNACE INTERLOCK WIRING.

## OPERATING THE HRV WITH THE EVOLUTION AND INFINITY CONTROL

The ventilator has four settings in heating mode and three settings in cooling mode.

### Heating:

**AUTO** - the ventilator selects the speed based on indoor humidity and outdoor temperature. It may cycle on/off every 30 minutes depending on humidity and outside temperature.

**LOW** - low speed all of the time.

**HIGH** - high speed all of the time.

**DEHUM** - will only turn on if humidity is 3% over setpoint. The speed is determined by indoor humidity and outdoor temperature.

### Cooling:

**AUTO** - the ventilator selects the speed based on indoor humidity and outdoor temperature. It may cycle on/off every 30 minutes depending on humidity and outside temperature.

**LOW** - low speed all of the time.

**HIGH** - high speed all of the time.

If the fan speed is set to Auto and the ventilator wants to run, the fan speed will run at High continuous speed. Otherwise, the fan will stay at the chosen continuous fan speed.

### Wiring

Remove top cover assembly from wall control and pass thermostat wire through hole located on back of control before attaching to wall. Connect Y, R, G, and B (yellow, red, green and black) between wall control and HRV circuit board. Following color code (see Fig. 28 and Fig. 29). Replace top cover assembly.

**NOTE:** HRV wall control and circuit board operate on 12vdc.

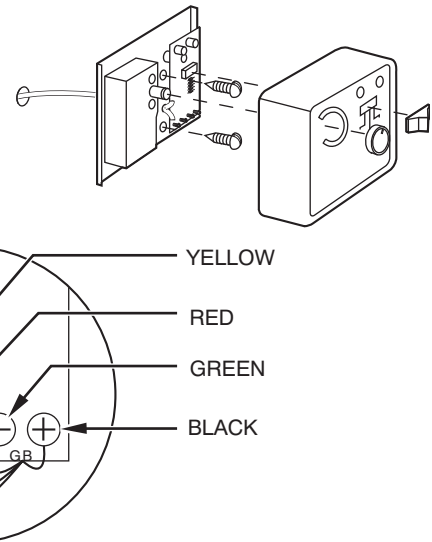

Fig. 28 - Typical Wall Control

A98383

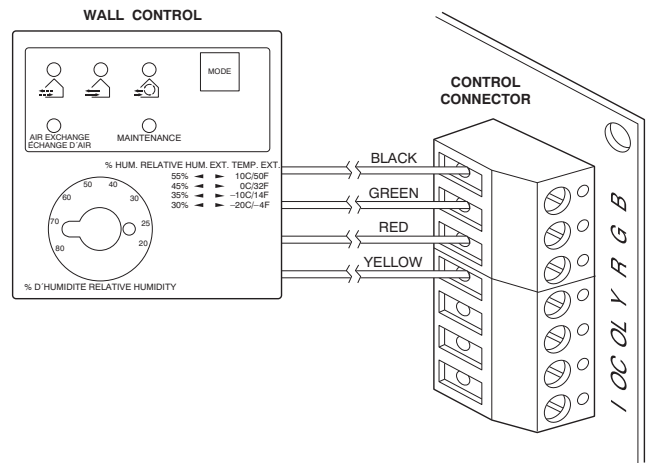

Fig. 29 - Control Connections

A98410

## Defrost Cycles Tables

Table 5 – HRVXXLHB1150

OUTSIDE TEMPERATURE		DEFROST CYCLES (MINUTES)		EXTENDED DEFROST CYCLES	
Celsius (°C)	Fahrenheit (°F)	Defrosting	Operation Time Between Each Defrost Cycles	Defrosting	Operation Time Between Each Defrost Cycles
- 5	23	7	50	10	30
- 15	5	7	25	10	20
- 27	- 17	10	20	10	15

Table 6 – HRVXXLHB1250

OUTSIDE TEMPERATURE		DEFROST CYCLES (MINUTES)		EXTENDED DEFROST CYCLES	
Celsius (°C)	Fahrenheit (°F)	Defrosting	Operation Time Between Each Defrost Cycles	Defrosting	Operation Time Between Each Defrost Cycles
- 5	23	6	50	10	30
- 15	5	6	25	10	20
- 27	- 17	10	20	10	15

## AIRFLOW BALANCING

### What You Need to Balance the Unit

- A magnehelic gauge capable of measuring 0 to 0.5 inch of water (0 to 125 Pa) and 2 plastic tubes.
- The balancing chart of the unit.

### Preliminary Stage to Balance the Unit

- Seal all the unit ductwork with tape. Close all windows and doors.
- Turn off all exhaust devices such as range hood, dryer and bathroom fans.
- Make sure the integrated balancing dampers are fully open.
- Make sure all filters are clean (if it is not the first time the unit is balanced).

### Balancing Procedure

1. Set the unit to high speed.  
Make sure that the furnace/air handler blower is ON if the installation is in any way connected to the ductwork of the cold air return. If not, leave furnace/air handler blower OFF. If the outside temperature is below 0°C/32°F, make sure the unit is not running in defrost while balancing. (By waiting 10 minutes after plugging the unit in, you are assured that the unit is not in a defrost cycle.)
2. Place the magnehelic gauge on a level surface and adjust it to zero.

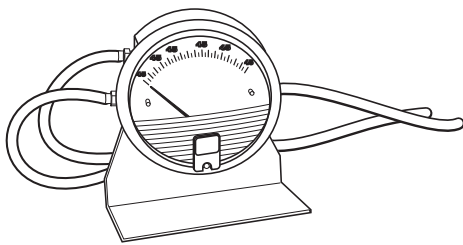

Fig. 30 - Magnehelic Gauge

A11217

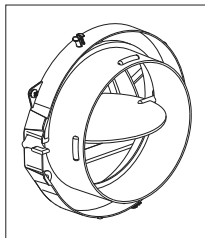

Fig. 31 - Open Balancing Damper

A12307

3. Connect tubing from gauge to EXHAUST air flow pressure taps (see diagram at right). Be sure to connect the tubes to their appropriate high/low fittings. If the gauge drops below zero, reverse the tubing connections.

**NOTE:** It is suggested to start with the exhaust air flow reading because the exhaust has typically more restriction than the fresh air, especially in cases of fully ducted installations or source point ventilation.

Place the magnehelic gauge upright and level. Record equivalent AIR FLOW of the reading according to the balancing chart.

4. Move tubing to FRESH air flow pressure taps (see diagram). Adjust the fresh air balancing damper until the FRESH air flow is approximately the same as the EXHAUST air flow. If FRESH air flow is less than EXHAUST air flow, then go back and adjust the exhaust balancing damper to equal the FRESH air flow.
5. Secure both dampers in place with a fastening screw.
6. Write the required air flow information on a label and stick it near the unit for future reference (date, maximum speed air flows, your name, phone number and business address).
7. Install 4 pressure taps plugs (included in parts bag).

### NOTES:

1. Use conversion chart provided with the unit to convert magnehelic gauge readings to equivalent cfm values.
2. The unit is considered balanced even if there is a difference of ±10 cfm (or ±5 l/s or 17 m<sup>3</sup>/h) between the two air flows.

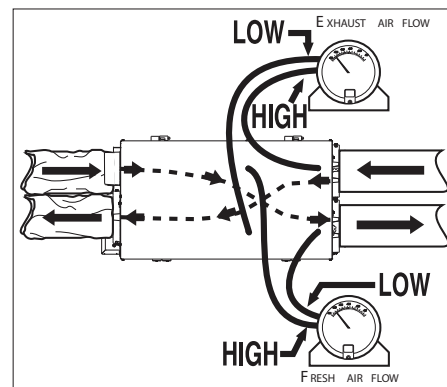

Fig. 32 - Balancing Procedure

A12305

**WIRING DIAGRAM**

**Critical characteristic.**

- NOTES**
1. For continued fire protection. Use specified UL listed/CSA Certified line fuse.
  2. If any of the original wire, as supplied, must be replaced, use the same equivalent wire.
  3. Field wiring must comply with applicable codes, ordinances and regulations.
  4. Remote controls (class 2 circuit) available, see instruction manual.
  5. Furnace fan circuit must be class 2 circuit only.

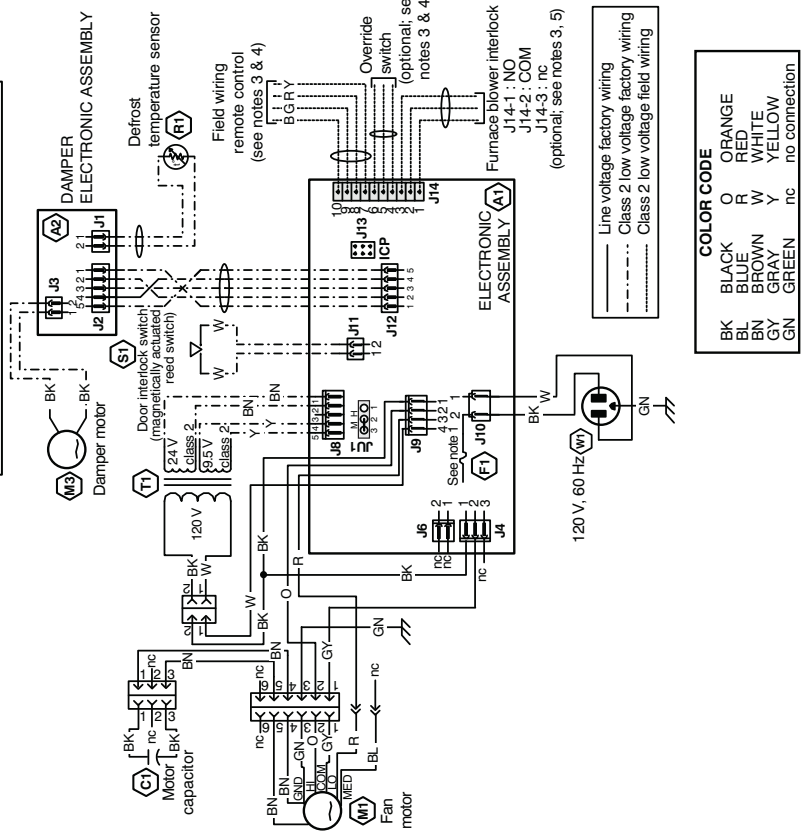

**COLOR CODE**

BK	BLACK	O	ORANGE
BL	BLUE	R	RED
BRN	BROWN	W	WHITE
GY	GRAY	Y	YELLOW
GN	GREEN	nc	nc connection

- Line voltage factory wiring
- Class 2 low voltage factory wiring
- Class 2 low voltage field wiring

**LOGIC DIAGRAM**

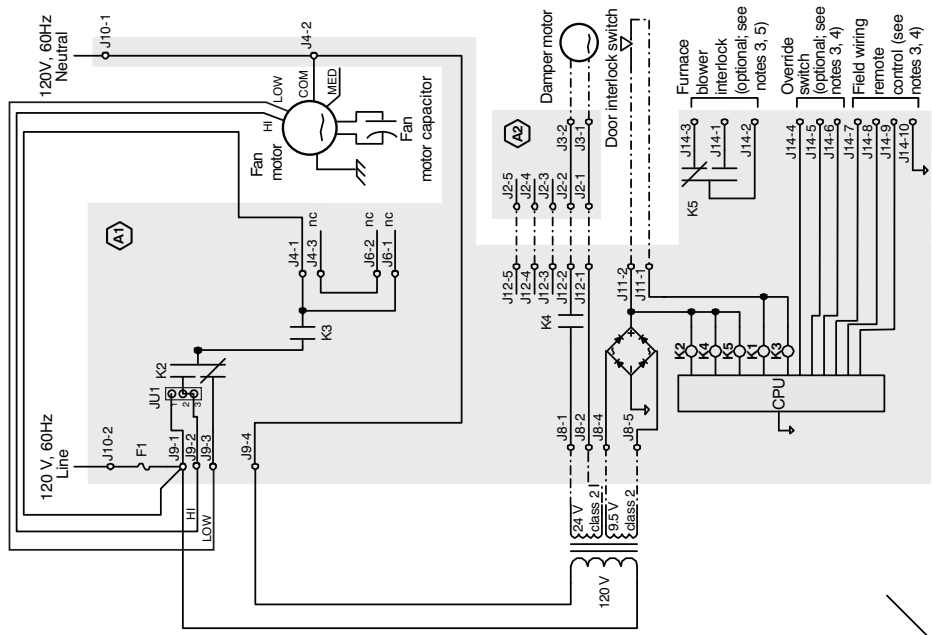

**Fig. 33 - Wiring Diagram**

## CARE AND MAINTENANCE

### **WARNING**

#### **ELECTRICAL SHOCK HAZARD**

Failure to follow this warning could result in personal injury or death.

Before installing or servicing system, always turn off, tag and lockout main power to system. There may be more than 1 disconnect switch.

### **CAUTION**

#### **CUT HAZARD**

Failure to follow this caution may result in personal injury.

Sheet metal parts may have sharp edges or burrs. Use care and wear appropriate protective clothing and gloves when handling parts.

### **Door**

HRV door can be removed by unlatching brief case style latches, then slide door to the right and remove it from hinges. Door must be in place and secured shut for proper operation.

### **Filter**

Filters in HRV are washable and should be cleaned every 3 months. Use a vacuum cleaner to remove heaviest portion of accumulated dust, then wash in lukewarm water. Allow filter to completely dry before reinstalling. A dirty air filter will cause excessive strain on blower motor. Never operate unit without a filter. Vacuum out debris.

In addition, regularly check and clean screens on exterior intake and exhaust hoods when necessary.

### **CAUTION**

#### **UNIT COMPONENT DAMAGE HAZARD**

Failure to follow this caution may result in unit component damage.

DO NOT clean filters in a dishwasher and DO NOT dry them with a heating appliance or permanent damage will result.

### **Blower Motor and Wheel**

HRV blower motors are factory lubricated for life. Lubricating bearings is not recommended. However, inspect and clean any accumulated dirt and grease from blower motor and wheel annually.

### **Cleaning the Core**

HRV unit is equipped with special heat recovery core and must be handled with care. We recommend that it be washed once a year following the season of most intense use. This will ensure maximum efficiency of the plastic partitions within the core.

Allow heat recovery core to soak for 3 hours in a solution of warm water and mild soap. Rinse under stream of water. Hot water and strong detergent will damage core and should NOT be used.

## TROUBLESHOOTING

### **WARNING**

#### **ELECTRICAL SHOCK HAZARD**

Failure to follow this warning could result in personal injury or death.

Before installing or servicing system, always turn off, tag and lockout main power to system. There may be more than 1 disconnect switch.

### **CAUTION**

#### **CUT HAZARD**

Failure to follow this caution may result in personal injury.

Sheet metal parts may have sharp edges or burrs. Use care and wear appropriate protective clothing and gloves when handling parts.

**NOTE:** Reference Table 7 Troubleshooting Chart

This can be a quick guide in resolving unit problems. It is also recommended to review and understand Wall Control Board Operation and Care and Maintenance sections before continuing. There are 3 main parts to focus on when troubleshooting HRV unit: **wall control, electronic control board and blower motor.**

#### **Wall Control**

Typically, the wall control is either good or it is bad. Use Table 1, 2, or 4 to determine if wall control is operating correctly. Use Fig. 28 to check control wire connections.

**NOTE:** The electronic control board and wall control operate on 12vdc.

#### **Control Board**

In addition, outside air thermistor must be connected to control board for it to operate properly. See Table 9, Temperature/Ohm Relationship, for valid temperature range.

#### **Blower Motor**

The HRV blower motor operates on 115VAC, with 2-speed operation.

The easiest way to check blower speed operation is to use the integrated control and initiate a low-speed blower (amber LED) and high-speed blower operation (green LED).

**NOTE:** If there is a short circuit or an open circuit at thermistor, CPU will go into a 10 minute defrost cycle every 20 minutes.

**Table 7 – Troubleshooting**

If the integrated control LED of the unit is flashing, this means the unit sensors detected a problem. See the list below to know where on the unit the problem occurs.

- LED flashes GREEN (double blink). • Thermistor error. Replace the thermistor kit
- LED flashes AMBER. • Damper error. Go to Problem 6 below.

**IMPORTANT:** A few diagnosis procedures may require the unit to be in operation while proceeding. Open the unit door and bypass its magnetic switch by putting the door white magnet on it. Be careful with moving and/or live parts.

PROBLEMS	POSSIBLE CAUSES	YOU SHOULD TRY THIS
1. Unit does not work (no LED is lit on the integrated control).	<ul style="list-style-type: none"> <li>• The transformer may be defective.</li> <li>• The circuit board may be defective.</li> </ul>	<ul style="list-style-type: none"> <li>• Check for 24 VAC on J8-1 and J8-2.</li> <li>• Unplug the unit. Disconnect the main control and the optional control(s) (if need be). Jump G and B terminals. Plug the unit back and wait about 10 seconds. If the motors run on high speed and the damper opens, the circuit board is not defective.</li> </ul>
2. The damper actuator does not work or rotates continuously.	<ul style="list-style-type: none"> <li>• The unit is unplugged.</li> <li>• The unit door is opened.</li> <li>• A fuse is blown.</li> <li>• Wrong control connections.</li> </ul>	<ul style="list-style-type: none"> <li>• Plug the unit.</li> <li>• Close unit door</li> <li>• Inspect fuse on circuit board.</li> <li>• Try the integrated control.</li> </ul>
3. The wall control does not work OR its indicator flashes.	<ul style="list-style-type: none"> <li>• The damper actuator or the integrated damper port mechanism may be defective (integrated control LED flashes AMBER and unit is OFF).</li> <li>• The circuit board or the transformer may be defective(integrated control LED flashes AMBER and unit is OFF) .</li> </ul>	<ul style="list-style-type: none"> <li>• Unplug the unit. Disconnect the main control and the optional controls(s) (if need be).Wait 10 seconds and plug the unit back. Check if the damper opens. If not, use a multimeter and check for 24VAC on J12-1 and J12-2 (in electrical compartment). If there is 24VAC, replace the entire port assembly. <b>NOTE:</b> It is normal to experience a small delay (7-8 seconds) before detecting the 24VAC signal at starting-up. This signal will stay during 17-18 seconds before disappearing.</li> <li>• If there is no 24VAC, check for 24VAC between J8-1 and J8-2. If there is 24VAC, replace the circuit board, and if there is no 24VAC, change the transformer.</li> </ul>
4. The dehumidistat does not work OR the push button timer does not work OR its indicator light does not stay on.	<ul style="list-style-type: none"> <li>• The wires may be in reverse position.</li> <li>• The wires may be broken.</li> <li>• The wire in the wall OR the wall.</li> </ul>	<ul style="list-style-type: none"> <li>• Ensure that the color coded wires have been connected to their work OR its indicator flashes. appropriate places.</li> <li>• Inspect every wire and replace any that are damaged.</li> <li>• Remove the wall control and test it right beside the unit using another control may be defective. shorter wire. If the wall control works there, change the wire. If it does not, change the wall control.</li> </ul>
5. The motor does not work.	<ul style="list-style-type: none"> <li>• The wires may be in reverse position.</li> <li>• The dehumidified or push button may be defective.</li> </ul>	<ul style="list-style-type: none"> <li>• Ensure that the color coded wires have been connected to their appropriate places.</li> <li>• Jump the OL and OC terminals. If the unit switches to high speed, remove the dehumidistat or push button and test it right beside the unit using another shorter wire. If it works here, change the wire. If it doesn't, change the dehumidistat or the push button.</li> </ul>
	<ul style="list-style-type: none"> <li>• The circuit board may be defective.</li> <li>• The motor may be defective.</li> <li>• The motor capacitor may be defective.</li> <li>• The motor is unplugged from inside the unit.</li> <li>• The motor is unplugged from the electronic board (J4).</li> <li>• There is a problem with the door magnet switch.</li> <li>• JU-1 jumper is missing or in wrong position</li> </ul>	<ul style="list-style-type: none"> <li>• Press on the integrated control push button until the unit turns on low speed (the LED will light AMBER). Using a multimeter, check the voltage on J9-4 and J9-3. Refer to Wiring Diagram. The reading must be 120 VAC. Then set the unit on high speed by pressing on the integrated control push button one more time (the LED will light GREEN). Using a multimeter, check the voltage on J9-4 and J9-2. The reading must be 120 VAC Check also between J4-2 and J4-1, the reading must be 120 VAC Refer to Wiring Diagram. Check if the fuse F1 is intact. If all the readings correspond to the right voltage values, the circuit board is not defective. If one or both readings are different, change the circuit board.</li> <li>• Using a multimeter, check for 120VAC for the following speeds: High Speed: between GREY and ORANGE wires; Low/Medium Speed: between GREY and RED/BLUE wires. Refer to the Wiring Diagram.</li> <li>• Unplug the unit. Check for continuity between Pin 5 on the 6-pin connector (brown leads) and Pin 3 of the capacitor connector. Also check for continuity between Pin 4 on the 6-pin connector (brown leads) and Pin 1 of the capacitor connector. Refer to Wiring Diagram.</li> <li>• Open the door and ensure that the wire going to the motor is connected.</li> <li>• Check J4 motor connection on circuit board.</li> <li>• Door magnet switch is missing or not in its place.</li> <li>• Ensure JU-1 jumper is set on "M" speed.</li> </ul>

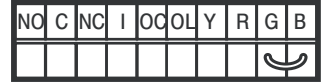

PROBLEMS	POSSIBLE CAUSES	YOU SHOULD TRY THIS
6. The defrost cycle does not work (the fresh air duct is frozen OR the fresh air distributed is very cold).	<ul style="list-style-type: none"> <li>Ice deposits may be hindering the damper operation.</li> <li>The damper rod or the port damper itself may be broken.</li> <li>The damper actuator or circuit board may be defective.</li> </ul>	<ul style="list-style-type: none"> <li>Remove the ice.</li> <li>Inspect these parts and replace if necessary.</li> <li>See Problem 2.</li> </ul>
7. The integrated control push button does not work.	<ul style="list-style-type: none"> <li>The 30-second boot sequence is not completed.</li> <li>The circuit board may be defective.</li> <li>The transformer may be defective</li> </ul>	<ul style="list-style-type: none"> <li>See Boot Sequence.</li> <li>Check voltage going to circuit board J8-1 and J8-2.</li> <li>Check for 24 VAC on J8-1 and J8-2.</li> </ul>

To prevent interior condensation on windows, do not exceed the humidity levels shown in Table 8.

**Table 8 – Recommended Humidity Levels**

OUTSIDE TEMPERATURE	DOUBLE- PANE WINDOWS	TRIPLE- PANE WINDOWS
50°F / 10°C	55%	65%
32°F / 0°C	45%	55%
14°F / - 10°C	35%	45%
- 4°F / - 20°C	30%	45%
- 22°F / - 30°C	25%	35%

**Table 9 – Temperature/Ohm Relationship**

TEMP. (°F/ 5C)	(k Ohms)	TEMP. (°F/ 5C)	(k Ohms)	TEMP. (°F/ 5C)	(k Ohms)	TEMP. (°F/ 5C)	(k Ohms)	TEMP. (°F/ 5C)	(k Ohms)
- 58/- 50	329.5	0/- 18	61.54	55/13	15.90	112/44	5.080	167/75	1.924
- 56/- 49	310.9	1/- 17	58.68	57/14	15.28	113/45	4.911	169/76	1.869
- 54/- 48	293.5	3/- 16	55.97	59/15	14.69	114/46	4.749	171/77	1.816
- 52/- 47	277.2	5/- 15	53.41	61/16	14.12	116/47	4.593	172/78	1.765
- 51/- 46	262.0	7/- 14	50.98	63/17	13.58	118/48	4.443	174/79	1.716
- 49/- 45	247.7	9/- 13	48.68	64/18	13.06	120/49	4.299	176/80	1.668
- 47/- 44	234.3	10/- 12	46.50	66/19	12.56	122/50	4.160	178/81	1.622
- 45/- 43	221.7	12/- 11	44.43	68/20	12.09	124/51	4.026	180/82	1.577
- 44/- 42	209.9	14/- 10	42.47	70/21	11.63	126/52	3.896	181/83	1.533
- 43/- 41	198.9	16/- 9	40.57	72/22	11.20	128/53	3.771	183/84	1.492
- 40/- 40	188.5	18/- 8	38.77	73/23	10.78	129/54	3.651	185/85	1.451
- 38/- 39	178.5	19/- 7	37.06	75/24	10.38	131/55	3.536	187/86	1.412
- 36/- 38	169.0	21/- 6	35.44	77/25	10.00	133/56	3.425	189/87	1.373
- 34/- 37	160.2	23/- 5	33.90	79/26	9.632	135/57	3.318	191/88	1.336
- 32/- 36	151.9	25/- 4	32.44	81/27	9.281	137/58	3.215	192/89	1.301
- 30/- 35	144.1	27/- 3	31.05	82/28	8.944	138/59	3.116	194/90	1.266
- 28/- 34	136.7	28/- 2	29.73	84/29	8.622	140/60	3.020	196/91	1.232
- 27/- 33	129.8	30/- 1	28.48	86/30	8.313	142/61	2.927	198/92	1.200
- 26/- 32	123.3	32/0	27.28	88/31	8.014	144/62	2.838	199/93	1.168
- 24/- 31	117.1	34/1	26.13	90/32	7.728	145/63	2.751	201/94	1.137
- 22/- 30	111.3	36/2	25.03	92/33	7.454	147/64	2.668	203/95	1.108
- 20/- 29	105.7	37/3	23.99	94/34	7.192	149/65	2.588	205/96	1.079
- 18/- 28	100.5	39/4	23.00	96/35	6.940	151/66	2.511	207/97	1.051
- 16/- 27	95.52	41/5	22.05	98/36	6.699	153/67	2.436	208/98	1.024
- 14/- 26	90.84	43/6	21.15	99/37	6.467	155/68	2.364	210/99	0.9984
- 12/- 25	86.43	45/7	20.30	100/38	6.245	156/69	2.295	212/100	0.9731
- 10/- 24	82.26	46/8	19.48	102/39	6.032	158/70	2.228	214/101	0.9484
- 9/- 23	78.33	48/9	18.70	104/40	5.827	160/71	2.163	216/102	0.9246
- 8/- 22	74.61	50/10	17.96	106/41	5.629	162/72	2.100	217/103	0.9014
- 6/- 21	71.10	52/11	17.24	108/42	5.438	164/73	2.039	219/104	0.8789
- 4/- 20	67.77	54/12	16.56	110/43	5.255	165/74	1.980	221/105	0.8572
- 2/- 19	64.57								