



Corp. 1243-L9
Revised September 1, 2014

INSTALLATION AND SERVICE PROCEDURES

MS8 SERIES



MS8 SERIES UNITS — MINI-SPLIT SINGLE-ZONE SYSTEMS (115V)



MS8-CO Air Conditioner Outdoor Unit
MS8-HO Heat Pump Outdoor Unit



MS8-CI Air Conditioner Indoor Unit
MS8-HI Heat Pump Indoor Unit



Wireless
Remote Control
(furnished)

TABLE OF CONTENTS

I. OVERVIEW

Shipping and Packing List	2
Required Tools and Supplies	3
Specifications	4
Model Number Identification	7
Unit Dimensions and Weights	7
Typical System Component Setup	7

II. INSTALLATION

General	9
Clearances	9
Torque Requirements for Caps and Fasteners	9
Setting Outdoor Unit	9
Repositioning Indoor Air Temperature Sensor	11
Indoor Unit Placement and Preparation	11
Indoor Unit Cable Connections	14
Securing Indoor Unit to Wall Mounting Bracket	15
Outdoor Unit Cable Connections	16
Operating Service Valves	17
Line Set Requirements	18
Leak Test and Evacuation	21
Unit Start-Up	21
Adding Refrigerant for Longer Line Sets	22
Checking Large Line Operating Pressures	22
Wrapping Bundle	23
Maintenance	24

III. OPERATING THE WIRELESS REMOTE

IV. SYSTEM OPERATION AND SERVICE

System Operational Modes	33
System Functions	41
System Protection Features	41
Temperature Sensors (Location, Function and Troubleshooting)	43
Optimal System Operating Ranges	49
Indoor and Outdoor Control Parts Identifications	51
Indoor and Outdoor Error Codes	53
Refrigerant System Flow Diagrams	61
Typical Unit Wiring Diagrams	62
Troubleshooting	65
Major System Components	74
Disassembly Procedures	81

V. ACCESSORIES AND PARTS

Product View and Part Replacement	91
---	----

CAUTION

Physical contact with metal edges and corners while applying excessive force or rapid motion can result in personal injury. Be aware of, and use caution when working near these areas during installation or while servicing this equipment.

WARNING

Improper installation, adjustment, alteration, service or maintenance can cause personal injury, loss of life, or damage to property.
Installation and service must be performed by a licensed professional installer (or equivalent) or a service agency.

IMPORTANT

The Clean Air Act of 1990 bans the intentional venting of refrigerant (CFCs, HCFCs and HFCs) as of July 1, 1992. Approved methods of recovery, recycling or reclaiming must be followed. Fines and/or incarceration may be levied for noncompliance.

IMPORTANT

These units must be installed as a matched system as specified in the Lennox Engineering Handbook.



I. OVERVIEW

Shipping and Packing List

Check the unit components for shipping damage. If you find any damage, immediately contact the last carrier.

1 — ASSEMBLED INDOOR UNIT

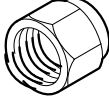
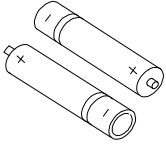
The assembled indoor unit will include the following items:

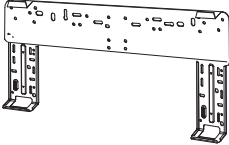
Part Picture	Part Name	Part Picture	Name Name
	Remote control (1 each)		1/4" flare nut (45°-degree SAE style) for small line (1 each)
	Batteries (AAA) (2 each)		Foam tube insulation (for condensate line attached to indoor unit)
	Wall mounting bracket screws (5 each)		
	Wall mounting bracket (1 each)		





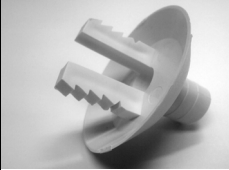

1 — ASSEMBLED OUTDOOR UNIT

The assembled outdoor unit will include the following items which are located with the unit:

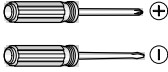
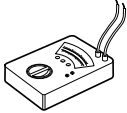
Parts	Figure	Quantity	Parts	Figure	Quantity
Auxiliary drain hole plugs (heat pump only)		1 - 3	Drain plug (heat pump only)		1

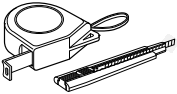
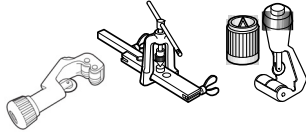
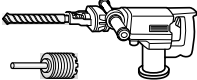
Required Tools and Supplies

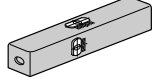
INSTALLATION TOOLS

Tool Picture	Tool Name	Tool Picture	Tool Name
	Screw driver		Multimeter
	Electric drill		Allen wrench set (metric)
	Measuring tape and knife		Flaring tool and pipe cutter
	Hole core drill		Refrigerant leak detector or a bottle of soapy water
	Adjustable wrench		Level
	A 5/16" female flare to 1/4" male flare adapter (order Lennox catalog number Y0576)		Micron gauge

SUPPLIES

The following field-provided supplies may be required for installation

- * Line set (see table 7 for requirements)
- * Foam insulation (line set and condensate line)
- * UV rated protective tape (used to maintain positioning of bundle). Bundle consists of line set, condensate line and wiring between indoor and outdoor units.
- * UV rated cable ties
- * Outdoor unit pad
- * Outdoor disconnect switch (indoor unit disconnect switch may be required by local code)
- * Cable (4-conductor). All need to be rated either 115V and sized per NEC).

NOTE — Stranded wire must be used to connect the outdoor unit to the indoor unit. The stranded wire is necessary to ensure proper system communication and operation.

- * Plastic wall screw anchors
- * Exterior wall channel (optional)
- * Wall sleeve or PVC tubing material to field fabricate a wall sleeve for line set, condensate line and wiring (utility bundle).

Specifications - AIR CONDITIONER SYSTEMS
OUTDOOR UNIT

Nominal Tonnage		0.75	1
Outdoor Unit Model No.		MS8-CO-09L	MS8-CO-12L
Connections (in.)	Small line o.d. - flare	1/4	1/4
	Large line o.d. - flare	3/8	3/8
Ambient Temperature Operating Range - °F		41 - 115	41 - 115
¹ Refrigerant (R-410A) furnished		2 lbs. 6 oz.	2 lbs. 14 oz.
Outdoor Coil	Net face area - sq. ft.	3.95	4.08
	Tube diameter - in.	1/4	3/8
	Number of rows	2	2
	Fins per inch	18	18
Outdoor Fan Motor	Diameter - in.	15-5/8	15-5/8
	No. of blades	3	3
	Cfm	1120	1120
	Rpm	650/900	680/900
Shipping Data - lbs.	Outdoor Unit	91	97

ELECTRICAL DATA

Line voltage data - 60 hz - 1ph		115V	115V
² Maximum over-current protection (amps)		35	40
³ Minimum circuit ampacity		22	23
Compressor	Rated load amps	16	17.5
⁴ Compressor Power Input (W)		1050	1450
Outdoor Fan Motor	Rated load amps	0.17	0.17
	Output (W)	40	40

MATCHING INDOOR UNIT

Indoor Unit Model No.		MS8-CI-09L	MS8-CI-12L
Connections (in.)	Small line o.d. - flare	1/4	1/4
	Large line o.d. - flare	3/8	3/8
Indoor Blower Air Volume (cfm)	Turbo	330	300
	High	295	275
	Medium	255	255
	Low	220	215
Indoor Blower RPM	Turbo	1260	1260
	High	1050	1070
	Medium	920	900
	Low	730	730
Indoor Coil	Net face area - sq. ft.	1.85	1.85
	Tube diameter - in.	1/4	1/4
	Number of rows	2	2
	Fins per inch	18	18
Indoor Blower	Diameter x Length - in.	3.6 x 25.4	3.6 x 25.4
	Type	Cross-flow	Cross-flow
Shipping Data - lbs.	Indoor Unit	31	31

ELECTRICAL DATA

Line voltage data - 60 hz - 1ph		115V	115V
	Rated Load Amps	0.38	0.38
	Output (W)	20	20

NOTE - Extremes of operating range are plus 10% and minus 5% of line voltage.

¹ Refrigerant charge sufficient for 15 ft. of line set.

² HACR type circuit breaker or fuse.

³ Refer to National or Canadian Electrical Code manual to determine wire, fuse and disconnect size requirements.

⁴ Rated Input

Specifications - HEAT PUMP SYSTEMS

INDOOR UNIT			
Nominal Tonnage		0.75	1
Outdoor Unit Model No.		MS8-HO-09L	MS8-HO-12L
Connections (in.)	Small line o.d. - flare	1/4	1/4
	Large line o.d. - flare	3/8	3/8
Ambient Temperature Operating Range - °F		Cooling	41 - 115
		Heating	5 - 86
¹ Refrigerant (R-410A) furnished		2 lbs. 6 oz.	2 lbs. 14 oz.
Outdoor Coil	Net face area - sq. ft.	3.95	4.08
	Tube diameter - in.	1/4	3/8
	Number of rows	2	2
	Fins per inch	18	18
Outdoor Fan Motor	Diameter - in.	15-5/8	15-5/8
	No. of blades	3	3
	Cfm	1120	1120
	Rpm	650/900	680/900
Shipping Data - lbs.		Outdoor Unit	110 119
ELECTRICAL DATA			
Line voltage data - 60 hz - 1ph		115V	115V
² Max. Over-current protection (amps)		35	40
³ Minimum circuit ampacity		22	23
Compressor	Rated load amps	16	17.5
⁴ Compressor Power Input (W)		600	1200
Outdoor Fan Motor	Rated load amps	0.17	0.17
	Output (W)	40	40
MATCHING INDOOR UNIT			
Indoor Unit Model No.		MS8-HI-09L	MS8-HI-12L
Connections (in.)	Small line o.d. - flare	1/4	1/4
	Large line o.d. - flare	3/8	3/8
Indoor Blower Air Volume (cfm)	Turbo	330	300
	High	295	275
	Medium	255	255
	Low	220	215
Indoor Blower RPM (Cooling/Heating)	Turbo	1260/1320	1260/1280
	High	1050/1200	1070/1050
	Medium	920/1100	900/980
	Low	730/950	730/920
Indoor Coil	Net face area - sq. ft.	1.85	1.85
	Tube diameter - in.	1/4	1/4
	Number of rows	2	2
	Fins per inch	18	18
Indoor Blower	Diameter x Length - in.	3.6 x 25.4	3.6 x 25.4
	Type	Cross-flow	Cross-flow
Shipping Data - lbs.		Indoor Unit	37 37
ELECTRICAL DATA			
Line voltage data - 60 hz - 1ph		115V	115V
Rated Load Amps		0.38	0.38
Output (W)		20	20
NOTE - Extremes of operating range are plus 10% and minus 5% of line voltage. ¹ Refrigerant charge sufficient for 15 ft. of line set. ² HACR type circuit breaker or fuse. ³ Refer to National or Canadian Electrical Code manual to determine wire, fuse and disconnect size requirements. ⁴ Rated Input			

Model Number Identification

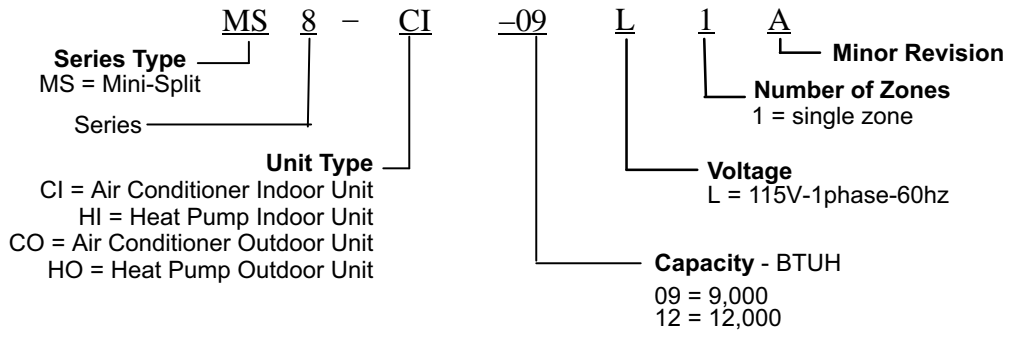

Model Number Identification

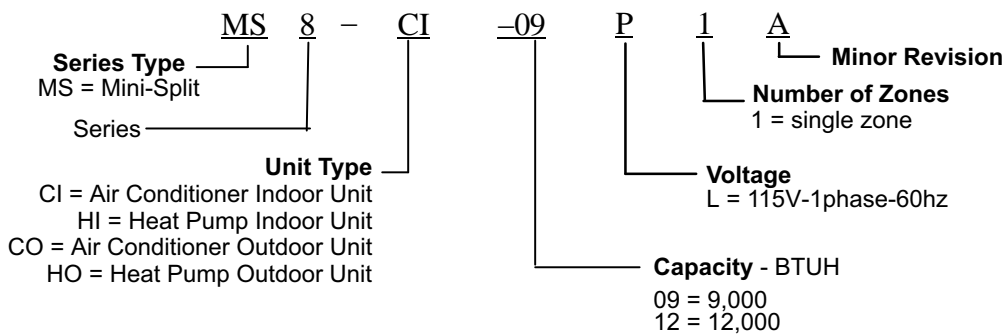

Unit Dimensions - inches (mm) and Weights

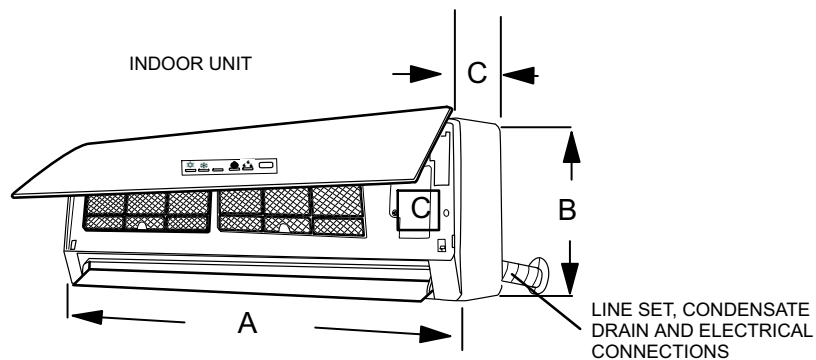

TABLE 1. INDOOR UNIT DIMENSIONS — INCHES

Model Size	A	B	C
-09 and -12	33-3/8	10-7/8	7

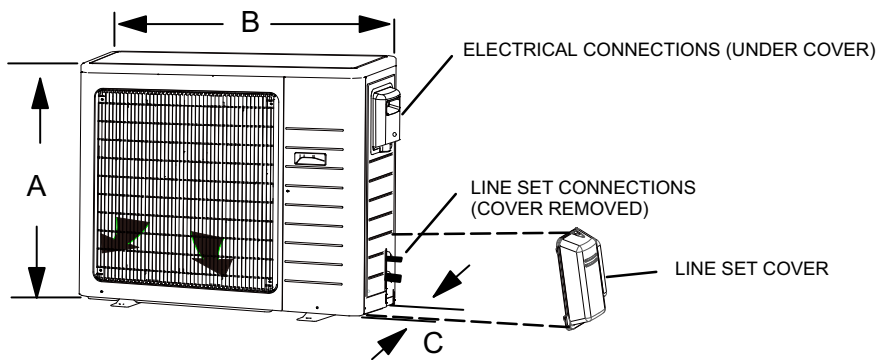

TABLE 2. OUTDOOR UNIT DIMENSIONS — INCHES

Model Size	A	B	C
-09 and -012	21-1/4	30	12-5/8

Typical System Component Setup

TYPICAL COMPONENT SETUP

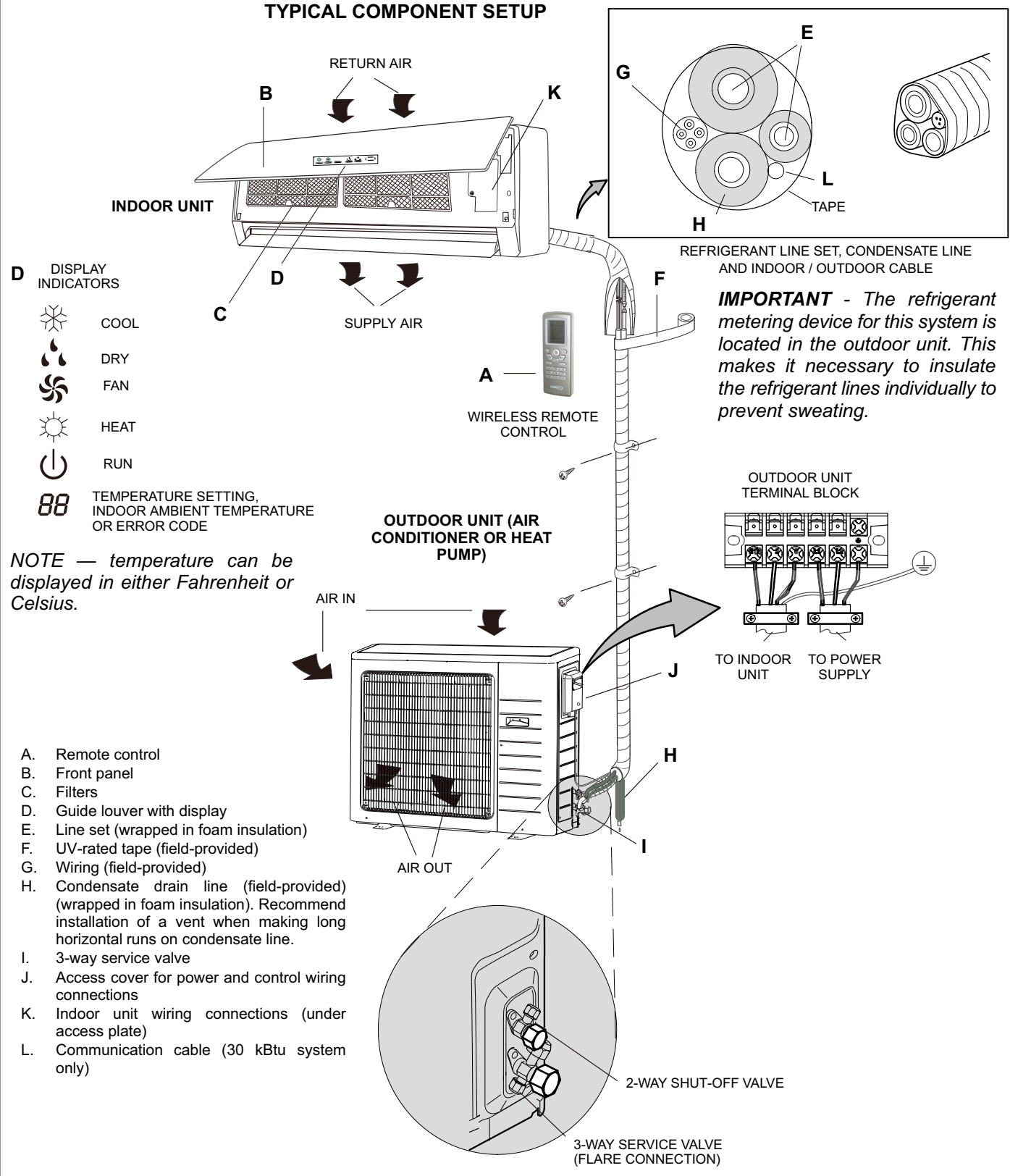

FIGURE 1

II. INSTALLATION

IMPORTANT INSTALLER INFORMATION

- * Confirm proper slope and routing of condensate lines to ensure moisture is drained away from the indoor unit (see procedure starting on page)
- * Confirm proper insulating, taping and bundling of refrigeration lines, main power lines and drain line (see procedure starting on pages 23).

General

The MS8 air conditioners and heat pumps are matched with an indoor evaporator unit to create a ductless system that uses HFC-410A refrigerant.

Clearances

⚠ CAUTION

In order to avoid injury, take proper precaution when lifting heavy objects.

SYSTEM CLEARANCES

Refer to figure 2 for mandatory installation clearance requirements.

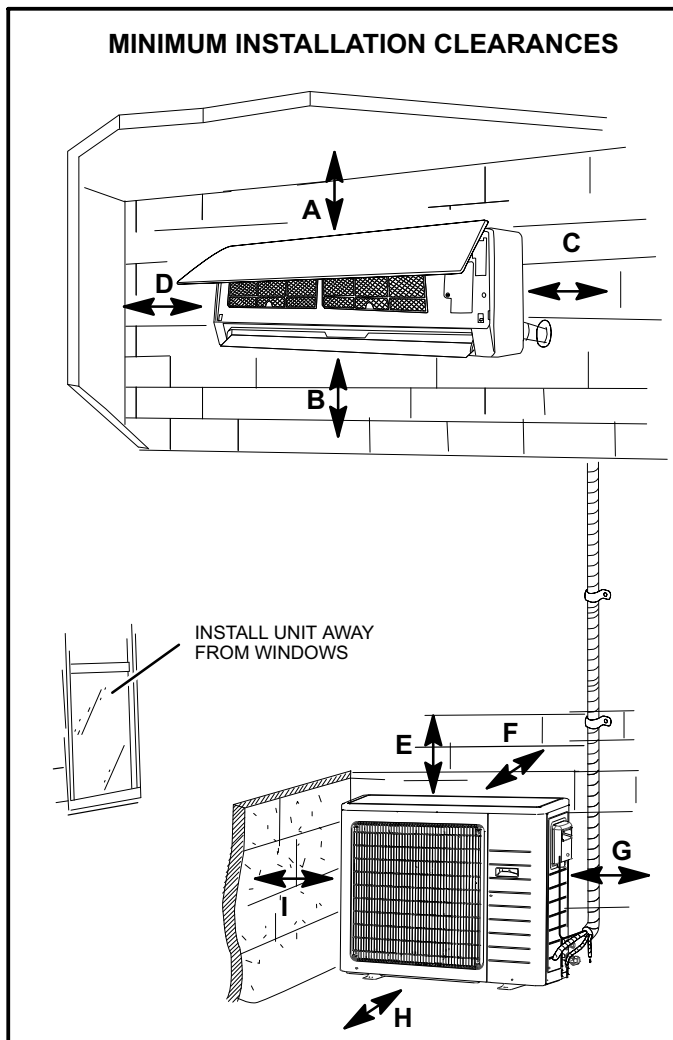

FIGURE 2

TABLE 3
MINIMUM SYSTEM CLEARANCES

ID	Location	Clearance Required
A	Clearance between unit and ceiling.	6 in. (152 mm)
B	Clearance between unit and floor.	6 ft.(1829 mm)
C / D	Clearance to the right and left of unit.	6 in. (152 mm)
E	Clearance above unit.	2 ft. (610 mm)
F	Clearance between air inlet and structure.	12 in. (305 mm)
G	Clearance between unit and structures	12 in. (305 mm)
H		4 ft. (1219 mm)
I		12 in. (305 mm)

Torque Requirements for Caps and Fasteners

When servicing or repairing HVAC components, ensure the fasteners are appropriately tightened. Table 4 provides torque values for fasteners.

⚠ IMPORTANT

Only use Allen wrenches of sufficient hardness (50Rc - Rockwell Harness Scale minimum). Fully insert the wrench into the valve stem recess.

Service valve stems are factory-torqued (from 9 ft-lbs for small valves, to 25 ft-lbs for large valves) to prevent refrigerant loss during shipping and handling. Using an Allen wrench rated at less than 50Rc risks rounding or breaking off the wrench, or stripping the valve stem recess.

See the Lennox Service and Application Notes #C-08-1 for further details and information.

TABLE 4
TORQUE REQUIREMENTS

Parts	Recommended Torque	
	United States Customary System*	Metric (Newton Meter)
Service valve cap	8 ft.- lb.	11
Sheet metal screws	16 in.- lb.	2
Machine screws #10	27 in.- lb.	3
Compressor bolts	7 ft.- lb.	10
Gauge port seal cap	8 ft.- lb.	11

*The United States customary system (also called American system) is a system of measurement commonly used in the United States. This system is based on the British Imperial System.

Setting Outdoor Unit

OUTDOOR UNIT POSITIONING CONSIDERATIONS (AIR CONDITIONER OR HEAT PUMP)

Consider the following when positioning the unit:

- * Some localities are adopting sound ordinances based on the unit's sound level registered from the adjacent property, not from the property where the unit is installed. Install the unit as far as possible from the property line.
- * When possible, do not install the unit directly outside a window. Glass has a very high level of sound transmission. For proper placement of unit in relation to a window see the provided illustration in figure 2.
- * Install unit level or, if on a slope, maintain slope tolerance of 2 degrees [or 2 inches per 5 feet (50 mm per 1.5 m)] away from building structure.
- * Install the unit high enough above the ground or roof to allow adequate drainage of defrost water and prevent ice or snow build-up (required for heat pumps).
- * In heavy snow areas, do not locate the unit where drifting will occur. The unit base should be elevated above the depth of average snows.
- * When installed in areas where low ambient temperatures exist, locate unit so winter prevailing winds do not blow directly onto outdoor unit.
- * Locate unit away from overhanging roof lines which would allow water or ice to drop on, or in front of, coil or into unit.

CONDENSATE DRAINAGE REQUIREMENT (HEAT PUMP ONLY)

Condensate formed during the heating and defrost processes must be drained from heat pump units. Drain holes are provided in the base of the units to ensure proper drainage. Heat pumps must be raised when installed on a concrete pad or the ground to allow drainage to occur. If the heat pump unit is installed on a wall mounting bracket, insert the provided drain connector into one of the 1 inch (25mm) drain holes and attached a field-provided insulated drain hose to the connector. Use the provided rubber plugs to cover any unused drain holes (figure 3).

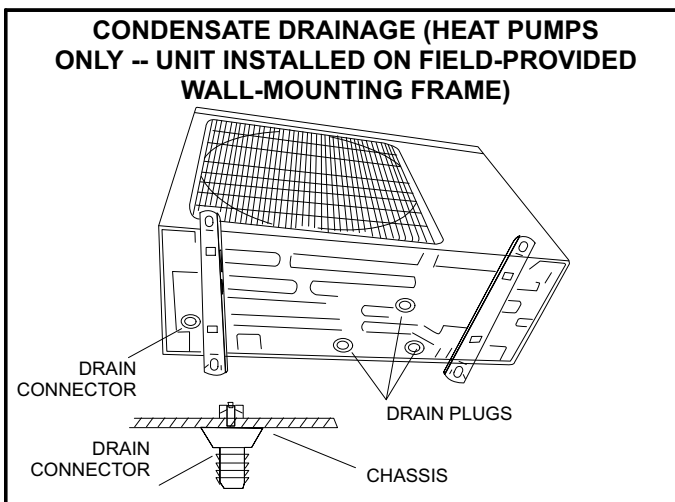

FIGURE 3

NOTICE

Roof Damage!

This system contains both refrigerant and oil. Some rubber roofing material may absorb oil. This will cause the rubber to swell when it comes into contact with oil. The rubber will then bubble and could cause leaks. Protect the roof surface to avoid exposure to refrigerant and oil during service and installation. Failure to follow this notice could result in damage to roof surface.

SLAB OR ROOF MOUNTING

Install the unit a minimum of 4 inches (102 mm) above the roof or ground surface to avoid ice build-up around the unit. Locate the unit above a load bearing wall or area of the roof that can adequately support the unit. Consult local codes for rooftop applications (figure 4).

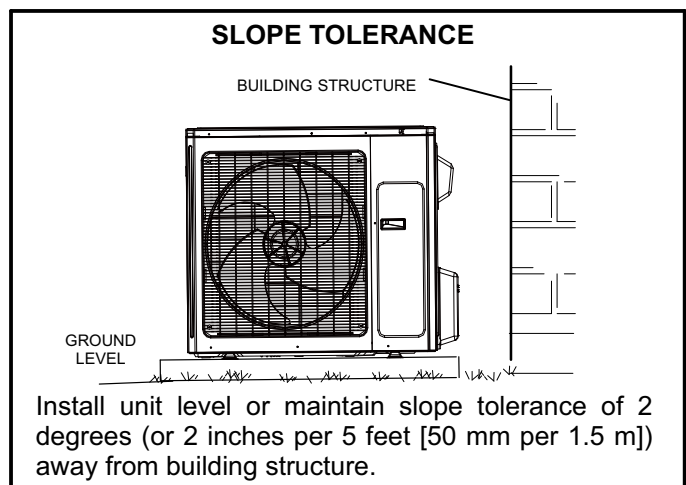

FIGURE 4

SECURING OUTDOOR UNIT TO SLAB OR FRAME

If the outdoor unit is installed on a field-provided slab or frame, use lag bolts or equivalent to secure the outdoor unit to the slab or frame (figure 5).

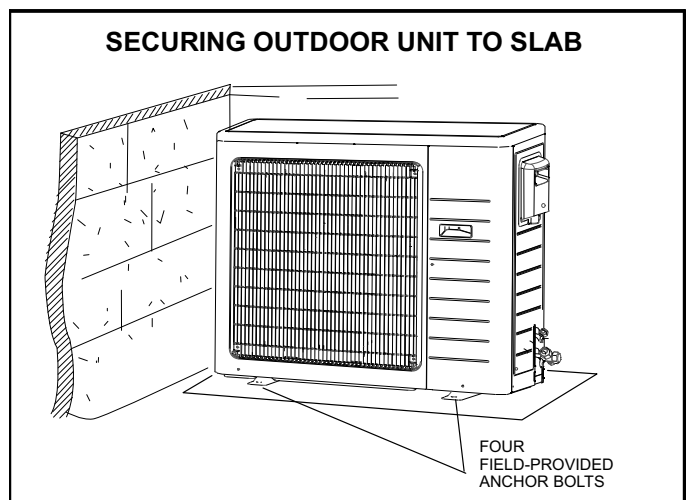

FIGURE 5

PREVAILING WINDS (HEAT PUMP ONLY)

If unit coil cannot be installed away from prevailing winter winds, a wind barrier should be constructed. Size barrier at least the same height and width as outdoor unit. Install barrier 12 inches minimum (305 mm) from the sides of the unit in the direction of prevailing winds as illustrated.

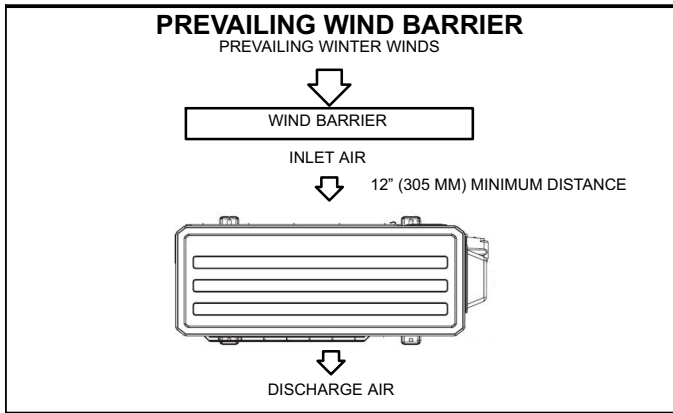

FIGURE 6

Repositioning Indoor Air Temperature Sensor

The indoor temperature sensor may be installed in an alternate location to facilitate shipping (figure 7). It is recommend that the sensor is relocated to the proper position shown in figure 8. Refer to the procedure on page 81 for removal of the front cover.

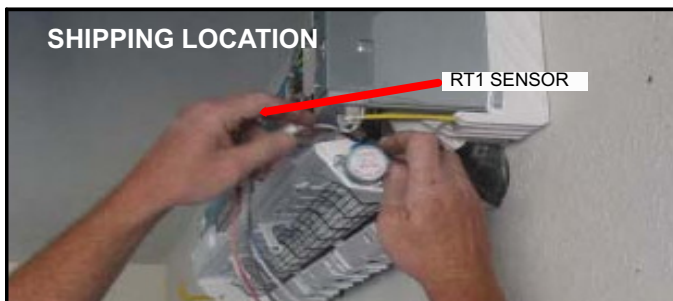

FIGURE 7

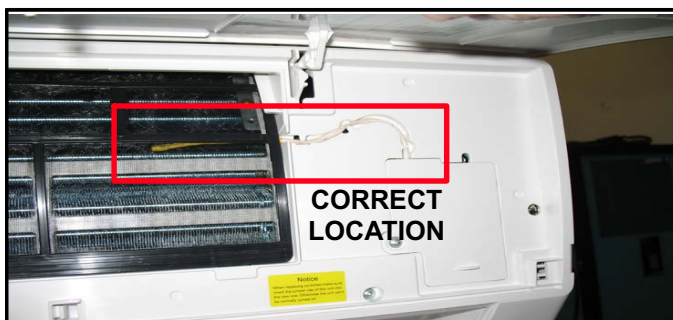

FIGURE 8

Indoor Unit Placement and Preparation

INDOOR UNIT LOCATION

Minimum clearances must be maintained as specified in figure 2. In addition, the following items should be considered:

AVOID

1. Direct sunlight if possible.
2. Locating unit less than 3-1/4" (1 meter) away from combustible materials and vapors.
3. Locating unit near heat sources which could affect system performance.

DO:

1. Locate the indoor unit where the room can be uniformly cooled. Install unit as high as possible on the wall for best performance.
2. Select a wall location that can support the weight of the unit.
3. Select a location where line set and condensate line will have the shortest run to the outside of the structure.
4. Allow sufficient space around unit for proper operation and maintenance.
5. Consider vertical rise between the indoor unit and outdoor unit. Do not exceed the maximum vertical line rise of the line set between the indoor unit and outdoor unit (table 9).
6. Install the indoor unit a minimum of 36 inches (914 mm) away from any antenna, power cords (lines), radio, telephone, security system, or intercom. Electrical noise and radio frequencies from any of these sources may affect operation.

DETERMINING WALL MOUNTING BRACKET LOCATION

1. Remove the wall mounting bracket from the indoor unit.
2. Determine the optimal exit location for bundle (line set, condensate line and wiring).

WALL MOUNTING BRACKET REMOVAL FROM INDOOR UNIT

- A. Remove the shipping screw that secures the wall mounting bracket to the rear of the unit.
- B. Remove bracket from rear panel of indoor unit.

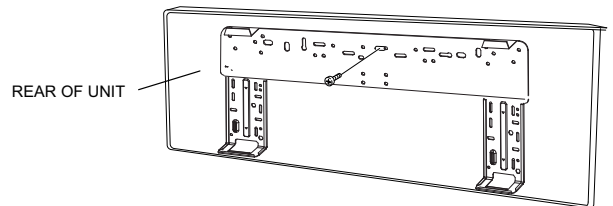

FIGURE 9

DETERMINING EXIT LOCATION

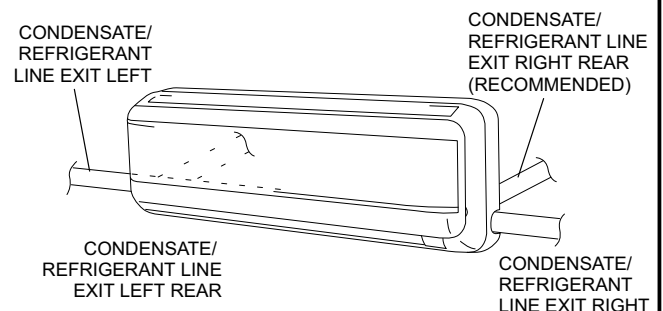

FIGURE 10

CONDENSATE / REFRIGERANT PIPING REAR EXIT LOCATIONS

09 – 12 kBtu

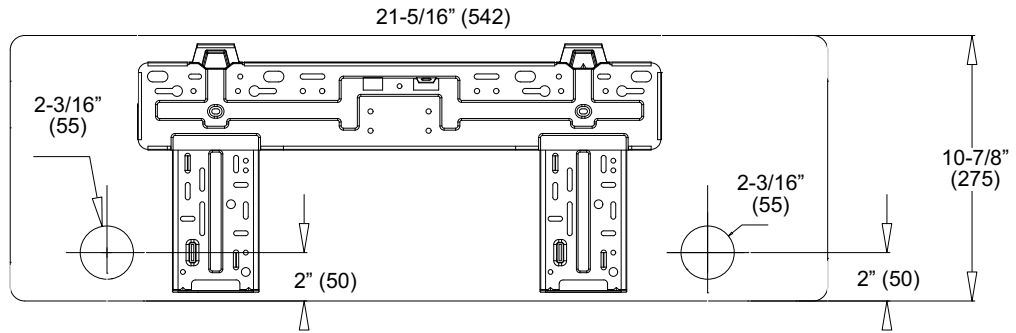

FIGURE 11

INSTALLING WALL SLEEVE

NOTE — If opposite-side exit is preferred, see figure 17 to switch condensate line and drain cap.

3. Use the wall mounting bracket as a template to determine the exit point for the line set, condensate line and indoor / outdoor cable (figure 11).
1. Prior to making the hole, check to ensure that neither studs nor plumbing are directly located behind the hole location.

⚠ CAUTION

Electric Shock Hazard. Can cause injury or death. Avoid location where electric wiring or conduits may be present inside the wall.

2. Use either a sabre saw, key hole saw or hole-cutting drill attachment to cut a 2-3/16-inch (55 mm) diameter hole in the wall. Hole should be at a slight downward slant - 3/16" to 3/8" (5 to 10 mm) to the outdoor side.

BORING HOLE FOR WALL SLEEVE

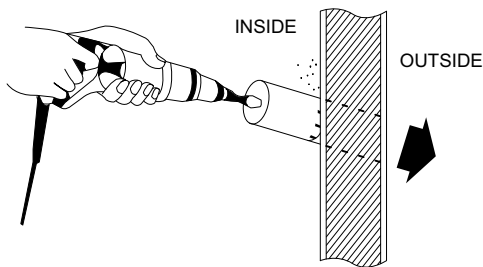
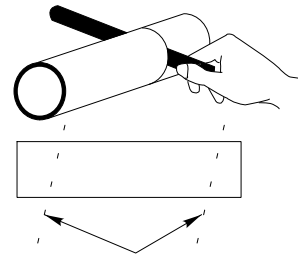

FIGURE 12

3. Measure the thickness of the wall from the inside edge to the outside edge and cut a field-provided PVC pipe at a slight angle 1/4" (6 mm) shorter than the thickness of the wall.

CUTTING PVC FOR WALL SLEEVE



CUT PVC FOR WALL SLEEVE AT SLIGHT ANGLE

FIGURE 13

4. Place a field-provided plastic cover over the end of the pipe that will be visible from the inside wall and insert the pipe in the wall.

PVC WALL SLEEVE INSTALLATION

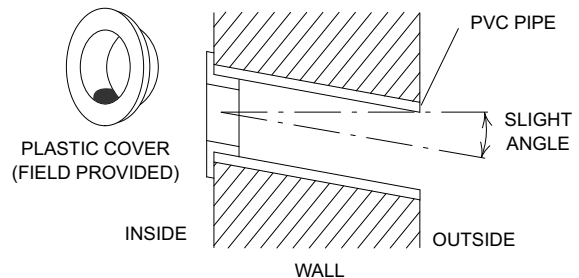

FIGURE 14

SECURE WALL MOUNTING BRACKET TO WALL

Determine that wall will support the weight of the indoor unit. See table 1 for indoor unit weight. Install the wall mounting bracket so that it is correctly positioned horizontally and vertically. The indoor unit must be installed level on the wall to allow proper condensate drainage.

1. Use a carpenter's level or tape measure to verify the wall mounting bracket is horizontally level.
2. Secure the wall mounting bracket to the wall using the provided screws. If possible, align the rear panel screw holes with wall stud locations marked on the wall.

HINT — Use the wall mounting bracket as a template to mark locations where screws will be used.

- Secure the wall mounting bracket to the wall using as many screws into studs as possible. All other screws must be secured using plastic wall anchors.

NOTE — It is important to use all screws provided to secure the wall mounting bracket to the wall. Additional holes may be drilled through the metal wall mounting bracket to better secure wall bracket to wall studs.

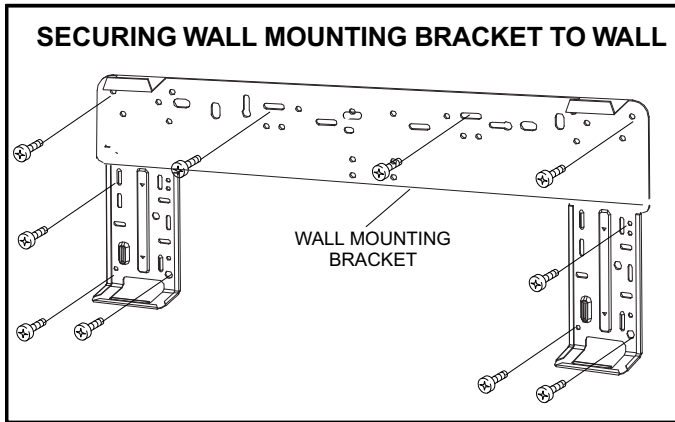

FIGURE 15

- The wall mounting bracket must be installed flush against the wall so that the indoor unit will be flush after installation. Any space between the wall and unit will cause noise and vibration.
- The wall mounting bracket must be installed horizontally level on the wall.
- If the wall is made of brick, concrete or other similar material, then drill pilot holes in the wall. Insert field-provided plastic anchors for mounting screws.

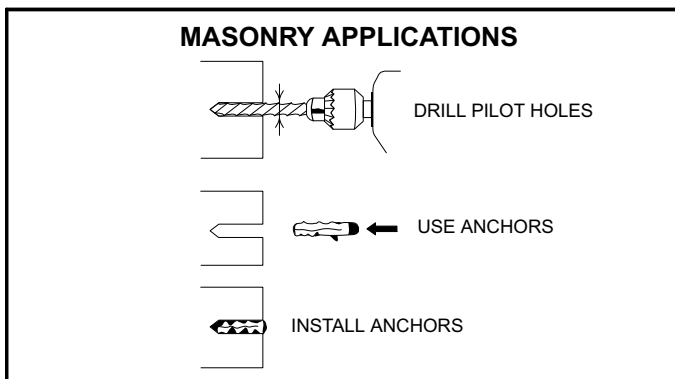

FIGURE 16

CONDENSATE DRAIN CONFIGURATION

If the condensate line needs to be moved, use the following procedure to change the drain line exit location.

NOTICE

Care must be taken when moving the condensate line to the opposite position to prevent damaging the condensate line or connector.

CHANGING CONDENSATE DRAIN LOCATION (IF NECESSARY)

- Locate the condensate line and the drain cap located on unit.
- Remove the clamp which secures the condensate line to the drain outlet and pull the line to remove it.
- Apply moderate force to pull off the drain cap from the unit.

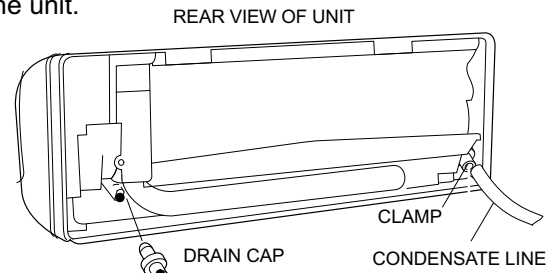

- Re-install the drain cap on the opposite side drain outlet.

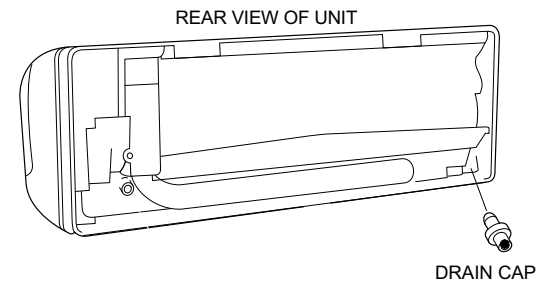

- Slide the condensate line over the opposite drain outlet and use the clamp to secure the line.

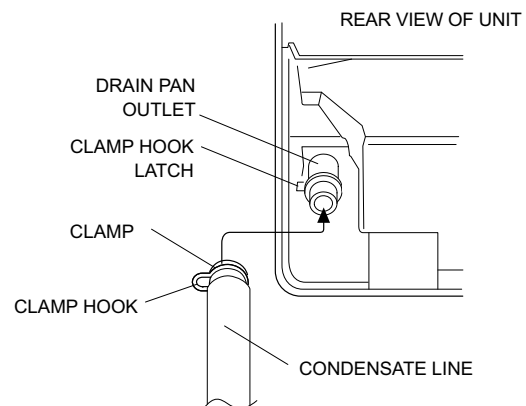

IMPORTANT — Keep horizontal runs of condensate line external to unit as short as possible. Condensate line should be properly sloped to ensure proper drainage.

FIGURE 17

PREPARING INDOOR UNIT FRAME FOR LEFT- OR RIGHT-SIDE EXIT OF UTILITY BUNDLE

- Right- or Left-Side Utility Bundle Exit** — Cut out the corner of the right/left plastic cabinet with a hacksaw or similar tool (A or B).

2. **Right-Rear or Left-Rear Utility Bundle Exit** — The corner of the plastic cabinet does not need to be modified.

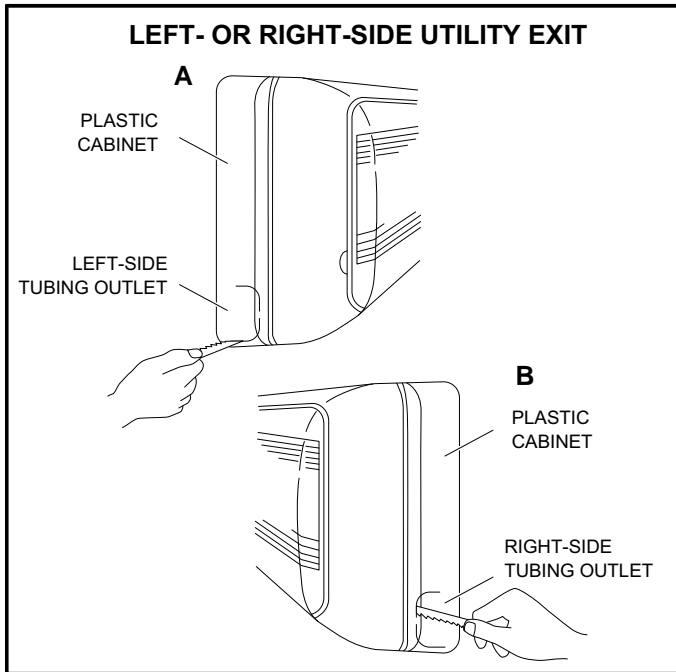

FIGURE 18

Indoor Unit Cable Connections

NOTE — Stranded wire must be used to connect the outdoor unit to the indoor unit. The stranded wire is necessary to ensure proper system communication and operation.

1. Route the cable (4-conductor, stranded wire, line voltage, sized per National Electric Code) through the wall sleeve. Refer to unit nameplate for rated voltage.

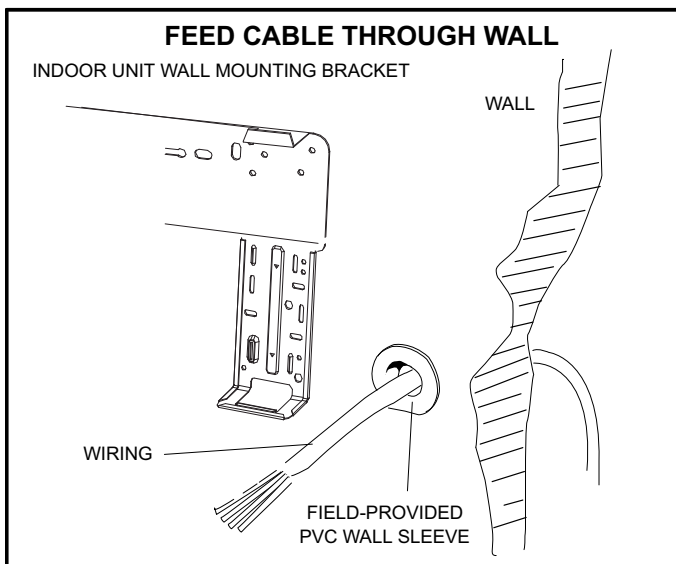

FIGURE 19

2. Make sure to provide a sufficient length of cable so that connections are made to the unit before it is secured to the wall mounting bracket.
3. Lift indoor unit front panel to access the control box cover. Remove the screw(s) securing the cover plate. Remove the plate.

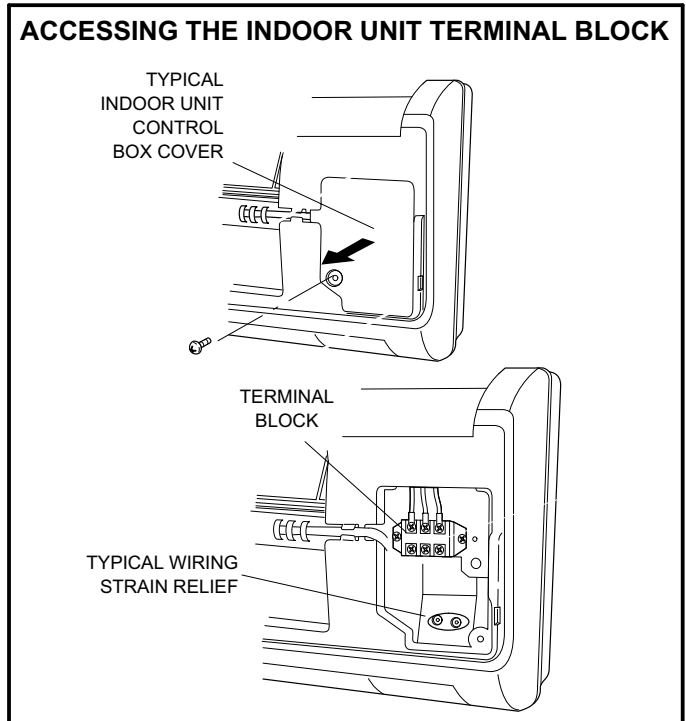

FIGURE 20

4. Feed cable / wiring through conduit routing guide.
- NOTE* — A cable routing guide has been factory-installed.

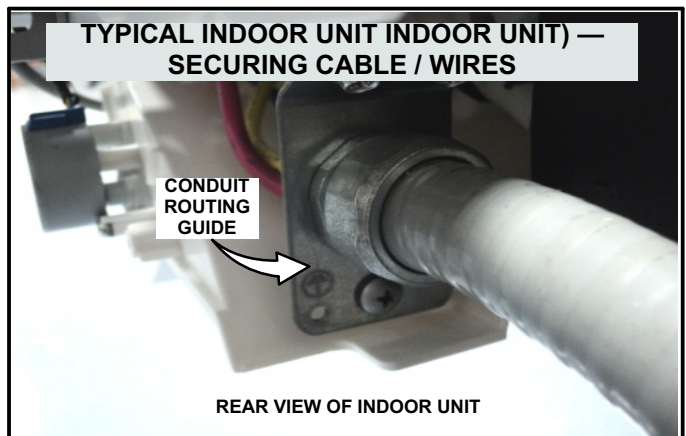

FIGURE 21

5. Strip the wire insulation to expose the stranded wire.
6. Tightly twist each wire end.
7. Terminal designations for the indoor unit terminal block are illustrated in figure 29.
8. Use the provided strain relief plate to secure the terminal block wiring.

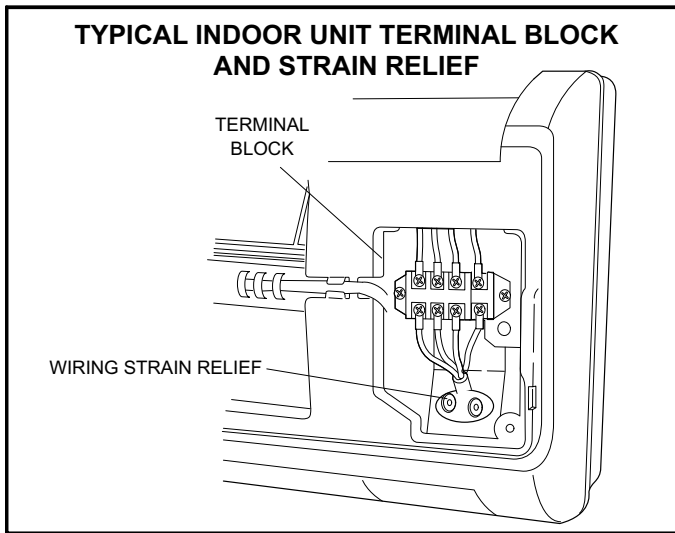

FIGURE 22

Securing Indoor Unit to Wall Mounting Bracket

1. Shape the refrigerant line set so that it can be guided either out the back of the indoor unit or through either side of the indoor unit frame, then through the wall sleeve to the outside unit.
2. Use field-provided tape to bundle the cable, refrigerant line set and condensate line together as shown in figure 1.
3. Feed the bundle through the wall sleeve and slide indoor unit onto upper mounting hooks.

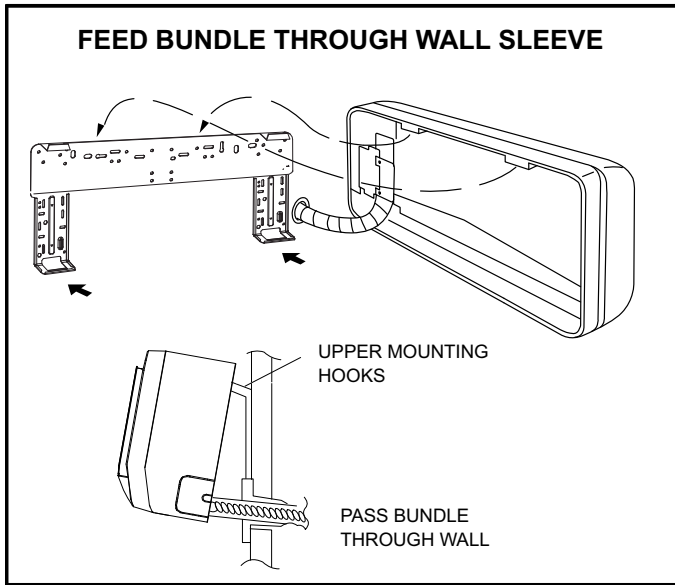

FIGURE 23

1. Secure the indoor unit to the wall bracket using the lower mounting hooks.

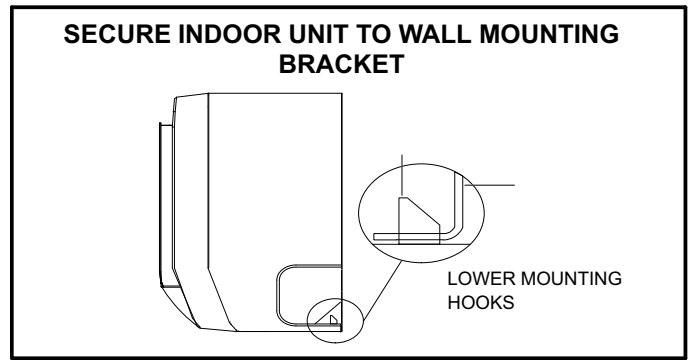

FIGURE 24

2. Carefully bend the bundle (line set, condensate line and cable) to run along the outside wall toward the outdoor unit. Downward slope of wall sleeve will ensure proper condensate drainage.

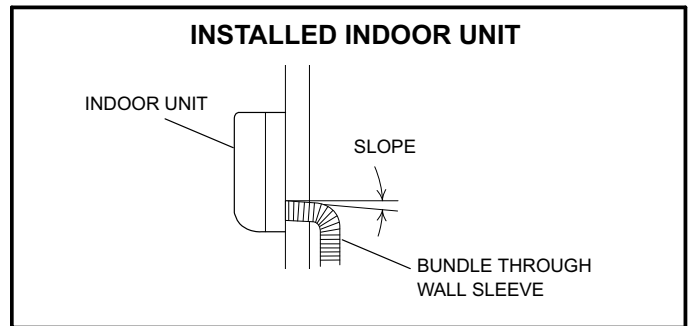

FIGURE 25

CONDENSATE LINE

1. Use the provided foam insulation to wrap the factory-installed condensate line.
2. Connect indoor unit factory-installed condensate line to field-provided condensate drain pipe.



FIGURE 26

3. Use tape approved for waterproofing line connections to secure the field-provided pipe to the factory-installed condensate line.

5. Secure wiring using built-in wire strain relief.



FIGURE 27

NOTE — Use a clean, **dry cloth** to wipe the indoor unit after installation is complete to remove fingerprints. Do not use wet cloth, cleansers or solutions.

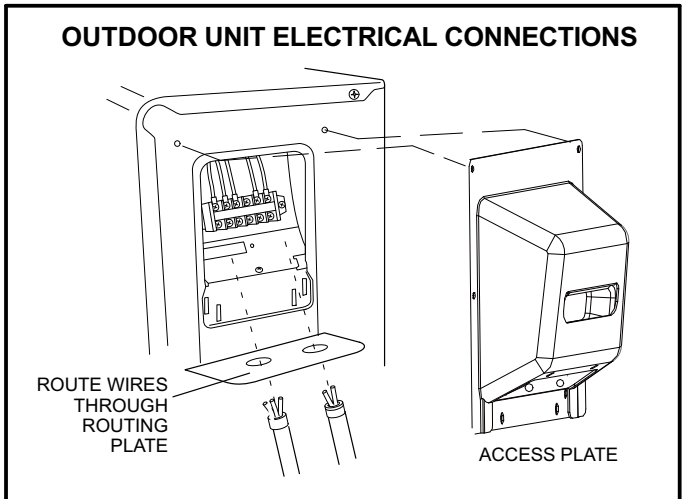

FIGURE 28

Outdoor Unit Wiring Connections

In the U.S.A., wiring must conform with current local codes and the current National Electric Code (NEC). In Canada, wiring must conform with current local codes and the current Canadian Electrical Code (CEC).

Refer to unit nameplate for minimum circuit ampacity and maximum overcurrent protection size.

MAIN SYSTEM CIRCUIT BREAKER AND OUTDOOR UNIT DISCONNECT SWITCH

The main system circuit breaker and outdoor unit disconnect switch should be sized per local codes and unit requirements.

Local codes may require a disconnect between the indoor and outdoor units.

INDOOR / OUTDOOR CABLE

Wiring must conform to local and national codes.

NOTE — Stranded wire must be used to connect the outdoor unit to the indoor unit. The stranded wire is necessary to ensure proper system communication and operation.

SUPPLY POWER

Size per unit nameplate and local and national codes.

WIRING CONNECTIONS

1. Remove access panel.
2. Route all wiring to outdoor unit through the wire routing plate.
3. Connect the control wiring and power supply wiring per the figures that follow.
4. The unit must be grounded according to local codes.

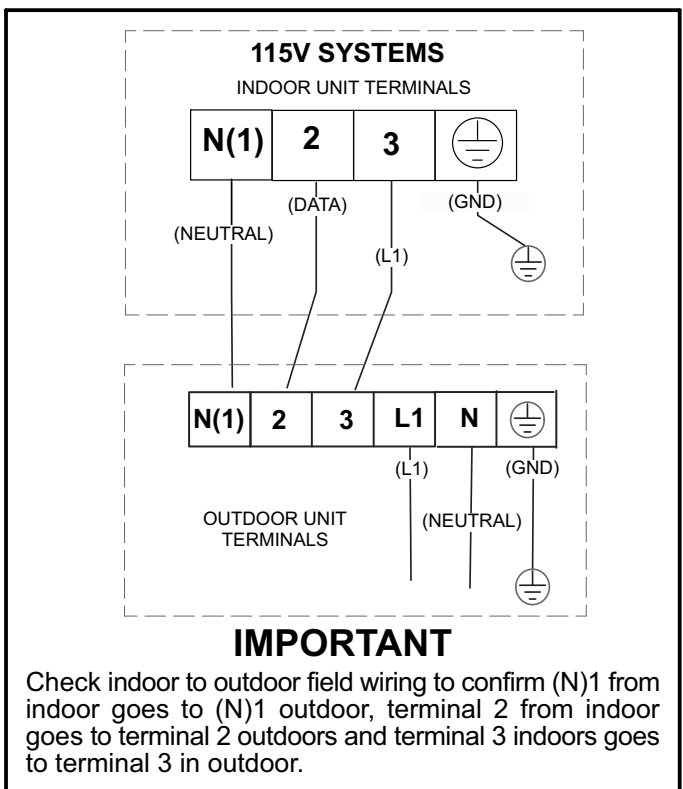

Figure 29. Unit Terminal Designations

6. Connect the green/yellow ground wire to the ground terminal.
7. Use the strain relief to secure the cabling (figure 30).

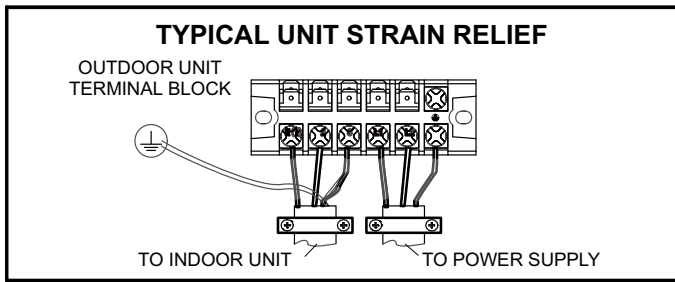

FIGURE 30

WIRING DIAGRAM SYMBOLS AND COLOR CODES

The following tables identify the wiring color codes and ground symbol used in the following wiring diagrams.

**TABLE 5
WIRE COLOR CODES**

CODE CODE	COLOR	COLOR CODE OR SYMBOL	COLOR
WH	WHITE	BN	BROWN
YE	YELLOW	BU	BLUE
RD	RED	BK	BLACK
YEGN	YELLOW GREEN		

**TABLE 6
SYMBOLS**

SYMBOL	PARTS NAME
L1	REACTOR (CHOKE)
PCB1-PCB2	PRINTED CIRCUIT BOARD
S10/S11S40/S70/S80/S90	CONNECTOR
SAT	OVERLOAD
COMP	COMPRESSOR

Operating Service Valves

The large line service valve on the outdoor unit is used to purge air, test for leaks, check operating pressures and add refrigerant to system. The large line valve is equipped with a service port which has a factory-installed valve core. Figure 32 provides information on how to access and operate the 3-way service and 2-way shut-off valves.

TIGHTENING SERVICE VALVE CAPS

To Access Service Port:

A service port cap protects the service port core from contamination and serves as the primary leak seal.

1. Remove service port cap with an appropriately sized wrench.
2. Connect gauge set to service port.
3. When testing is complete, replace service port cap and tighten as follows:

- * With torque wrench: Finger tighten and torque cap per table 4.
- * Without torque wrench: Finger tighten and use an appropriately sized wrench to turn an additional 1/6 turn clockwise.

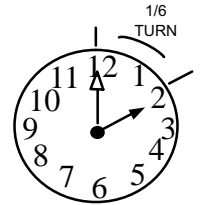

Reinstall Stem Cap:

Stem cap protects the valve stem from damage and serves as the primary seal. Replace the stem cap and tighten as follows:

- * With Torque Wrench: Finger tighten, then torque cap per table 4.
- * Without Torque Wrench: Finger tighten, then use an appropriately sized wrench to turn an additional 1/12 turn clockwise.

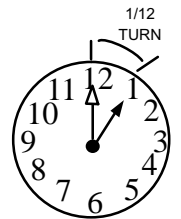

FIGURE 31

SERVICE VALVE OPERATION

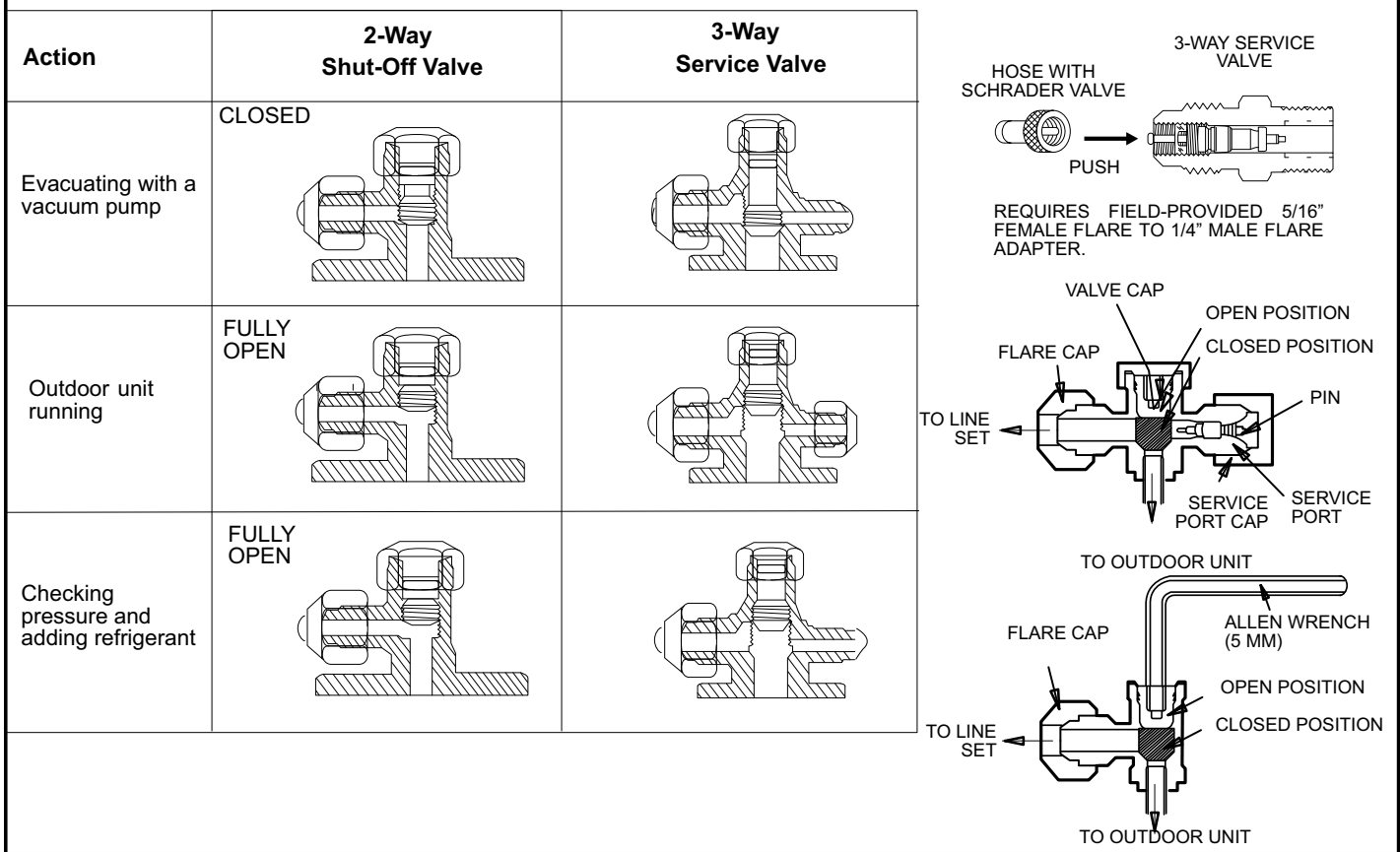

FIGURE 32

! IMPORTANT

To prevent stripping of the various caps, use an appropriately sized wrench and fit the wrench snugly over the cap before tightening.

USING MANIFOLD GAUGE SET

When checking the system charge, only use a manifold gauge set that features low-loss, anti-blow-back fittings.

Manifold gauge set used for HFC-410A refrigerant systems must be capable of handling the higher system operating pressures. The manifold gauges should be rated for:

- * High side — Pressure range of 0 - 800 pound-force per square inch gauge (psig)
- * Low side — Use with 30" vacuum to 250 psig with dampened speed to 500 psig
- * Manifold gauge set hoses must be rated for use up to 800 psig of pressure with a 4000 psig burst rating.

Line Set Requirements

This section provides information on installation of the field-provided line set.

LINE SET INSTALLATION

Field piping consists of two lines from the outdoor unit to the indoor unit. Use field-fabricated line set with flare connections and sizes as listed in table 9.

Seal and isolate the opening where the bundle (including refrigerant lines) passes through so vibration is not transmitted to the building. Pay close attention to line set isolation during installation of any HVAC system. When properly isolated from building structures (walls, ceilings, floors), the refrigerant lines will not create unnecessary vibration and subsequent sound. Line set must be insulated.

LINE SET LENGTH AND ELEVATION

Capacity is based on standard line set length and maximum allowable length and elevation (table 9).

Minimum line set length for all sizes is 10 feet (3 meters).

! IMPORTANT

Mineral oils are not compatible with HFC-410A.

LINE SET CONNECTIONS

Line connections are made to the outdoor unit using field-provided flare nuts.

Remove the service valve cover from the outdoor unit.

FLARING PROCEDURE

1. Use a tube cutter to cut the copper line set to the required length. Cut the lines approximately 12" to 20" (305 mm to 508 mm) longer than the estimated required length.
2. Use a pipe reamer or file to remove burrs at the end of the line set.
3. Remove flare nut from outdoor unit and slide it onto the copper tube.
4. Use a flaring tool to flare the end of the copper tube.

5. Remove flare nut from outdoor unit and slide it onto the copper tube.
6. Use a flaring tool to flare the end of the copper tube.

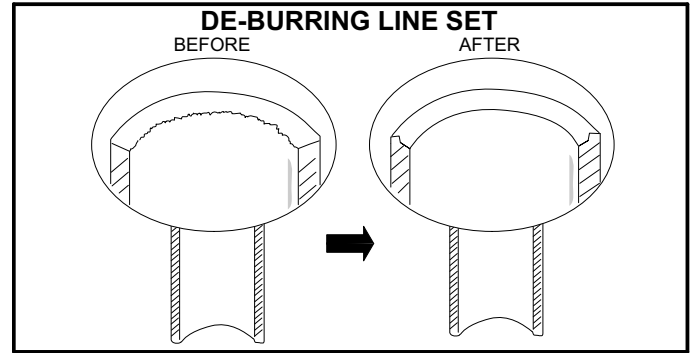

FIGURE 33

TABLE 7
REFRIGERANT LINE SET REQUIREMENTS, LENGTH AND HEIGHT LIMITATIONS AND OUTDOOR UNIT REFRIGERANT METERING DEVICE TYPE (AIR CONDITIONER AND HEAT PUMP SYSTEMS)

System Size (kBtu)	Recommended Line Set Diameters		Maximum Line Set Elevation	Maximum Line Set Length	Refrigerant Metering Device Type
	Small Line	Large Line			
-09	1/4 in. (6 mm)	3/8 in. (9.5 mm)	33 feet (10 m)	49 Feet (15 m)	Electronic Expansion Valve
-12				66 Feet (20 m)	

Note - Minimum line set length for all sizes is 10 feet (3 meters).

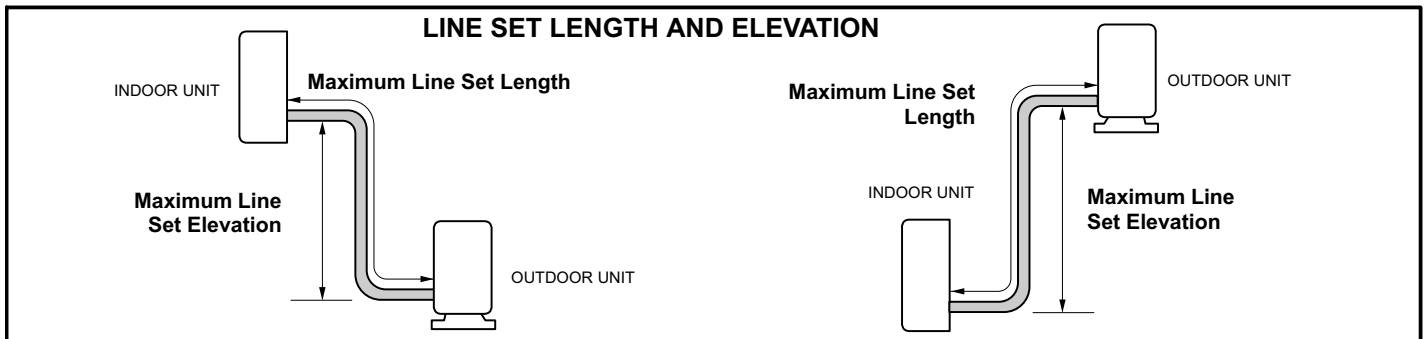

FIGURE 34

TABLE 8
FLARE NUT TORQUE RECOMMENDATIONS

Outside Diameter		Recommended Torque		No torque wrench available Finger tighten and use an appropriately sized wrench to turn an additional:	
Inches	mm	Imperial	Metric (Newton Meter)		
1/4"	6.35	15 ft.- lb.	20	1/4 turn	
3/8"	9.52	26 ft.- lb.	35	1/2 turn	
1/2"	12.70	41 ft.- lb.	55	7/8 turn	
5/8"	15.88	48 ft.- lb.	65	1 full turn	

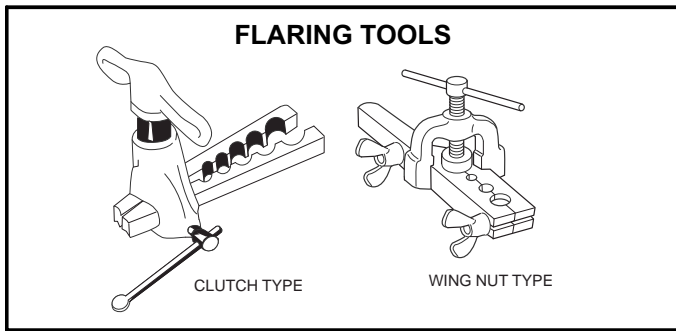

FIGURE 35

CONNECTING LINE SET TO OUTDOOR UNIT

1. Apply a sealing cap or water-proof tape to prevent dust or water from getting into the refrigerant piping before it is connected.
2. Apply refrigerant lubricant to the matching surfaces of the flared line set and union before connecting them together (figure 36 -- **A**). This will reduce refrigerant leaks.
3. Align the flared refrigerant line with valve connection, then tighten the flare nut lightly at first to obtain a smooth match (figure 36 - **B**).

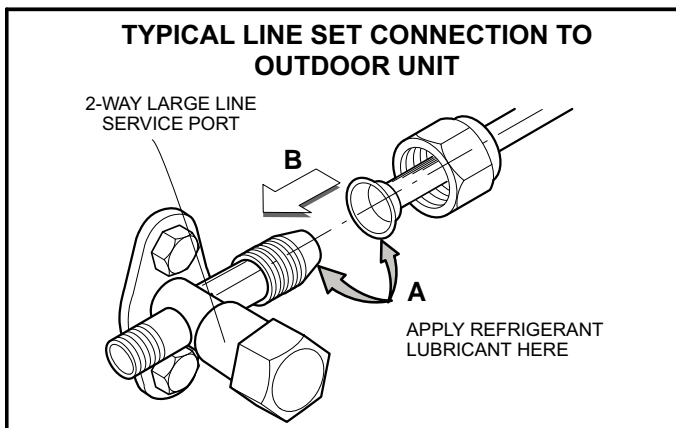

FIGURE 36

4. Tighten flare nuts. Do not over-tighten a flared joint. Once snug, continue another half turn on each nut. That should provide a gas-tight joint. You may also use a torque wrench to tighten nuts using table 8 recommendations.

CONNECTING LINE SET BETWEEN INDOOR AND OUTDOOR UNITS

1. Apply a sealing cap or water-proof tape to prevent dust or water from getting into the refrigerant piping before it is connected.
2. Apply refrigerant lubricant to the matching surfaces of the flared line set and union before connecting them together (figure 37 -- **A**).
3. Align the union tube and flared refrigerant line with each other, then tighten the flare nut lightly at first to obtain a smooth match (figure 37 -- **B**).

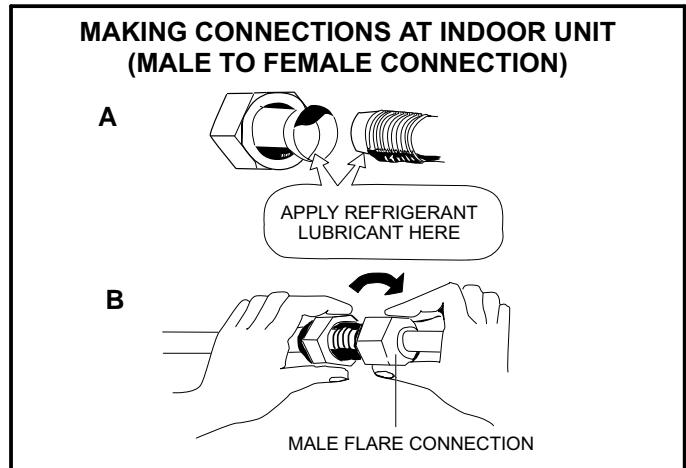

FIGURE 37

4. Tighten flare nuts. Do not over-tighten a flared joint. Once snug, continue another half turn on each nut. That should be a leak-free joint. You may also use a torque wrench to tighten nuts using table 8 recommendations.

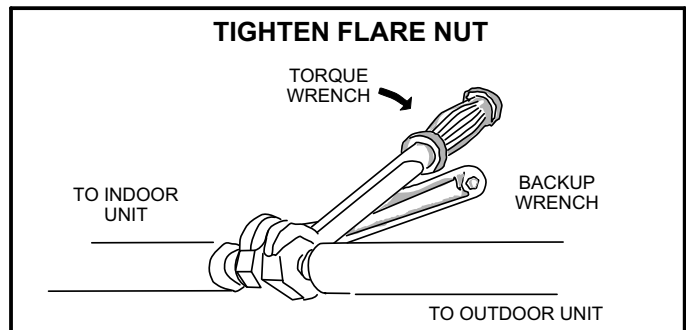

FIGURE 38

MANIFOLD GAUGE SET CONNECTIONS FOR LEAK TESTING, EVACUATION AND CHARGING

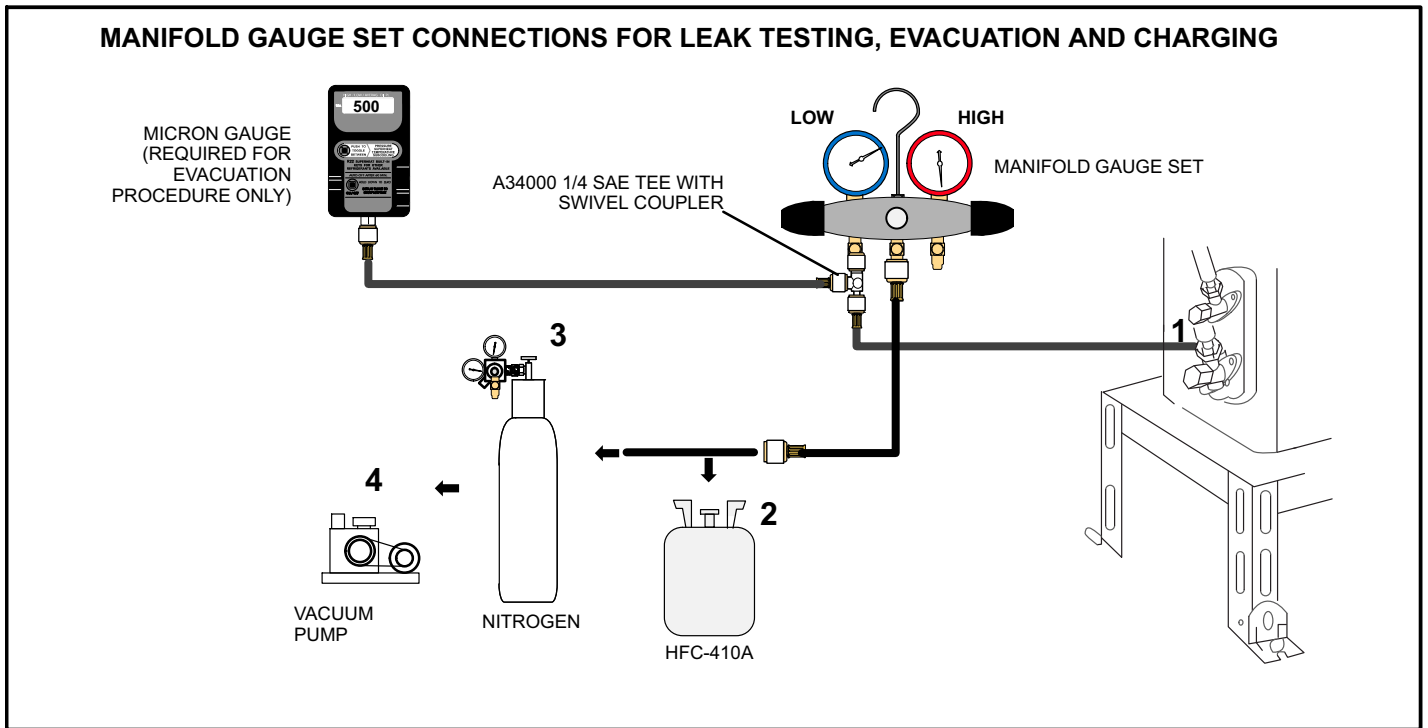

FIGURE 39

The line set between the indoor and outdoor unit must be leak tested and evacuated to remove any non-condensables and moisture from the system.

Leak Test and Evacuation

Air and moisture remaining in the refrigerant system will have undesirable effects as indicated below:

- * Pressure in the system rises
- * Operating current rises
- * Cooling or heating efficiency drops
- * Moisture in the refrigerant circuit may freeze and block capillary tubing (-30 size only)
- * Water may lead to corrosion of parts in the refrigeration system

The line set between the indoor and outdoor unit must be leak tested and evacuated to remove any non-condensables and moisture from the system.

LEAK TEST

1. Connect the manifold gauge set and dry nitrogen gas cylinder to the large line service port as illustrated in figure 39.
2. Pressurize the system to no more than 150 PSIG with dry nitrogen. Check for leaks using soapy water.
3. After the system is found to be free of leaks, relieve the nitrogen pressure by loosening the charge hose connector at the nitrogen cylinder. When the system pressure is reduced to normal, disconnect the hose from the cylinder.

EVACUATION

1. Connect the gauge set, micron gauge and vacuum pump as shown in figure 39.
2. The operation time for evacuation varies with the line set length and capacity of the pump. Allow the pump to operate until the system has been evacuated down to

300 microns. Allow the pump to continue running for an additional 15 minutes.

3. Turn off the pump and leave the connection secured to the 3-way service valve. After five minutes, if the system fails to hold 500 microns or less, check all connections for tight fit and repeat the evacuation procedure.
4. When the desired vacuum is reached, close the low knob of the manifold valve and stop the vacuum pump.

Unit Start-Up

⚠ IMPORTANT

If unit is equipped with a crankcase heater, it should be energized 24 hours before unit start-up to prevent compressor damage as a result of slugging.

UNIT START-UP

1. Inspect all factory- and field-installed wiring for loose connections.
2. Verify that the manifold gauge set is connected as illustrated in figure 39.
3. Open the 3-way service and 2-way shut off valves to release the refrigerant charge contained in outdoor unit into the system.
4. Replace the stem caps and tighten to the value listed in table 4.
5. Check voltage supply at the outdoor unit terminal strip. The voltage must be within the range listed on the unit's nameplate. If not, do not start the equipment until you have consulted with the power company and the voltage condition has been corrected.
6. Refer to the included user guide to operate the system using the provided remote control.
7. Visually check for binding of both indoor and outdoor fans.

Adding Refrigerant for Longer Line Set

! IMPORTANT

FV50S PVE is the **ONLY** acceptable oil for Lennox MS7 and MS8 mini-split systems.

Polyvinylether (PVE) is an innovative refrigerant oil specially formulated for hydrofluorocarbon (HFC) refrigeration systems. In addition to providing lubricating properties, it also has a number of other applied advantages that help to increase the reliability of the refrigeration systems where it is applied.

1. Open the low side manifold gauge valve and weigh in liquid refrigerant. Use table 9 to calculate the correct weigh-in charge.
2. Close manifold gauge valves.

Checking Large Line Operating Pressures

Use table 9 as a general guide when performing maintenance checks. This is not a procedure for charging the unit. Minor variations in these pressures may be expected due to differences in installations.

**TABLE 9
LINE SET LENGTH AND ADDING REFRIGERANT**

System Size (kBtu)	Base Charge (outdoor unit is sufficient for up to listed length below)	Add Refrigerant
-09	26 feet (8 m)	1 ounces per 40 inches (30 grams per meter)
-12		

Temperature Condition °F (°C)		System Size (kBtu)	Indoor Fan Mode	Outdoor Fan Mode	Standard Operating Pressure Ranges	Line Set Length
Indoor	Outdoor					
Cooling Mode (Air Conditioners and Heat Pumps)						
67 to 80 (19.4 to 26.7)	75 to 95 (23.9 to 35)	09K	Turbo	High	116 to 160 PSIG (0.8 to 1.1 MPa)	26 feet (8 m)
		12K	Turbo	High	116 to 145 PSIG (0.8 to 1.0 MPa)	
Heating Mode (Heat Pump Only)						
60 to 70 (15.6 to 21.1)	43 to 47 (6.11 to 8.33)	09K	Turbo	High	406 to 464 PSIG (2.8 to 3.2 MPa)	26 feet (8 m)
		12K	Turbo	High		

1. If the operating pressures do not fall within the ranges given in the above table:
 - A. Check the indoor unit display for error code(s).
 - B. See troubleshooting procedure diagrams in this manual to verify proper component operation.
2. If no issues are found, follow the **weigh-in** charging procedure below to charge the system.

USING HFC-410A WEIGH-IN METHOD

Amount specified on nameplate Adjust amount. for variation in line set length listed in table 9 Total Charge

_____ + _____ = _____



NOTE — The above nameplate is for illustration purposes only. Go to actual nameplate on outdoor unit for charge information.

FIGURE 40

Wrapping Bundle

After system has been tested for leaks and proper operation has been verified, use tape to bundle the control wiring, line set and condensate line.

1. Wrap insulation material around the line set connection between the indoor and outdoor units.
2. Insulate remaining sections of line set and condensate line.

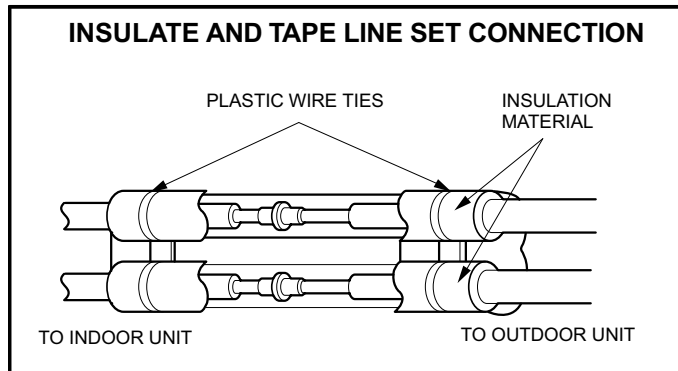

FIGURE 41

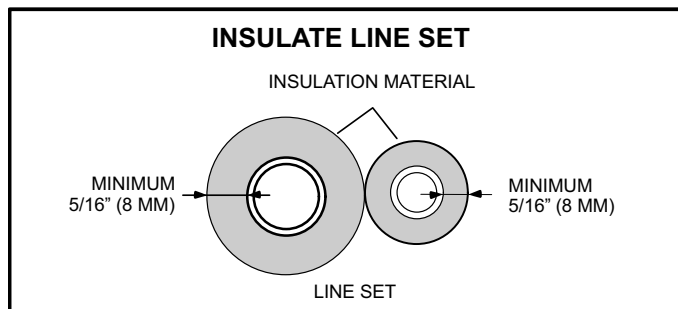

FIGURE 42

3. Start from the bottom at the outdoor unit and use tape to bundle the insulated line set together with tape (figure 43).

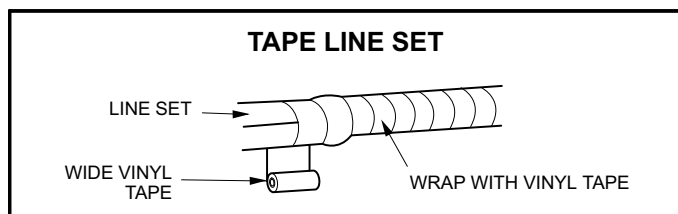

FIGURE 43

CONTROL WIRING BUNDLING

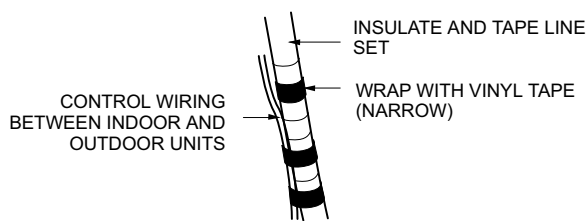

FIGURE 44

4. Tape the control wiring to the line set bundle (figure 44).
5. Start from the bottom of the bundle at the outdoor unit and use tape to bundle the condensate line with the control wiring and line set (figure 45).

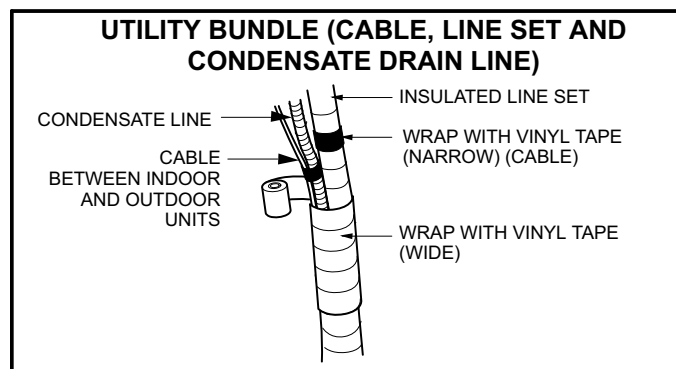

FIGURE 45

1. Clamp bundle to wall. Use one clamp approximately every 47" (1194 mm).
2. Apply sealant around the utility bundle on the outside of the wall sleeve to prevent rain and outdoor air from entering the room.

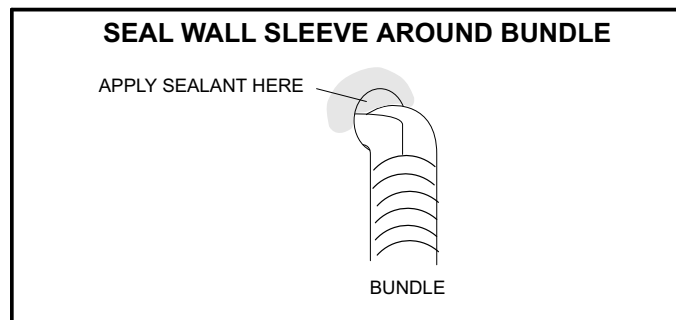

FIGURE 46

3. An optional field-provided exterior wall channel may be used in lieu of taping the utility bundle (see figure 47) to protect the bundle from UV rays, weather, etc.

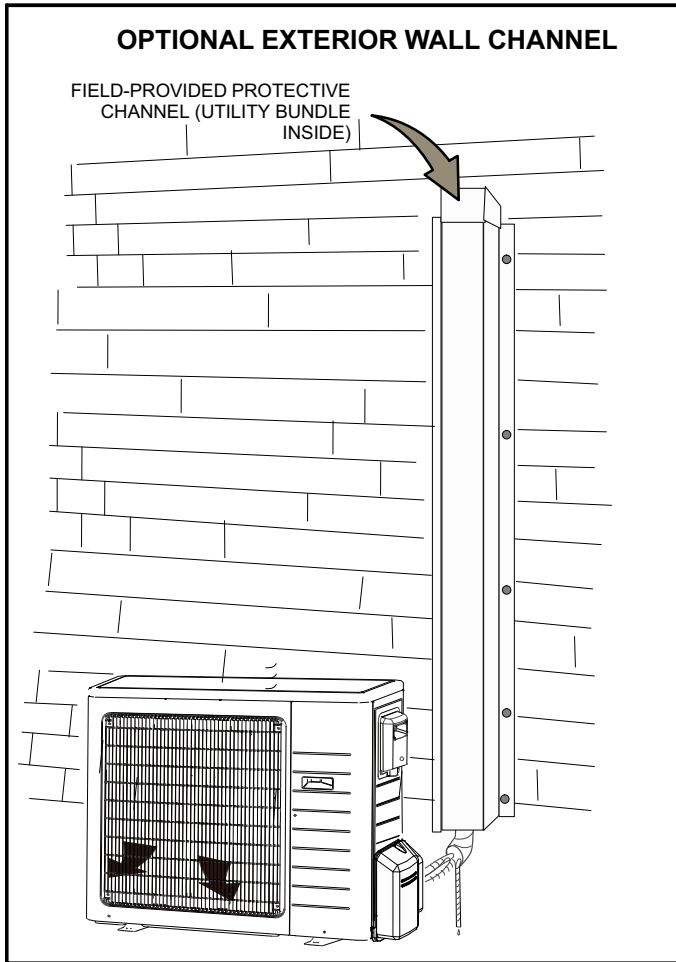

FIGURE 47

Maintenance

OUTDOOR UNIT

1. Ensure power is off before cleaning.
2. It may be necessary to wash the outdoor coil more frequently if it is exposed to substances which are corrosive or which block airflow across the coil (e.g., pet urine, cottonwood seeds, fertilizers, fluids that may contain high levels of corrosive chemicals such as salts).
3. Outdoor Coil (Sea Coast) — Moist air in ocean locations can carry salt, which is corrosive to most metal. Units that are located near the ocean require frequent inspections and maintenance. These inspections will determine the need to wash the unit including the outdoor coil. Consult your installing contractor for proper intervals/procedures for your geographic area or service contract.
4. Outdoor unit fan motor is pre-lubricated and sealed. No further lubrication is needed.
5. Visually inspect all connecting lines, joints and coils for evidence of oil leaks.
6. Check all wiring for loose connections.
7. Check for correct voltage at unit (unit operating).

INDOOR UNIT

1. Clean or change filters.
2. Check all wiring for loose connections
3. Check for correct voltage at unit (blower operating).
4. Clean coil, if necessary.
5. Check connecting lines and coils for signs of oil leaks.
6. Check condensate line and clean, if necessary.

NOTE— The filter must be in place and the front panel must be closed any time the unit is in operation.

III. OPERATING THE WIRELESS REMOTE

Wireless Remote Functions

The wireless remote control provides system control to the homeowner at the touch of a button. The indoor unit and remote control send information back and forth continuously. The remote control must be placed on a table or other surface in direct line of sight with the indoor unit infrared receiver. The remote control should not be placed in a drawer. Make sure that there are no obstructions between the indoor unit receiver and the remote control. Do not drop the control or spill liquid on the remote control.

POWER button

Press this button once to turn system on. Press again to turn the system off. When the POWER button is used to turn the system OFF, it overrides the Sleep Timer function (when it is in use).

+/- buttons

Use plus (+) and minus (-) buttons to adjust the temperature setting up and down.

NOTE - The temperature cannot be adjusted when the system is in AUTO mode.

FAN button

Press this button to select fan speed. AUTO fan is the default setting. In AUTO fan mode, the indoor fan speed is determined by the indoor ambient temperature. Press FAN button to step through FAN setting selections: AUTO, low speed, medium speed and high speed. Selected fan speed is shown at the top of the remote control display.

AUTO Low Medium High

*NOTE - The fan speed is not adjustable during DEHUMIDIFICATION mode operation. **The low fan speed is necessary to ensure optimal humidity control.***

MODE button

Press this button to select system operating modes. AUTO mode is the default setting. Press MODE button again to select COOL mode, again for DEHUMIDIFICATION mode, again for FAN mode and again for HEAT mode (heat pumps only).

Selected mode is displayed on both remote and indoor unit cover panel.

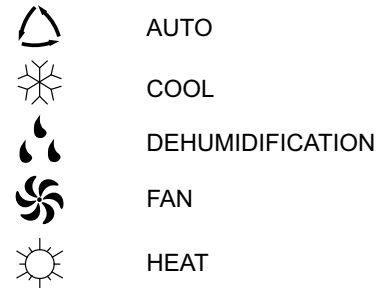

I FEEL button

Press the I FEEL button to activate the I FEEL feature. When the I FEEL icon appears, temperature sensor in remote control is used to initiate heating or cooling demands. Press I FEEL button again to cancel I FEEL feature and transfer room temperature sensing back to sensor in indoor unit.

UNUSED buttons

These buttons are not functional in the MS8 system.



Wireless Remote Functions (Continued)

SWITCH FROM °C TO °F

With system OFF, press MODE and - buttons simultaneously to switch from Centigrade to Fahrenheit. Current selection is displayed to the right of the temperature display.

CLOCK button

Use the CLOCK button to adjust the time displayed on the remote control. Press the CLOCK button once. The clock icon  will flash. Within 2 seconds, use the - and + buttons to adjust the time down or up in one-minute increments. Press the button continuously to adjust the time in 10-minute increments. Press the CLOCK button again when correct time is displayed.

BLOW button

Use the BLOW button to extend low speed blower operation for 10 minutes at the end of a cooling demand.

The extended fan (BLOW) operation ensures that excess moisture is removed from the indoor coil before the blower shuts off.

Press the BLOW button once to initiate extended blower operation. Fan operation ends after 10 minutes.

The extended fan (BLOW) operation icon  is displayed when the feature is turned on.

Extended fan (BLOW) operation is available in cooling or dehumidification modes; extended fan (BLOW) operation is not available in AUTO, heating or fan mode.

LOUVER SETTING button

See page 27 for complete details on louver operation.

SLEEP button

Use the SLEEP button to initiate or cancel the sleep function. Press SLEEP button. When sleep icon  appears, press TIMER OFF button and use - and + buttons to set time for system shutdown. When desired time is displayed, press TIMER OFF button again. Press SLEEP button to cancel sleep function. In cooling mode, SLEEP function increases temperature (+1.8°F per hour) over a two-hour period after the selected sleep time. In heating mode, SLEEP function decreases temperature (-1.8°F per hour) over a two-hour period after the selected sleep time.

NOTE - The sleep function is not available in AUTO or FAN modes.

TURBO button

Use the TURBO button to initiate or cancel high-speed fan operation to accelerate cooling or heating of the ambient room temperature. The turbo icon  is displayed when the function is turned on.





Wireless Remote Functions (Continued)

LOUVER SETTING button

Use the LOUVER SETTING button to choose a preferred setting for the indoor unit directional louver.

NOTE - Actual louver position is different than what is shown on remote icon. See comparison to the right.

Press the LOUVER SETTING button  once to activate the full-range oscillation mode from top to bottom, then back again. The louver icon  will appear in the lower section of the screen.

Press the LOUVER SETTING button again to turn the feature OFF. The louver will return to the default setting.

Press the LOUVER SETTING button twice and continue to press the button to scroll through the five available fixed positions

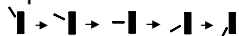

AND three other oscillating positions.





To return the louver to the default position, press the LOUVER SETTING button until the icon  disappears.

Default Louver Positions

When the louver setting icon is not displayed, the louver is in the DEFAULT position.







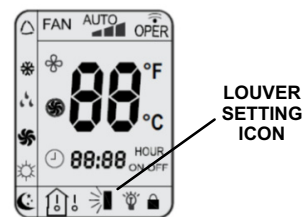

When the remote control is powered OFF, the default position is fully closed.

When the remote control is set so that the unit is in COOLING, AUTO COOLING, or DEHUMIDIFICATION mode, the louver is in a fixed upward position .

When the remote control is set so that the unit is in HEAT or AUTO HEATING mode and the outdoor unit is OFF, the louver is fixed in the second position  pointed upward. If the outdoor unit is ON, the louver is fixed in a downward position .

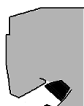
When the remote is set for continuous indoor fan to be ON, the louver is fixed in an upward position .

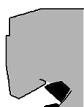

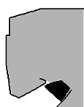
REMOTE CONTROL ICON POSITION	ACTUAL LOUVER POSITION
	
	
	
	
	

TIMER ON button

Use the TIMER ON button to initiate or cancel a single timed-on event. Use this feature to bring the system on just before you return home or just before you wake in the morning.

Press the TIMER ON button once. The clock icon  disappears and a time setting appears with the word ON flashing at the right. Use the - and + keys to adjust the time setting to the desired time for the system to begin operation. Press the TIMER ON button again to accept the setting. When successfully set, the word ON will appear to the right of the current time display. Press the TIMER ON button again if you want to cancel the timed-on event.

TIMER OFF button

Use the TIMER OFF button to initiate or cancel a single timed-off event. Use this feature to turn the system off just after you leave the house or just after you go to bed at night.

Use the same method described above to set the desired time for the system to stop operation. When successfully set, the word OFF will appear to the right of the current time display. Press the TIMER OFF button again if you want to cancel the timed-off event.





REMOTE LOCK

Press - and + buttons simultaneously to either lock or unlock the remote control buttons. When locked, the  icon is displayed.

TEMP button

Use the TEMP button to change the temperature display shown on the remote control. When initially powered on, the current temperature setting is displayed, along with the  icon.

Press the TEMP button once to alter the display to show the current indoor ambient temperature, along with the  icon. The indoor temperature sensor is in the indoor unit.

Press the TEMP button again to display the outdoor ambient temperature  icon. The outdoor ambient temperature display is not available on this system.

On occasion, the remote control will display the temperature that was not selected (indoor ambient temperature or setting temperature). The selected temperature will return to the display screen after 5 seconds.

NOTE - The TEMP button can also be used to temporarily display the indoor ambient temperature on the indoor unit display panel.

LIGHT button

Use the LIGHT button to turn the indoor unit display light on and off. When the light is on, the  icon appears on the remote control.

System Start Up Using Wireless Remote

General Operation

- 1 - Press POWER button once to turn system on.
- 2 - Press MODE button until desired operating mode icon is displayed.



NOTE - When AUTO mode is selected, the temperature setting is not displayed on the remote control. The - and + buttons cannot be used to make temperature setting selections.

- 3 - Press - or + buttons until desired temperature setting is displayed.

NOTE - Skip this step in AUTO mode.

- 4 - Press FAN button until desired fan speed icon is displayed.

NOTE - Fan speed will be set to low if DEHUMIDIFICATION mode has been selected.

- 5 - Press  OSCILLATE button. Indoor unit directional louver will open and begin to oscillate. If a single setting is preferred, press  button again when louver is in the desired position. Louver will remain in desired position until system is powered off.

Special Functions

- 6 - Press SLEEP button to initiate sleep function. Then press TIMER OFF button to set timed off.
- 7 - Use TIMER ON and TIMER OFF buttons to schedule desired timed on and off settings.
- 8 - Use LIGHT button to set display light on or off.
- 9 - Use BLOW button to turn on and off extended fan operation feature.
- 10 - Use TURBO button to turn accelerated fan speed on or off.
- 11 - Use I FEEL button to use temperature sensor in remote control to initiate cooling and heating demands.



Remote Control Batteries

The wireless remote control requires two AAA, 1.5V batteries. DO NOT attempt to use any other type of battery.

Follow the steps below and in the illustrations to replace the batteries when necessary.

- 1 - Remove screw that secures the battery access panel to the remote. Place thumb on  at the top of the battery access panel on the back of the remote control. Slide the panel in the direction of the arrow.
- 2 - Remove the existing AAA, 1.5V batteries.
- 3 - Replace batteries with fully charged AAA, 1.5V batteries. NOTE - Pay attention to proper polarity of batteries. Remote control will not operate if batteries are improperly installed.
- 4 - Reposition battery access panel and slide forward until panel snaps into locked position. Reinsert screw.

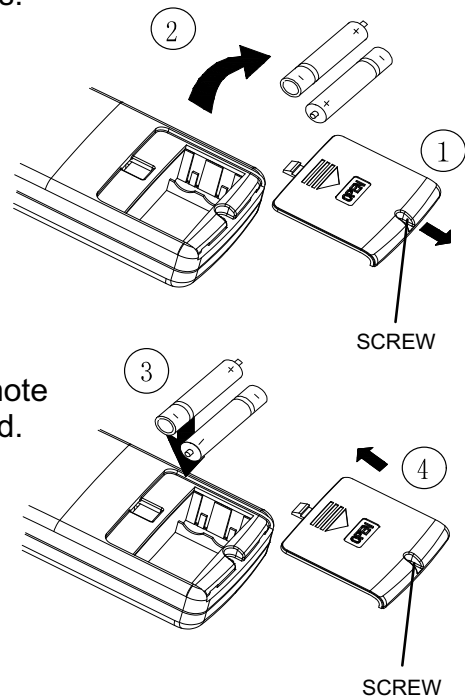

IMPORTANT !

- If wireless remote will not be used for a long period of time, remove batteries to avoid damage to the control.
- To verify that the remote control is transmitting commands to the indoor unit, press any command key and a wireless icon  will appear in the upper right-hand corner of the remote control display.
- When being used in the I FEEL mode, the remote control must be placed on a table or other surface in direct line of sight with the indoor unit infrared receiver. The control should not be placed in a drawer. Make sure that there are no obstructions between the indoor unit receiver and the remote control.
- Remote should remain within its receiving range to ensure proper system control. Control should be kept at least 3 feet (914mm) away from other electrical appliances (televisions, stereos, etc.) to prevent signal interference.
- If remote control operation becomes erratic, remove batteries. Wait 30 seconds and reinsert batteries. If proper remote operation is not restored, replace batteries.

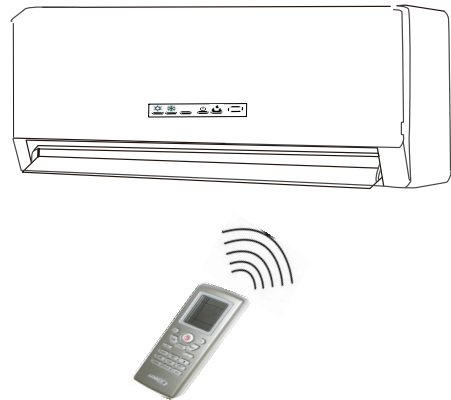

Auto ON Switch

If the remote control is lost or damaged, or if charged AAA, 1.5V batteries are not available, the Auto ON switch can be used to turn the system on or off.

The Auto ON switch is located behind the cover panel on the indoor unit. Lift the front panel and press the ON button once briefly to start the system. To stop emergency operation, push the ON button again.

IMPORTANT !

The Auto ON button initiates operation in the AUTO mode. The temperature and fan speed are not adjustable in the AUTO mode.

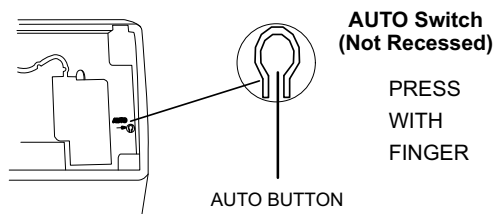
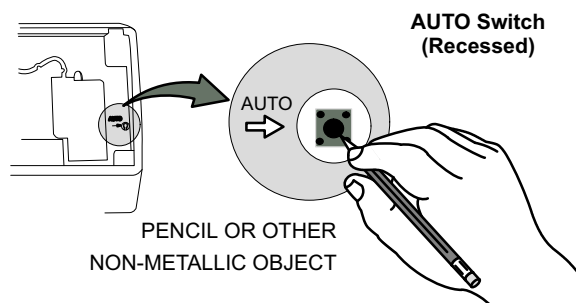

WARNING!

Turn off all power to unit at system disconnect switch (at the outdoor unit) or circuit breaker before performing any maintenance procedures! Failure to follow this warning could lead to personal injury or death.

Coil fins are very sharp! Take care not to touch the fins in order to avoid injury.

Indoor Unit Filters

The indoor unit filter should be cleaned every three months, or more frequently, if necessary.

Follow the steps below and in the illustrations to clean the filters.

- 1 - Pivot indoor unit front panel out and up to access filters.
- 2 - Gently pull each filter outward, then down to remove the filters from the unit
- 3 - Use a vacuum cleaner to remove dust and dirt from each filter or wash the filters with warm water and a mild detergent. Rinse filters thoroughly with clean water and set aside to air dry.

CAUTION!

Do not use hot water to clean the filters. Exposure to water temperatures above 113°F (45°C) will damage filter media and frame.

- 4 - Reinsert clean, dry filters and close unit front panel. Restore power to unit.

Indoor Unit

Check to make sure that there are no objects on top of unit or around unit that may be obstructing air flow. Check to make sure that indoor unit and wall bracket are secure and have not been damaged. Use a clean, dry cloth to gently remove dust from the outer surface of the indoor unit. The cloth may be slightly dampened with warm water, if necessary. Do not use soap or other cleaners.

CAUTION!

Hot water, soaps or other cleaning agents may damage indoor unit cabinet or display panel. Do not use hot water (above 113°F [45°C]). Cloth must be damp only (NEVER WET) to avoid damage to display. Do not use soap or other cleaning agents (window cleaner, abrasive cleansers, etc.) to clean the indoor unit cabinet.

Outdoor Unit

Check to make sure that there are no objects on top of unit or around unit that may be obstructing air flow. If the outdoor unit is installed on a wall bracket, make sure that bracket is secure and has not been damaged. Use a clean, slightly dampened cloth to gently remove dust from the outer surface of the outdoor unit. Do not use soap or other cleaners and DO NOT spray water into unit.

WARNING!

SHOCK HAZARD! DO NOT SPRAY water into outdoor unit. Failure to follow this warning could lead to electrical shock, resulting in personal injury or death.

Lennox recommends annual inspection by a licensed professional service technician, or equivalent.

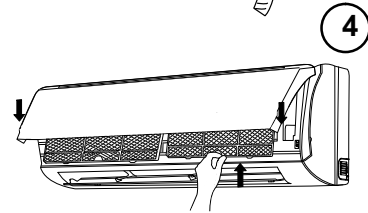
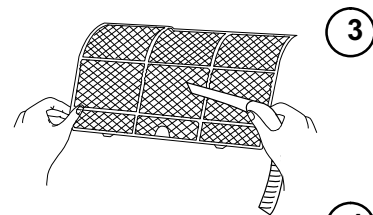
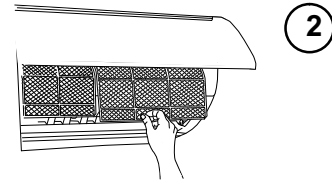
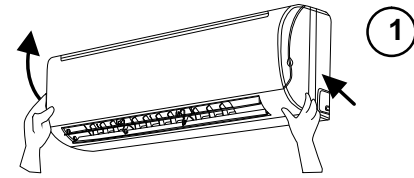

IV. SYSTEM OPERATION AND SERVICE

SYSTEM OPERATIONAL MODES

Air conditioner systems have four modes of operation. Heat pumps have five operational modes. These modes are:

- * Auto
- * Cooling
- * Dehumidification
- * Fan
- * Heat (HP model only)

AUTO MODE

Auto Mode - Non-adjustable indoor temperature set points are 68°F and 77°F (20°C and 25°C)

NOTE — Reversing valve is de-energized in cooling mode and energized in heating mode..

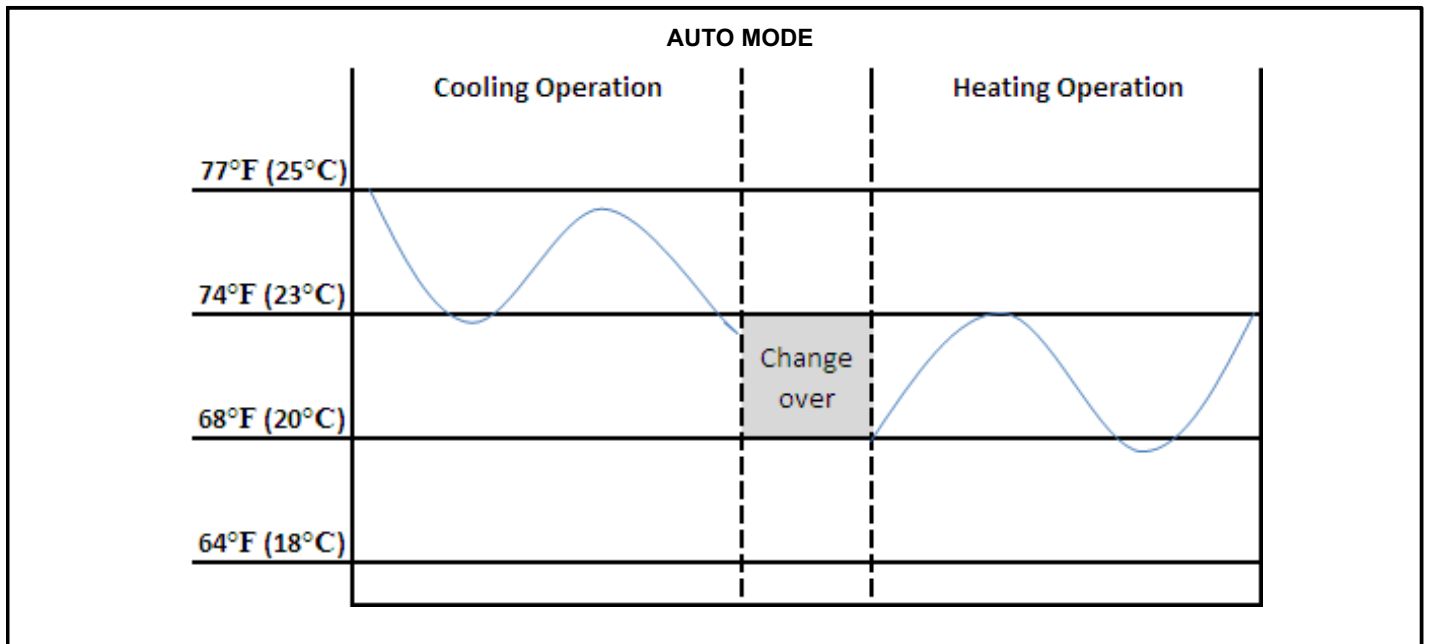

FIGURE 48

Protective Functions

Delays that normally protect the compressor are disabled during defrost cycles:

1. Minimum three (3) minute compressor time delay between operating cycles.
2. Minimum six (6) minute compressor run time between operating cycle.

Auto — Cool

If room ambient temperature is equal to or greater than 77°F (25°C), the unit cycles cooling **ON**. When the room ambient temperature is equal to or less than 77°F (25°C) minus 3.6°F (2°C), the compressor will cycle **OFF**, the outdoor fan will cycle **OFF** 60 seconds later. The indoor fan will run continuously at a preset speed until system has a heating demand or Auto Mode is switched **OFF**.

Auto — Heat

If room temperature is equal to or less than 64°F (18°C) plus 3.6°F (2°C), the heating will cycle **ON** when room temperature is equal to or greater than 64°F (18°C) plus 9.0°F (5°C), the compressor will cycle **OFF**. The outdoor fan will cycle **OFF** 60 seconds later. The indoor fan will cycle **OFF** after 60 seconds on low speed.

COOLING MODE (I FEEL MODE OFF)

Cool Mode - Indoor temperature set point range is 61°F and 86°F (16°C and 30°C)

NOTE — Reversing valve is de-energized in cooling mode.

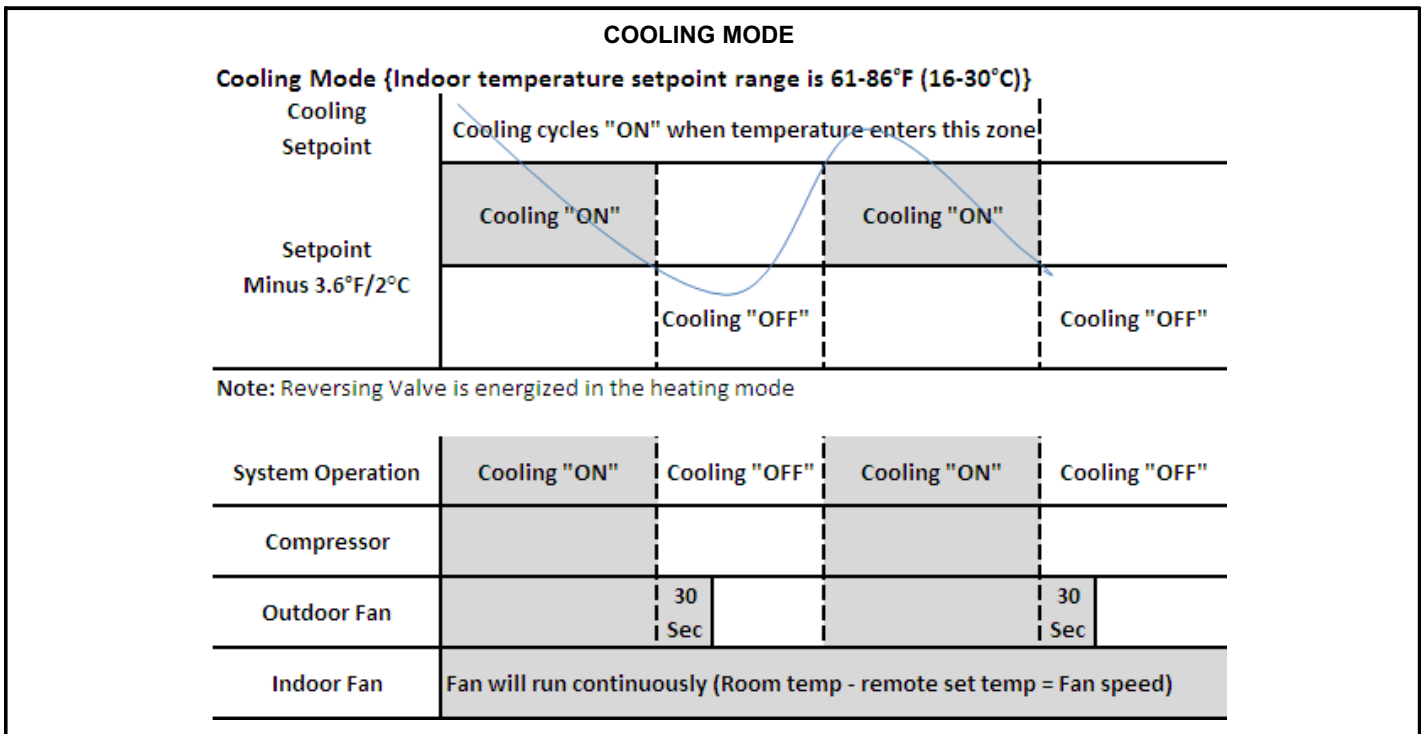

Protective Functions

Delays that normally protect the compressor are disabled during defrost cycles:

1. Minimum three (3) minute compressor time delay between operating cycles.
2. Minimum six (6) minute compressor run time between operating cycle.

Cool ON

If room ambient temperature is equal to or greater than the remote control set point, the unit cycles cooling **ON**.

Cool OFF

If room temperature is equal to or less than remote control set point minus 3.6°F (2°C), the compressor will cycle **OFF**. The outdoor fan will cycle **OFF** 30 seconds later. The indoor fan will continue to operation.

Indoor Fan Operation - Cooling

1. The indoor fan runs continuously.
2. The fan speed is determined by the difference between the room ambient temperature and the remote set point temperature.

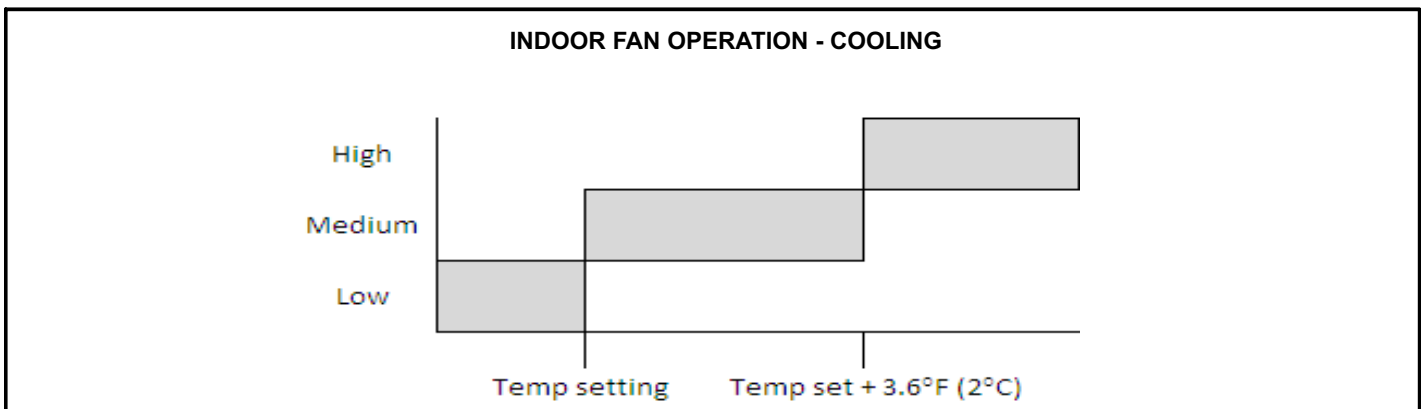

FIGURE 50

COOLING MODE (I FEEL MODE ON)

Cool Mode - Indoor temperature set point range is 61°F and 86°F (16°C and 30°C)

NOTE — Reversing valve is de-energized in cooling mode.

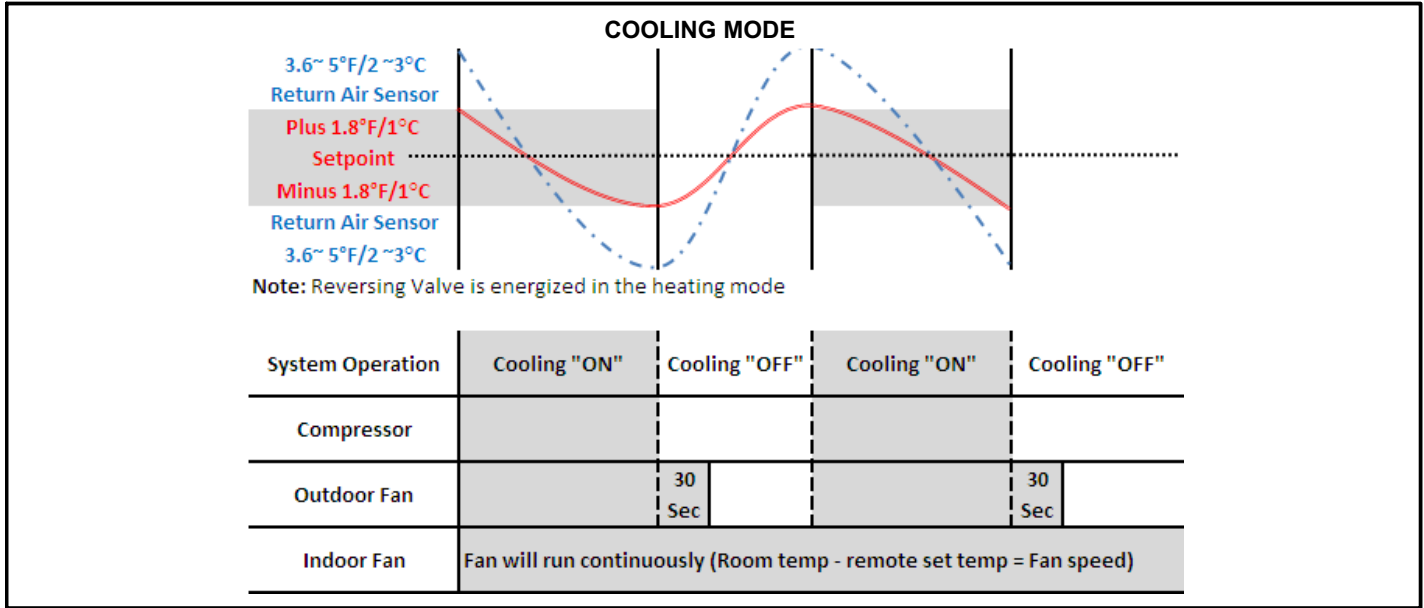

FIGURE 51

Protective Functions

Delays that normally protect the compressor are disabled during defrost cycles:

1. Minimum three (3) minute compressor time delay between operating cycles.
2. Minimum six (6) minute compressor run time between operating cycle.

I FEEL Mode

The indoor unit will cycle the system to maintain the remote control temperature setting. The remote control will send its temperature setting to the indoor unit every 10 minutes. If the indoor unit does not receive the remote control signal after 11 minutes, the system will revert back to maintaining the setting of the return air sensor. If main power is interrupted to system, **I FEEL** mode will need to be reset by turning the **I FEEL** mode **OFF** and **ON**.

NOTE - For I FEEL mode to work, infrared eye on remote must be aimed at indoor front panel.

Cool ON

If room ambient temperature is equal to or greater 1.8°F (1°C) than the remote control setpoint, the unit cycles cooling **ON**.

Cool OFF

If room temperature is equal to or less than remote control setpoint minus 1.8°F (1°C), the compressor will cycle **OFF**. The outdoor fan will cycle **OFF** 30 seconds later. The indoor fan will continue to operation.

Indoor Fan Operation - Cooling

1. The indoor fan runs continuously.
2. The fan speed is determined by the difference between the room ambient temperature and the remote set point temperature.

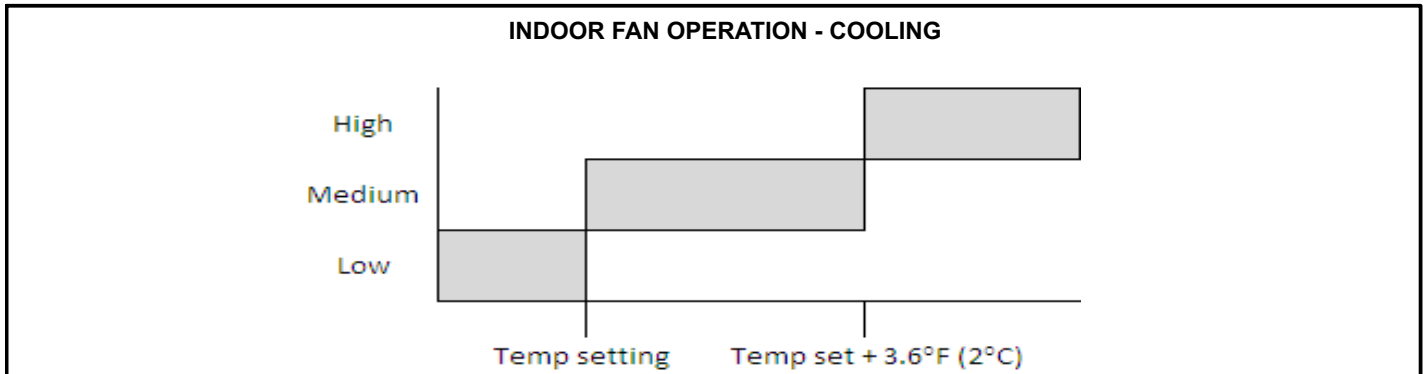

FIGURE 52

DEHUMIDIFICATION MODE (I FEEL MODE OFF)

Dehumidification Mode - Indoor temperature set point range is 61° and 86°F (16°C and 30°C)

DEHUMIDIFICATION MODE

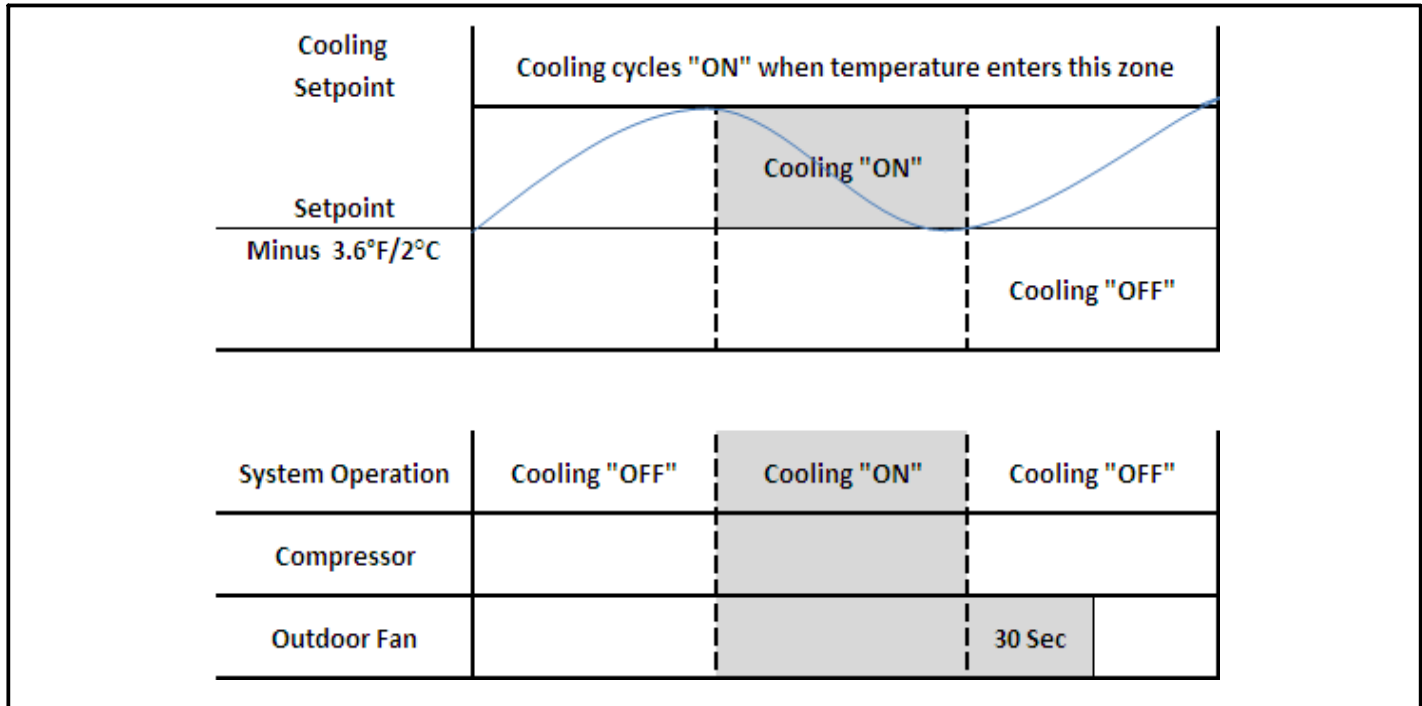

FIGURE 53

Protective Functions

Delays that normally protect the compressor are disabled during defrost cycles:

1. Minimum three (3) minute compressor time delay between operating cycles.
2. Minimum six (6) minute compressor run time between operating cycle.

Cool ON

If room ambient temperature is equal to or greater than the remote control set point, the unit cycles cooling **ON**.

Cool OFF

If room temperature is equal to or less than remote control set point minus 3.6°F (2°C), the compressor will cycle **OFF**. The outdoor fan will cycle **OFF** 30 seconds later. The indoor fan will continue to operation.

Indoor Fan Operation - Dehumidification

The indoor fan runs continuously at **low speed**.

FAN MODE

The indoor fan will run at a present speed and the compressor, outdoor fan and reversing valve (heat pump only) will be off.

DEHUMIDIFICATION MODE (I FEEL MODE ON)

Dehumidification Mode - Indoor temperature set point range is 61°F and 86°F (16°C and 30°C)

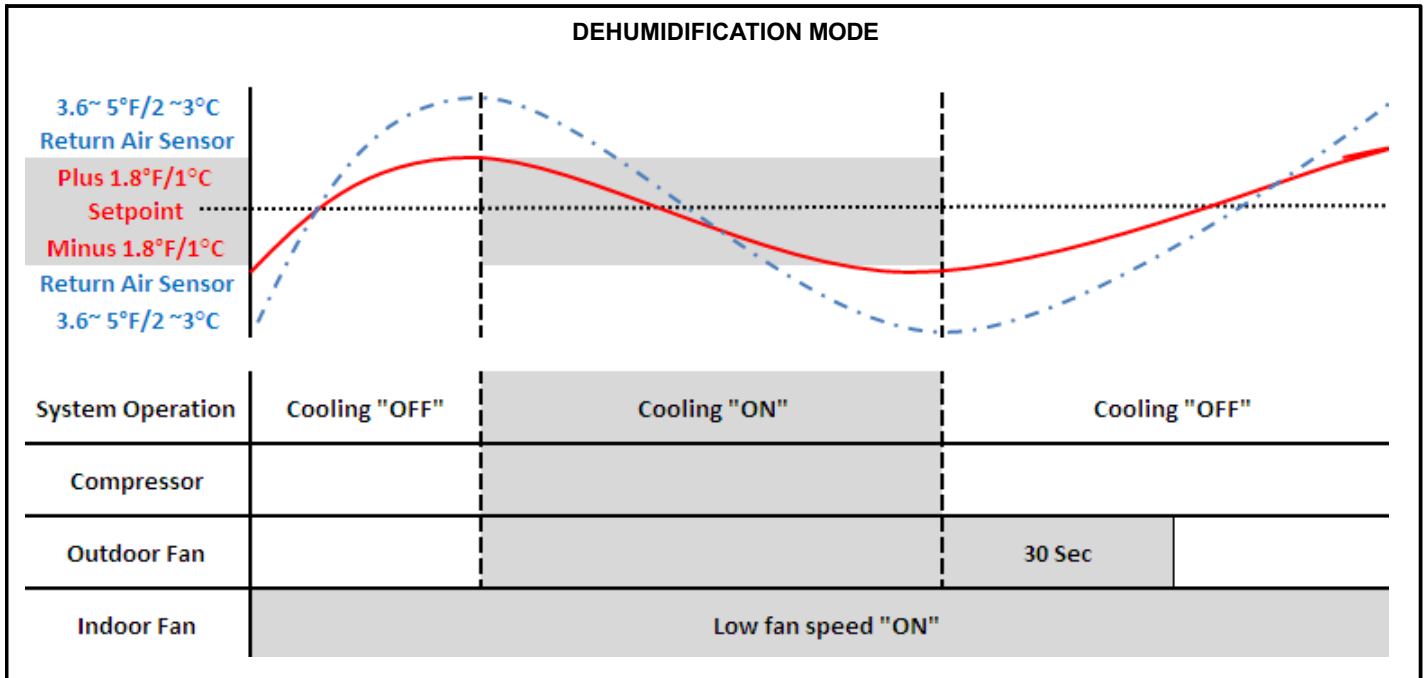

FIGURE 54

Protective Functions

Delays that normally protect the compressor are disabled during defrost cycles:

1. Minimum three (3) minute compressor time delay between operating cycles.
2. Minimum six (6) minute compressor run time between operating cycle.

Cool ON

If room ambient temperature is equal to or greater than the remote control set point, the unit cycles cooling **ON**.

Cool OFF

If room temperature is equal to or less than remote control set point minus 3.6°F (2°C), the compressor will cycle **OFF**. The outdoor fan will cycle **OFF** 30 seconds later. The indoor fan will continue to operation.

Indoor Fan Operation - Dehumidification

The indoor fan runs continuously at **low speed**.

FAN MODE

The indoor fan will run at a present speed and the compressor, outdoor fan and reversing valve (heat pump only) will be off.

HEAT MODE (I FEEL MODE OFF)

Heat Mode - Indoor temperature set point range is 61°F and 86°F (16°C and 30°C)

NOTE — Reversing valve is energized in heating mode.

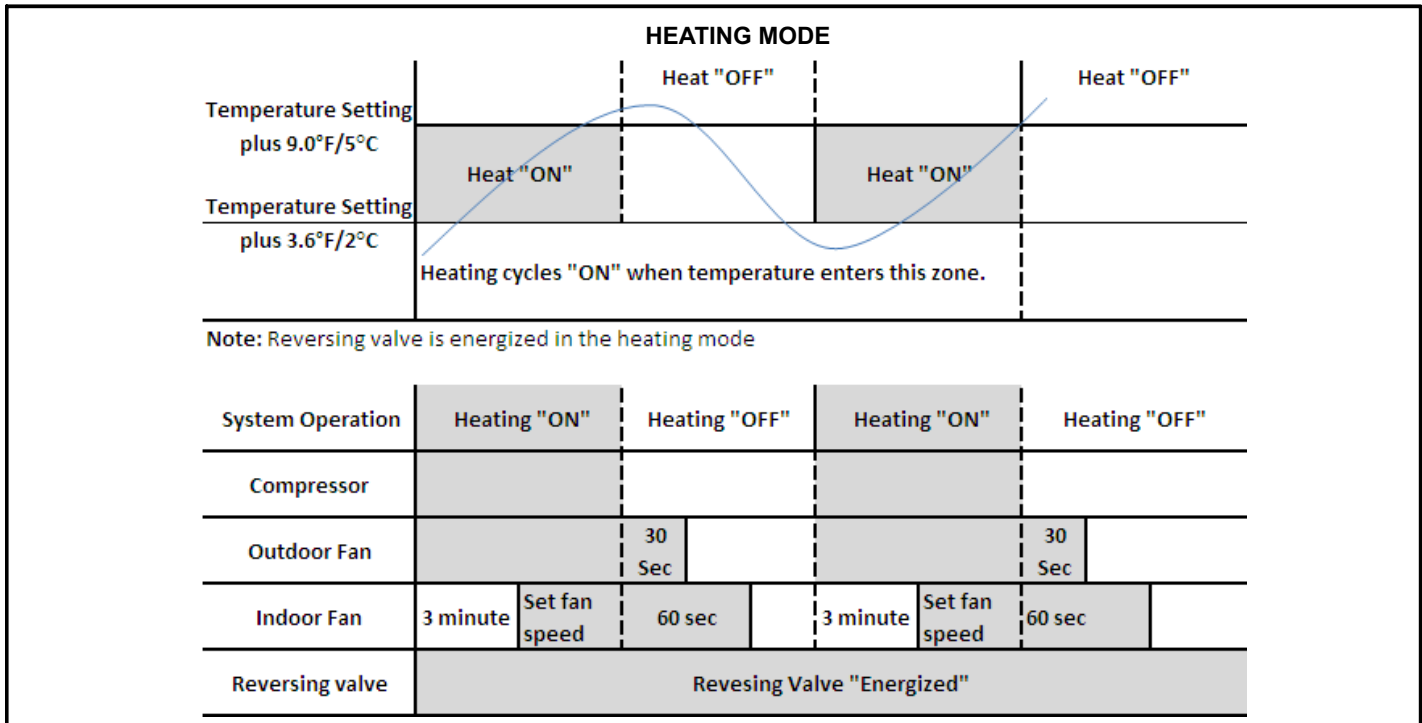

FIGURE 55

Protective Functions

The compressor is protected delays:

1. Minimum three (3) minute compressor time delay between operating cycles.
2. Minimum six (6) minute compressor run time between operating cycle.

Heat ON

If room ambient temperature is equal to or greater than the remote control set point plus 3.6°F (2°C), the unit cycles heat **ON**. If it has been three (3) minutes since the last heat demand, the compressor and outdoor fan will cycle **ON**. The indoor fan will operate according to the cold blow prevention function.

Heat OFF

If room temperature is equal to or less than remote control set point plus 9°F (5°C), the compressor will cycle **OFF**. The outdoor fan will cycle **OFF** 30 seconds later. The indoor fan will operate for 60 seconds after heat cycles **OFF**.

Indoor Fan Operation - Heating

The fan speed is determined by the difference between the room ambient temperature and the remote set point temperature.

Cold Blow Prevention

The system prevents cold air from blowing into space during heating operation. After three (3) minute time delay, one of the following indoor fan cycles will occur:

- * If the indoor ambient temperature is **greater** than 75°F (24°C): If the coil temperature is equal to or greater than 104°F (40°C) the indoor fan will run at low speed for 1 to 2 minutes. If during that time the coil temperature rises above 106°F (42°C), the indoor fan will ramp to a preprogrammed heat speed for those conditions.
- * If the indoor ambient temperature is less than 75°F (24°C): If the coil temperature is equal to or greater than 106°F (42°C) the indoor fan will run at low speed and within one minute, the indoor fan will ramp to preprogrammed heat speed for those conditions.

Reversing Valve Operation

The reversing valve is energized in heating and will stay energized for 2 minutes after the compressor is de-energized. The reversing valve is energized 2 seconds before the compressor is energized.

HEAT MODE (I FEEL MODE ON)

Heat Mode - Indoor temperature set point range is 61°F and 86°F (16°C and 30°C)

NOTE — Reversing valve is energized in heating mode.

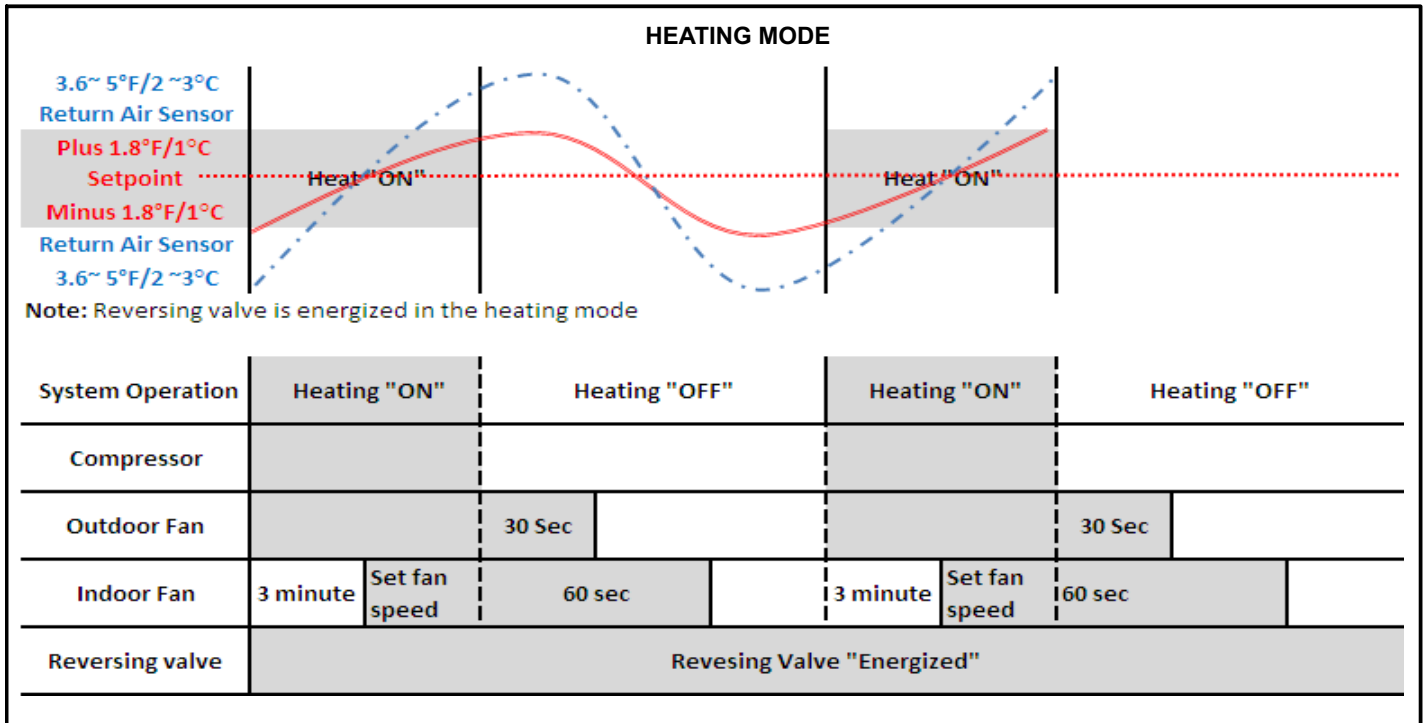

FIGURE 56

Protective Functions

The compressor is protected delays:

1. Minimum three (3) minute compressor time delay between operating cycles.
2. Minimum six (6) minute compressor run time between operating cycle.

Heat ON

If room ambient temperature is equal to or less than the remote control setpoint - 1.8°F (1°C) the unit cycles heating **ON**. If it has been 3 minutes since the last heating demand, the compressor and outdoor fan motor will cycle **ON**. The indoor fan will operate according to the Cold Blow Prevention function.

Heat OFF

If room temperature is equal to or greater than remote control setpoint + 1.8°F (1°C), the compressor will cycle **OFF**. The outdoor fan will cycle **OFF** 30 seconds later. The indoor fan will operate for 60 seconds after heating cycles **OFF**.

Indoor Fan Operation - Heating

The fan speed is determined by the difference between the room ambient temperature and the remote set point temperature.

Cold Blow Prevention

The system prevents cold air from blowing into space during heating operation. After three (3) minute time delay, one of the following indoor fan cycles will occur:

- * If the indoor ambient temperature is **greater** than 75°F (24°C): If the coil temperature is equal to or greater than 104°F (40°C) the indoor fan will run at low speed for 1 to 2 minutes. If during that time the coil temperature rises above 106°F (42°C), the indoor fan will ramp to a preprogrammed heat speed for those conditions.
- * If the indoor ambient temperature is less than 75°F (24°C): If the coil temperature is equal to or greater than 106°F (42°C) the indoor fan will run at low speed and within one minute, the indoor fan will ramp to preprogrammed heat speed for those conditions.

Reversing Valve Operation

The reversing valve is energized in heating and will stay energized for 2 minutes after the compressor is de-energized. The reversing valve is energized 2 seconds before the compressor is energized.

DEFROST MODE (HEAT PUMP ONLY)

The front panel indicator will display an H1 code when the system is in defrost. The system will perform as indicated in the figure 57.

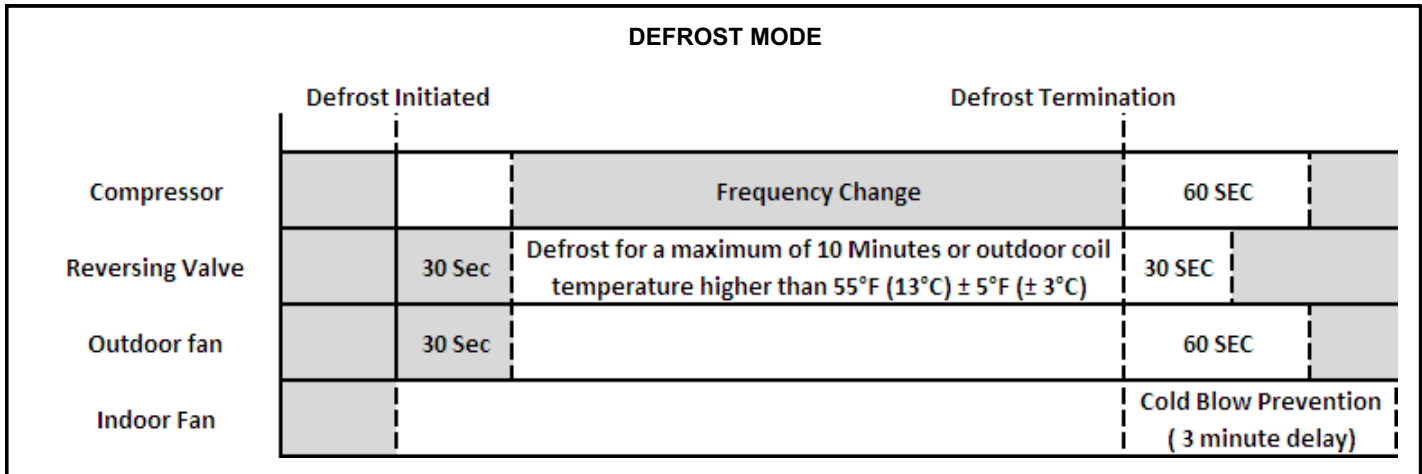

FIGURE 57

Protective Functions

1. There is no three (3) minute minimum compressor time off delay between operating cycles.
2. There is no six (6) minute minimum compressor operating cycle.

Defrost Initiation

Defrost is controlled by the microprocessor and will initiated when

- * System is in heating mode,
- * System has been running for at least six (6) minutes, or
- * Successive heating operations of more than 45 minutes or accumulated heating time more than 90 minutes.
- * One of the conditions listed under defrost termination that last longer than three (3) minutes.

Defrost Termination

Defrost is controlled by the microprocessor and will be terminated when

- * Outdoor coil temperature goes above 55°F (13°C) ± 5°F (± 3°C)
- * Defrost time is a maximum of ten (10) minutes.

Cold Blow Prevention

The system prevents cold air from blowing into space during heating operation. After three (3) minute time delay, one of the following indoor fan cycles will occur:

- * If the indoor ambient temperature is **greater** than 75°F (24°C): If the coil temperature is equal to or greater than 104°F (40°C) the indoor fan will run at low speed for 1 to 2 minutes. If during that time the coil temperature rises above 106°F (42°C), the indoor fan will ramp to a preprogrammed heat speed for those conditions.
- * If the indoor ambient temperature is less than 75°F (24°C): If the coil temperature is equal to or greater than 106°F (42°C) the indoor fan will run at low speed and within one minute, the indoor fan will ramp to preprogrammed heat speed for those conditions.

Defrost Test Function

When the unit is in Heat mode and set temperature is 61 F (16 C), press "+, -, +, -, +, -" successively for 5 seconds. The indoor and outdoor unit will enter defrost test function.

SYSTEM FUNCTIONS

These systems have several functions which are address in this section.. These functions are:

- * Sleep
- * Turbo
- * Cold Blow Prevention (Heat Pumps Only)

SLEEP

Cooling or Dehumidification — Sleep Function

When sleep function has been set, the set point will be increased by 1.8°F (1°C) after the sleep function has run for one hour and increased another 1.8°F (1°C) after two hours. The set point will be increased by a total of 3.6°F (2°C) during a single two hour period of operation. No further temperature adjustments will be made for the remainder of the sleep function.

Heating — Sleep Function

When sleep function has been set, the setpoint will be decreased by 1.8°F (1°C) after the sleep function has run for one hour and will be decreased another 1.8°F (1°C) after two hours. The set point will be decreased by a total of 3.6°F (2°C) during a single two hours period of operation. No further temperature adjustments will be made for the remainder of the sleep function.

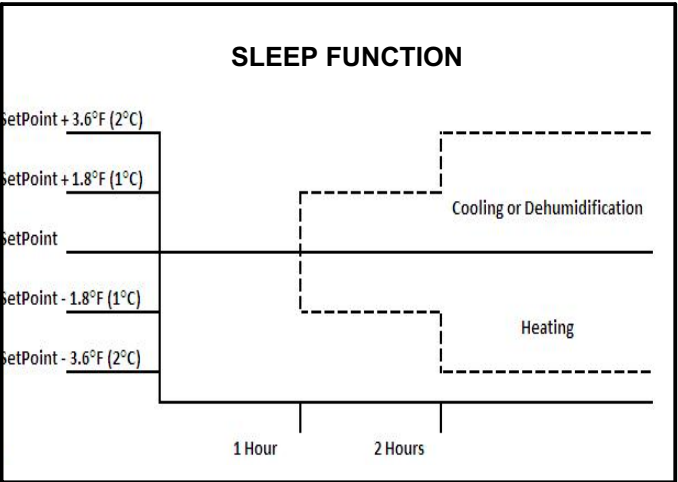

FIGURE 58

TURBO

When turbo function is activated, the indoor fan speed and compressor frequency (speed) is increased to maximize the delivery of cooled or heated air to the space.

**TABLE 10
TURBO FUNCTION**

Operational Mode	Maximum Fan Speed	Compressor Speed
Cool	Maximum Speed	Increase compressor speed
Dehumidification	No Change	No Change
Heat	Maximum Speed	Increase compressor speed
Fan	No Change	No Change
Auto	No Change	No Change

COLD BLOW PREVENTION

This function prevents cold air from blowing into space in heating mode. After a three (3) minute time delay, one of the following two indoor fan cycles occurs:

1. When the following conditions are meet:
 - A. Indoor ambient temperature is greater than 75°F (24°C).
 - B. Coil temperature is equal to or greater than 104°F (40°C).

The indoor fan will run at low-speed for one to two minutes. If during that time the coil temperature rises above 106°F (42°C) the indoor fan will ramp to a pre-programmed heat speed for those conditions.
2. When the following conditions are meet:
 - A. Indoor ambient temperature is equal to or less than 75°F (24°C)
 - B. Coil temperature is equal to or greater than 106°F (42°C)

The indoor fan will run at low-speed, and within one minute, the indoor fan will ramp to a preprogrammed heat speed for those conditions.

SYSTEM PROTECTION FEATURES

These systems have several system protection features which are address in this section.. These features are:

- * Compressor protection
- * Indoor coil freeze protection
- * Intelligent Power Module
- * Power factor correction
- * Compressor over-current
- * Compressor over-load
- * System over-load

COMPRESSOR PROTECTION

In order to protect the compressor, there is a 3-minute delay after the unit shuts off. The delay occurs even during a call for heating or cooling.

INDOOR COIL FREEZE PROTECTION

When the unit is running in the COOL or DEHUMIDIFICATION mode, the indoor coil can freeze due to any of the following:

- * Low system charge
- * Reduced indoor airflow (restricted filter)
- * Restricted refrigerant flow
- * Low ambient temperature (outdoor)
- * Low indoor system load

The indoor coil temperature sensor monitors the coil temperature continuously.

- * If indoor coil temperature is less than 35.6°F (2°C) the compressor will operate at a reduce speed.
- * If the indoor coil temperature is less than 30.2°F (-1°C) for a duration of three (3) minutes, the compressor will stop. After an additional 30 second delay, the outdoor fan will stop. If the unit was initially in cooling mode, the indoor fan and louver operation will remain in its original state.
- * If indoor coil temperature rises above 42.8°F (6°C) and the compressor anti-short cycle duration of 3 minutes has been met, the system will return it its original state.

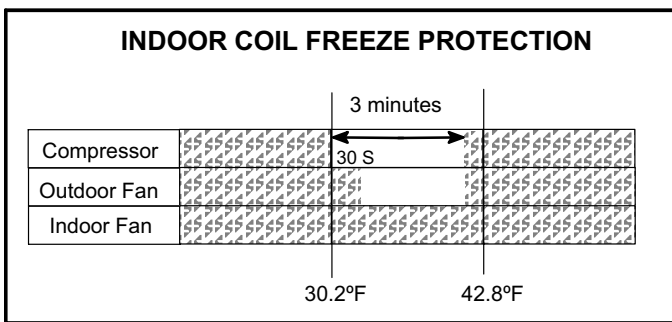

FIGURE 59

INTELLIGENT POWER MODULE (IPM) PROTECTION

The IPM module which is an integrated part of the outdoor control protects the system from the following conditions:

- * Inverter module overheating
- * High ambient temperatures
- * Low voltage

An inverter drive (VFD) works by taking AC mains (single or three phase) and first rectifying it into DC. The DC is usually smoothed with capacitors and often a DC choke before it is connected to a network of power transistors to turn it into three phases for the motor.

The network of power transistors of a small Inverter drive is actually one intelligent power module or inverter power module (IPM) and includes its own basic control circuits and protection from overheating and low voltage conditions.

The IPM inverts the DC into AC, hence the term *inverter*. The control method is known as for pulse width modulation (PWM). This means the DC is switched on and off very quickly (chopped) by the transistor switches.

POWER FACTOR CORRECTION (PFC) PROTECTION

The PFC module which is an integrated part of the outdoor control will monitor the DC bus for high, low and abnormal voltage conditions. If any of these conditions are detected the PFC function and compressor will stopped. The appropriate error code will be displayed on the indoor or outdoor units or both. Once the detected condition is corrected, the system will resume normal operations after the minimum 3-minute compressor delay is met. In the case of either an abnormal condition or a high / low voltage condition that has occurred three consecutive times, the system will need to be manually powered off (outdoor unit disconnect or main breaker panel) and back on to continue operation.

NOTE — HC for example is an error code for a PFC module failure. Codes that are generated by the PFC module when monitor voltage conditions are for example H4, U3, PL, etc.

COMPRESSOR OVER-CURRENT PROTECTION

The compressor current is continuously monitored. Base on the current draw (amps) the microprocessor will signal the compressor to increase, maintain drop or cycle **OFF** the compressor. Over current condition can result from any of the following:

- * High outdoor ambient temperatures
- * Locked rotor on the compressor
- * Outdoor air restriction or blockage
- * Restriction or blockage in refrigeration system

COMPRESSOR OVER-LOAD PROTECTION (CT1, 2 OR OVC-COM) (HIGH TEMPERATURE)

If temperature detected by the overload sensor exceeds 239°F (115°C), the compressor will stop. The outdoor fan will stop after a delay of 30 seconds. Once the compressor temperature drops below 204°F (95°C), the compressor overload protection feature will reset and the system will resume normal operations.

COMMUNICATION FAULT

If either the indoor or outdoor controls are unable to communicate with each other for a minimum of three minutes, the system will stop and an error code is displayed on the indoor unit.

OUTDOOR UNIT CONTROL PROTECTION

When excessive temperature is sensed at the outdoor unit control, the compressor will stop. The compressor anti-short cycle routine will be implemented and the compressor will not resume operation until the 3-minute time period has ended.

TEMPERATURE SENSORS — LOCATION, FUNCTION AND TROUBLESHOOTING

INDOOR UNIT

1. **Indoor Air Temperature Sensor (RT1):** This sensor measures the return air temperature coming into the indoor coil and sends this information to the indoor and outdoor controls.
2. **Indoor Coil Temperature Sensor (RT2):** This sensor is located on one of the copper tubes of the indoor coil. This sensor is used to:
 - A. Control the electronic expansion valve (EEV) in cooling mode;
 - B. Prevent freezing. During cooling operation, if the temperature drops abnormally, the compressor speed is decreased. If the temperature continues to fall, the compressor will be cycled OFF;

OUTDOOR UNIT

1. **Outdoor Coil Temperature Sensor (RT3):** This sensor is located on one of the copper tubes of the outdoor coil. This sensor is used to:
 - A. Control the electronic expansion valve (EEV) in heating mode;
 - B. Protect the system from high temperatures during cooling mode;
 - C. Terminate defrost cycle.
2. **Outdoor Air Temperature Sensor (RT4):** This sensor measures the outdoor air temperature coming into the outdoor coil and sends this information to the outdoor controls.
3. **Discharge Line Temperature Sensor (RT5):** This sensor is used to monitor the discharge line temperature. If the temperature of the discharge pipe rises abnormally, the compressor speed is decreased. If the temperature continues to rise, the compressor will be cycled OFF.

SYSTEM OVERLOAD PROTECTION

The system temperature protection feature is active under both cooling and heating modes.

Temperature sensors located on the indoor and outdoor coils and discharge line are constantly monitoring temperature conditions. If the system temperature protection feature detects a condition which requires compressor shut down, the compressor anti-short cycle routine will be implemented and the compressor will not resume operation until the 3-minute time delay has ended.

The following tables list conditions and responses by the system protection feature.

**TABLE 11
MONITORING OF INDOOR COIL (RT2) DURING HEATING MODE AND OUTDOOR COIL (RT3) DURING COOLING MODE**

Indoor Coil (RT2) during Heating	Outdoor Coil (RT3) during Cooling	Action
If indoor coil temperature is less than 126°F (52°C)	If outdoor coil temperature is less than 126°F (52°C)	Unit operations will return to original programmed operation.
If indoor coil temperature is greater than 131°F (55°C)	If outdoor coil temperature is greater than 131°F (55°C)	Change in compressor speed is not allowed.
If indoor coil temperature is greater than 136°F (58°C)	If outdoor coil temperature is greater than 136°F (58°C)	Compressor will run at reduced speed.
If indoor coil temperature is greater than 144°F (62°C)	If outdoor coil temperature is greater than 144°F (62°C)	Compressor will stop and the indoor fan will run at a preset speed.

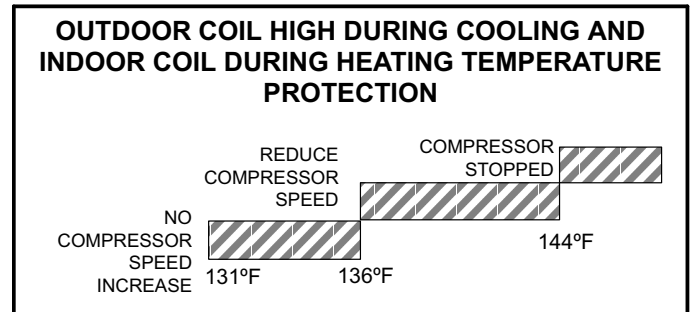

FIGURE 60

Discharge Line Temperature Sensor

High compressor discharge temperature can result from either of the following conditions:

- * Low refrigerant charge
- * Restricted refrigerant flow

The compressor discharge line temperature sensor continuously monitors the temperature and sends that data to the outdoor control. If the discharge line temperature exceeds its maximum operating temperature, the compressor will be shut down (table12).

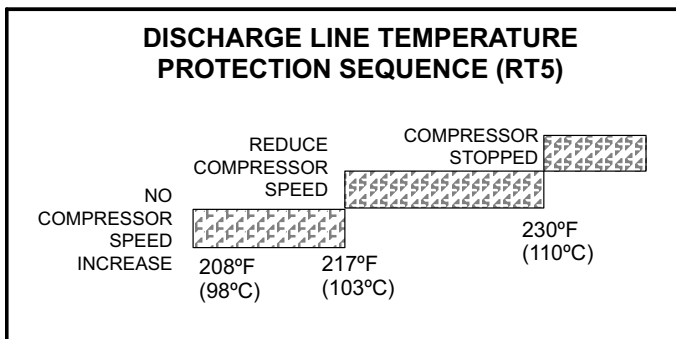

FIGURE 61

**TABLE 12
MONITORING OF OUTDOOR DISCHARGE (RT5) LINE TEMPERATURE**

Condition	Action
If outdoor discharge line temperature is greater than 208°F (98°C)	Change in compressor speed is not allowed.
If outdoor discharge line temperature is greater than 217°F (103°C)	Compressor will run at reduced speed.
If outdoor discharge line temperature is greater than 230°F (110°C)	Compressor will stop.
If outdoor discharge line temperature is less than 194°F (90°C)	After anti-short cycle (3 minutes) delay, the compressor and outdoor fan will resume operation.

TEMPERATURE SENSOR FAULTS

Refer to the error code tables for details concerning fault conditions and equipment behavior.

TESTING TEMPERATURE SENSOR RESISTANCES

Sensors are connected to the indoor and outdoor controls through field-replaceable harnesses. These sensors provide indoor ambient air (RT1), outdoor ambient air (RT4), indoor coil (RT2), outdoor coil (RT3) and outdoor discharge line (RT5) temperatures to the indoor and outdoor controls to identify fault conditions. As the temperature changes, the resistance across these sensor changes. Tables 13 through 15 indicates how the resistance varies as the temperature changes for all reference temperature sensors.

TABLE 13
INDOOR AND OUTDOOR AMBIENT SENSOR RESISTANCE VALUES (15K) — °F (°C)

Temp.(°F)	Resistance(kΩ)	Temp.(°F)	Resistance(kΩ)	Temp.(°F)	Resistance(kΩ)	Temp.(°F)	Resistance(kΩ)
-2.2	138.1	68	18.75	138.2	3.848	208.4	1.071
-0.4	128.6	69.8	17.93	140	3.711	210.2	1.039
1.4	121.6	71.6	17.14	141.8	3.579	212	1.009
3.2	115	73.4	16.39	143.6	3.454	213.8	0.98
5	108.7	75.2	15.68	145.4	3.333	215.6	0.952
6.8	102.9	77	15	147.2	3.217	217.4	0.925
8.6	97.4	78.8	14.36	149	3.105	219.2	0.898
10.4	92.22	80.6	13.74	150.8	2.998	221	0.873
12.2	87.35	82.4	13.16	152.6	2.896	222.8	0.848
14	82.75	84.2	12.6	154.4	2.797	224.6	0.825
15.8	78.43	86	12.07	156.2	2.702	226.4	0.802
17.6	74.35	87.8	11.57	158	2.611	228.2	0.779
19.4	70.5	89.6	11.09	159.8	2.523	230	0.758
21.2	66.88	91.4	10.63	161.6	2.439	231.8	0.737
23	63.46	93.2	10.2	163.4	2.358	233.6	0.717
24.8	60.23	95	9.779	165.2	2.28	235.4	0.697
26.6	57.18	96.8	9.382	167	2.206	237.2	0.678
28.4	54.31	98.6	9.003	168.8	2.133	239	0.66
30.2	51.59	100.4	8.642	170.6	2.064	240.8	0.642
32	49.02	102.2	8.297	172.4	1.997	242.6	0.625
33.8	46.6	104	7.967	174.2	1.933	244.4	0.608
35.6	44.31	105.8	7.653	176	1.871	246.2	0.592
37.4	42.14	107.6	7.352	177.8	1.811	248	0.577
39.2	40.09	109.4	7.065	179.6	1.754	249.8	0.561
41	38.15	111.2	6.791	181.4	1.699	251.6	0.547
42.8	36.32	113	6.529	183.2	1.645	253.4	0.532
44.6	34.58	114.8	6.278	185	1.594	255.2	0.519
46.4	32.94	116.6	6.038	186.8	1.544	257	0.505
48.2	31.38	118.4	5.809	188.6	1.497	258.8	0.492
50	29.9	120.2	5.589	190.4	1.451	260.6	0.48
51.8	28.51	122	5.379	192.2	1.408	262.4	0.467
53.6	27.18	123.8	5.197	194	1.363	264.2	0.456
55.4	25.92	125.6	4.986	195.8	1.322	266	0.444
57.2	24.73	127.4	4.802	197.6	1.282	267.8	0.433
59	23.6	129.2	4.625	199.4	1.244	269.6	0.422
60.8	22.53	131	4.456	201.2	1.207	271.4	0.412
62.6	21.51	132.8	4.294	203	1.171	273.2	0.401
64.4	20.54	134.6	4.139	204.8	1.136	275	0.391
66.2	19.63	136.4	3.99	206.6	1.103	276.8	0.382

TABLE 14
INDOOR AND OUTDOOR COIL SENSOR RESISTANCE VALUES (20K) — °F (°C)

Appendix 2: Resistance Table of Outdoor and Indoor Tube Temperature Sensors(20K)

Temp.(°F)	Resistance(kΩ)	Temp.(°F)	Resistance(kΩ)	Temp.(°F)	Resistance(kΩ)	Temp.(°F)	Resistance(kΩ)
-2.2	181.4	68	25.01	138.2	5.13	208.4	1.427
-0.4	171.4	69.8	23.9	140	4.948	210.2	1.386
1.4	162.1	71.6	22.85	141.8	4.773	212	1.346
3.2	153.3	73.4	21.85	143.6	4.605	213.8	1.307
5	145	75.2	20.9	145.4	4.443	215.6	1.269
6.8	137.2	77	20	147.2	4.289	217.4	1.233
8.6	129.9	78.8	19.14	149	4.14	219.2	1.198
10.4	123	80.6	18.13	150.8	3.998	221	1.164
12.2	116.5	82.4	17.55	152.6	3.861	222.8	1.131
14	110.3	84.2	16.8	154.4	3.729	224.6	1.099
15.8	104.6	86	16.1	156.2	3.603	226.4	1.069
17.6	99.13	87.8	15.43	158	3.481	228.2	1.039
19.4	94	89.6	14.79	159.8	3.364	230	1.01
21.2	89.17	91.4	14.18	161.6	3.252	231.8	0.983
23	84.61	93.2	13.59	163.4	3.144	233.6	0.956
24.8	80.31	95	13.04	165.2	3.04	235.4	0.93
26.6	76.24	96.8	12.51	167	2.94	237.2	0.904
28.4	72.41	98.6	12	168.8	2.844	239	0.88
30.2	68.79	100.4	11.52	170.6	2.752	240.8	0.856
32	65.37	102.2	11.06	172.4	2.663	242.6	0.833
33.8	62.13	104	10.62	174.2	2.577	244.4	0.811
35.6	59.08	105.8	10.2	176	2.495	246.2	0.77
37.4	56.19	107.6	9.803	177.8	2.415	248	0.769
39.2	53.46	109.4	9.42	179.6	2.339	249.8	0.746
41	50.87	111.2	9.054	181.4	2.265	251.6	0.729
42.8	48.42	113	8.705	183.2	2.194	253.4	0.71
44.6	46.11	114.8	8.37	185	2.125	255.2	0.692
46.4	43.92	116.6	8.051	186.8	2.059	257	0.674
48.2	41.84	118.4	7.745	188.6	1.996	258.8	0.658
50	39.87	120.2	7.453	190.4	1.934	260.6	0.64
51.8	38.01	122	7.173	192.2	1.875	262.4	0.623
53.6	36.24	123.8	6.905	194	1.818	264.2	0.607
55.4	34.57	125.6	6.648	195.8	1.736	266	0.592
57.2	32.98	127.4	6.403	197.6	1.71	267.8	0.577
59	31.47	129.2	6.167	199.4	1.658	269.6	0.563
60.8	30.04	131	5.942	201.2	1.609	271.4	0.549
62.6	28.68	132.8	5.726	203	1.561	273.2	0.535
64.4	27.39	134.6	5.519	204.8	1.515	275	0.521
66.2	26.17	136.4	5.32	206.6	1.47	276.8	0.509

**TABLE 15
OUTDOOR DISCHARGE LINE SENSOR RESISTANCE VALUES (50K) — °F (°C)**

Temp.(°F)	Resistance(kΩ)	Temp.(°F)	Resistance(kΩ)	Temp.(°F)	Resistance(kΩ)	Temp.(°F)	Resistance(kΩ)
-20.2	853.5	50	98	120.2	18.34	190.4	4.754
-18.4	799.8	51.8	93.42	122	17.65	192.2	4.609
-16.6	750	53.6	89.07	123.8	16.99	194	4.469
-14.8	703.8	55.4	84.95	125.6	16.36	195.8	4.334
-13	660.8	57.2	81.05	127.4	15.75	197.6	4.204
-11.2	620.8	59	77.35	129.2	15.17	199.4	4.079
-9.4	580.6	60.8	73.83	131	14.62	201.2	3.958
-7.6	548.9	62.6	70.5	132.8	14.09	203	3.841
-5.8	516.6	64.4	67.34	134.6	13.58	204.8	3.728
-4	486.5	66.2	64.33	136.4	13.09	206.6	3.619
-2.2	458.3	68	61.48	138.2	12.62	208.4	3.514
-0.4	432	69.8	58.77	140	12.17	210.2	3.413
1.4	407.4	71.6	56.19	141.8	11.74	212	3.315
3.2	384.5	73.4	53.74	143.6	11.32	213.8	3.22
5	362.9	75.2	51.41	145.4	10.93	215.6	3.129
6.8	342.8	77	49.19	147.2	10.54	217.4	3.04
8.6	323.9	78.8	47.08	149	10.18	219.2	2.955
10.4	306.2	80.6	45.07	150.8	9.827	221	2.872
12.2	289.6	82.4	43.16	152.6	9.489	222.8	2.792
14	274	84.2	41.34	154.4	9.165	224.6	2.715
15.8	259.3	86	39.61	156.2	8.854	226.4	2.64
17.6	245.6	87.8	37.96	158	8.555	228.2	2.568
19.4	232.6	89.6	36.38	159.8	8.268	230	2.498
21.2	220.5	91.4	34.88	161.6	7.991	231.8	2.431
23	209	93.2	33.45	163.4	7.726	233.6	2.365
24.8	198.3	95	32.09	165.2	7.47	235.4	2.302
26.6	199.1	96.8	30.79	167	7.224	237.2	2.241
28.4	178.5	98.6	29.54	168.8	6.998	239	2.182
30.2	169.5	100.4	28.36	170.6	6.761	240.8	2.124
32	161	102.2	27.23	172.4	6.542	242.6	2.069
33.8	153	104	26.15	174.2	6.331	244.4	2.015
35.6	145.4	105.8	25.11	176	6.129	246.2	1.963
37.4	138.3	107.6	24.13	177.8	5.933	248	1.912
39.2	131.5	109.4	23.19	179.6	5.746	249.8	1.863
41	125.1	111.2	22.29	181.4	5.565	251.6	1.816
42.8	119.1	113	21.43	183.2	5.39	253.4	1.77
44.6	113.4	114.8	20.6	185	5.222	255.2	1.725
46.4	108	116.6	19.81	186.8	5.06	257	1.682
48.2	102.8	118.4	19.06	188.6	4.904	258.8	1.64

SYSTEM TEMPERATURE SENSORS

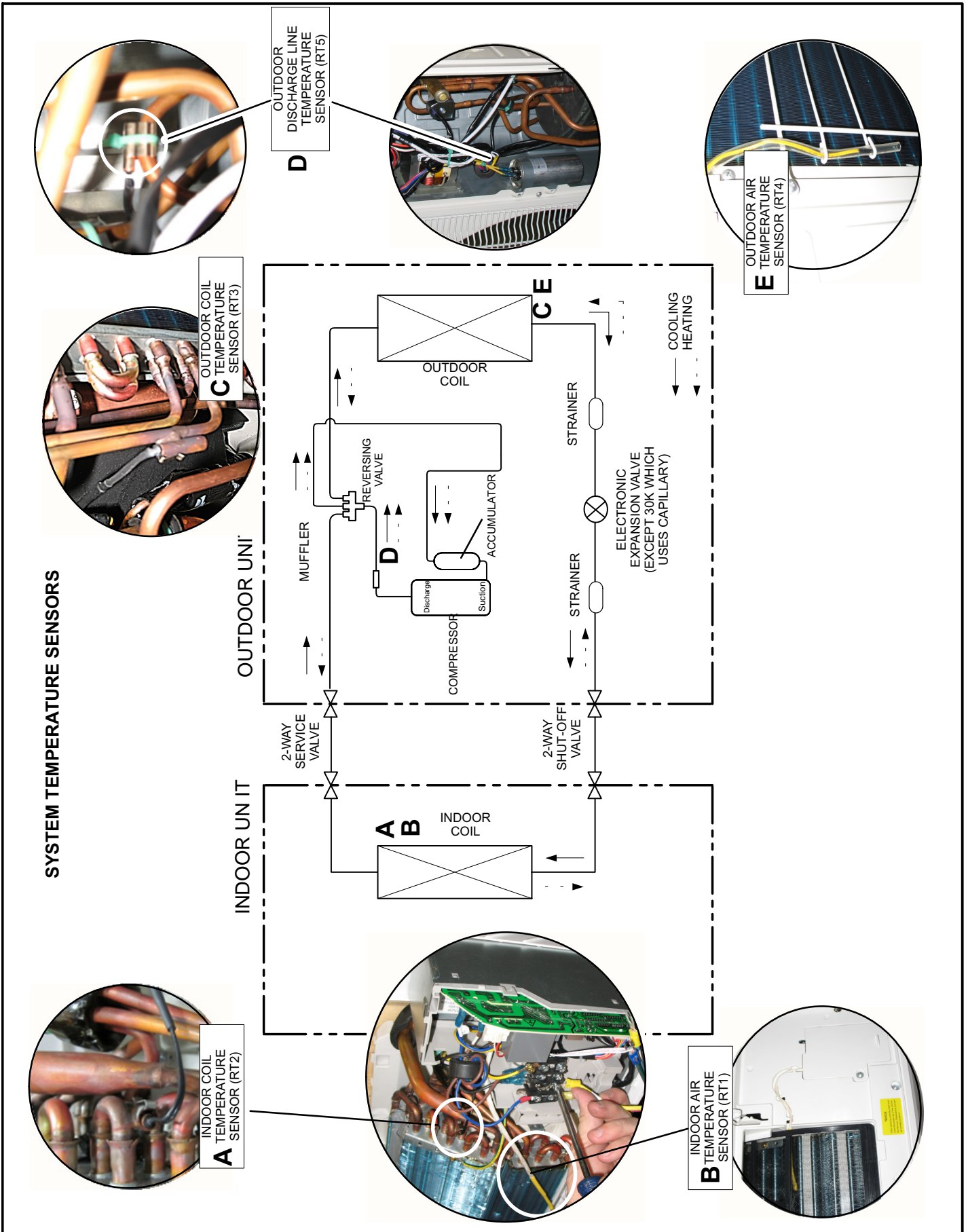

FIGURE 62

OPTIMAL SYSTEM OPERATING RANGES

If system is operated outside of its optimal operating range, either of the following actions may occur:

- * A system safety device may cause the system to stop operating.
- * Indoor unit may experience excessive condensation and cause leakage.

IMPORTANT NOTES:

- * The outdoor unit operating ranges are listed in figures 63 and 64.
- * If the system is in temperatures outside of these ranges, design functions in the outdoor control may reduce, terminate or prevent system operation

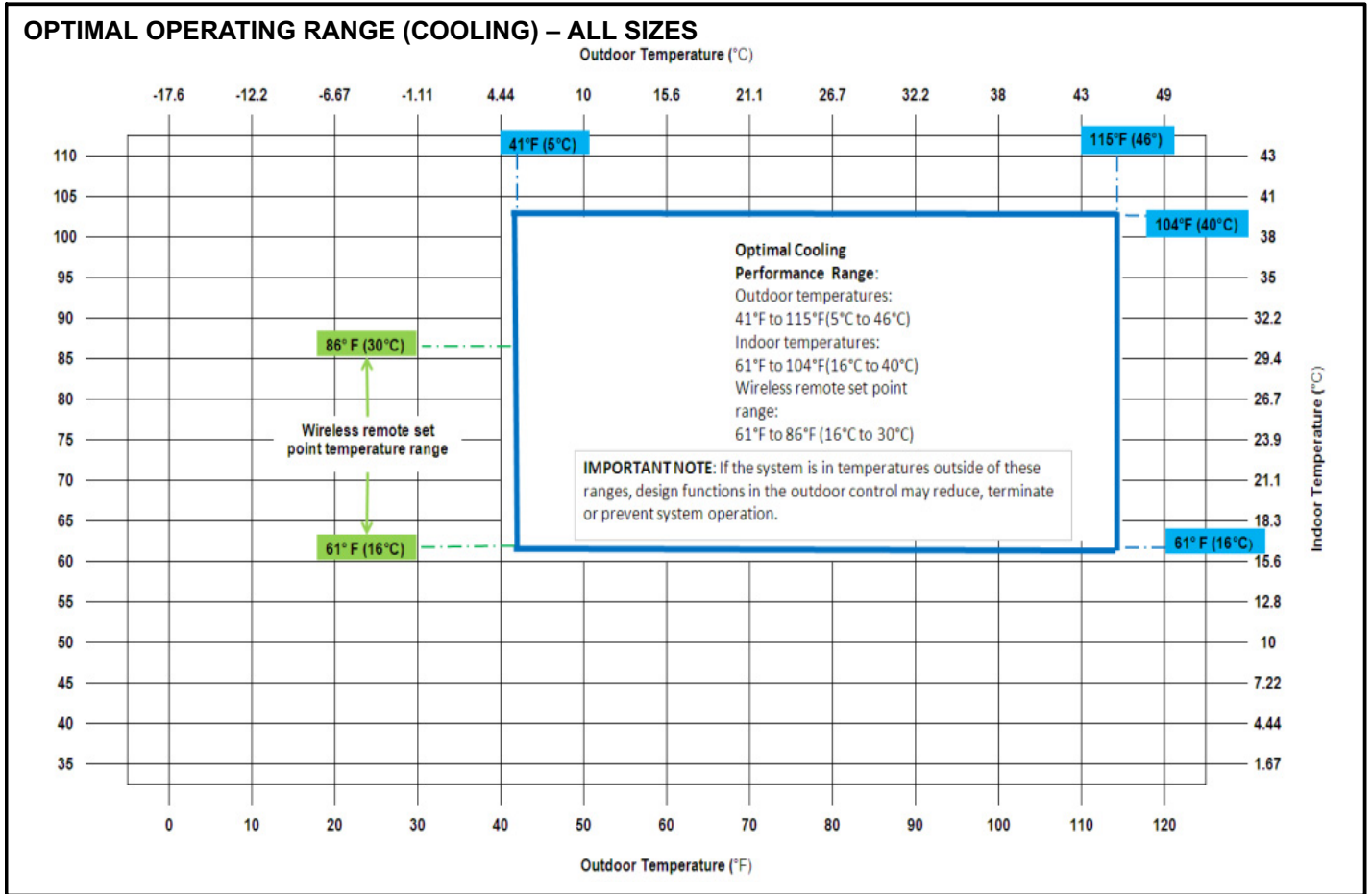

FIGURE 63

OPTIMAL OPERATING RANGE (HEATING) – ALL SIZES

Outdoor Temperature (°C)

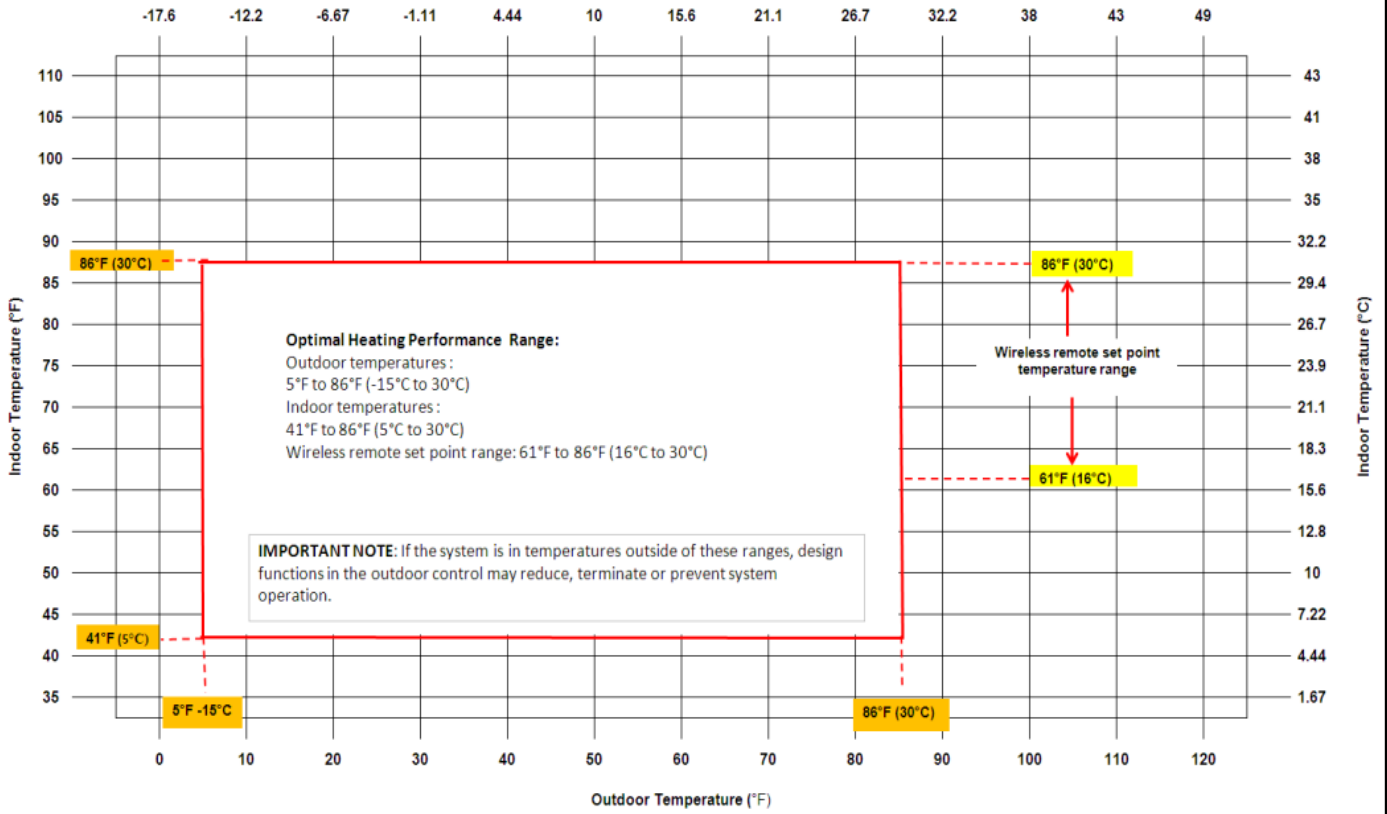

FIGURE 64

TYPICAL 9-12 KBTU INDOOR UNIT CONTROL (115V)

Checking Indoor Control

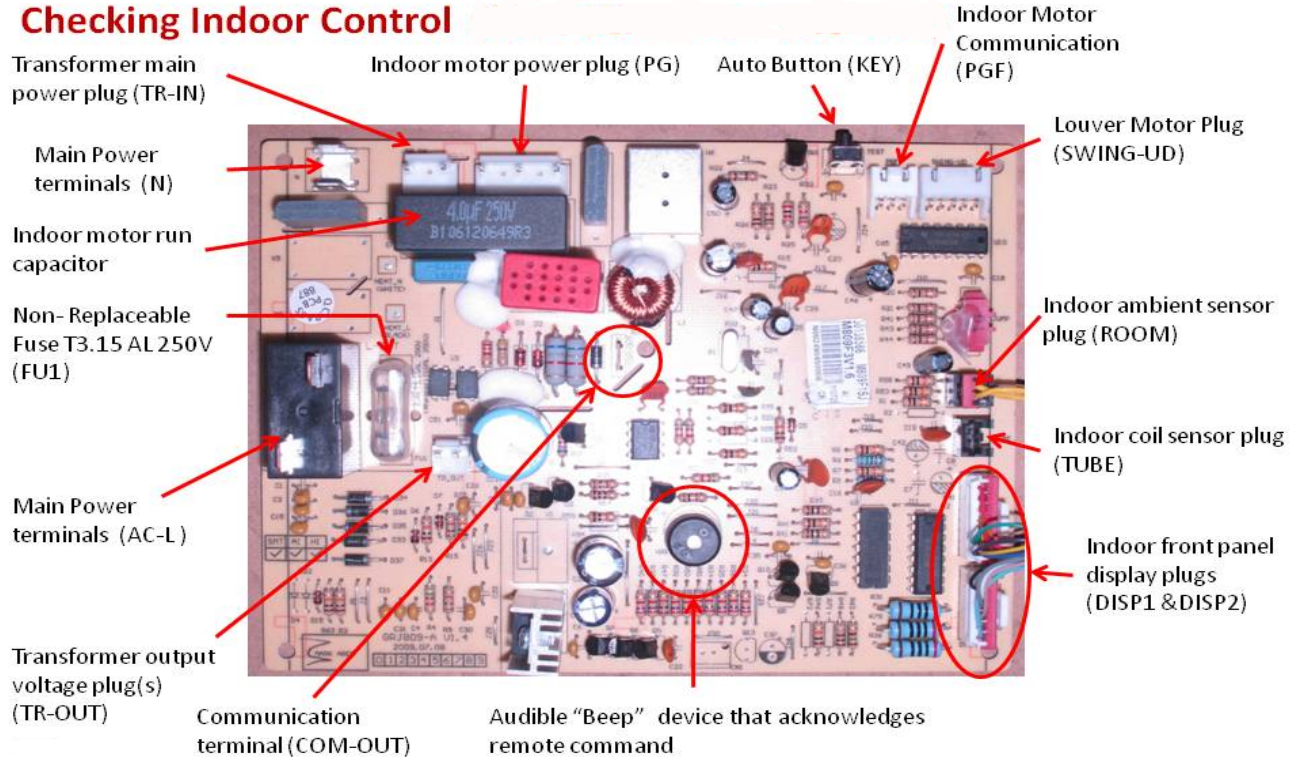

FIGURE 65

TYPICAL 9-12 KBTU OUTDOOR CONTROLS (115V)

Checking Outdoor Control

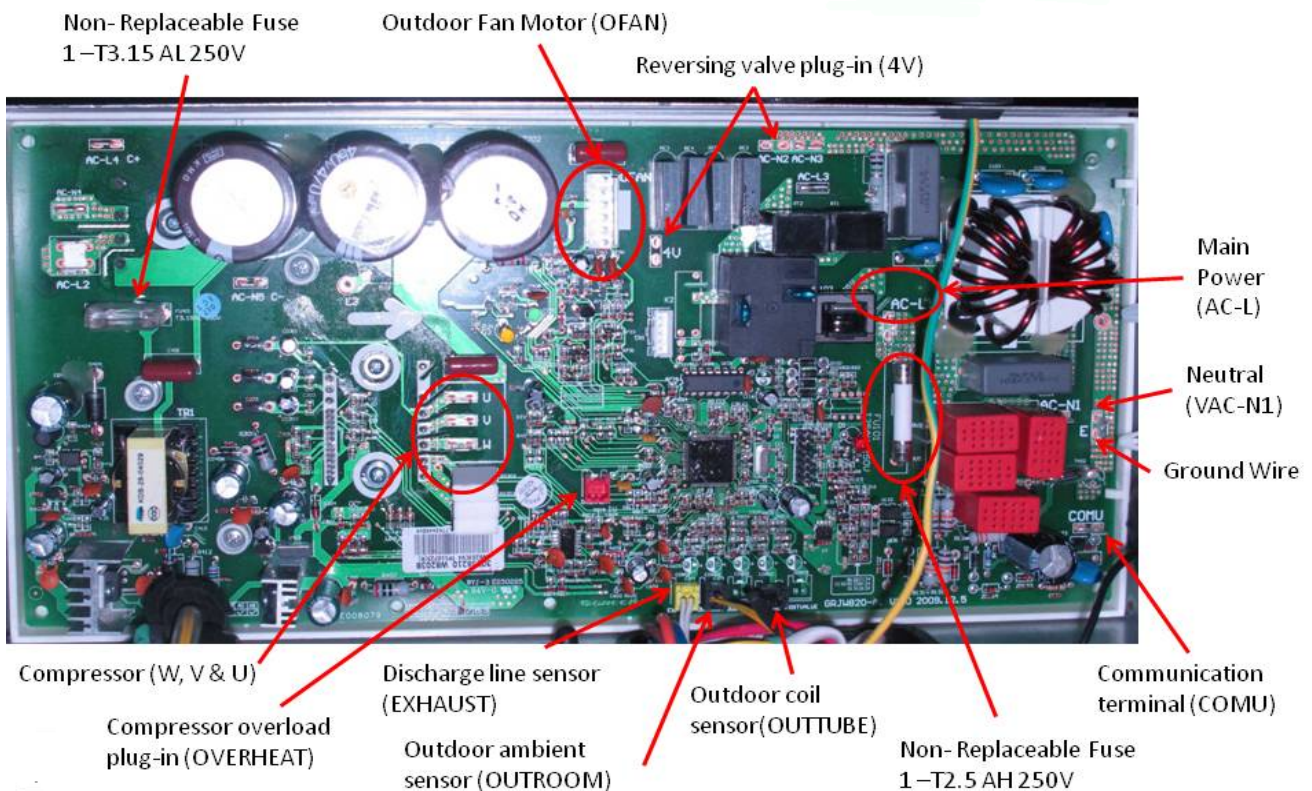

FIGURE 66

TYPICAL 9-12 KBTU OUTDOOR UNIT CONTROL SYSTEM STATUS AND ERROR LED LOCATIONS

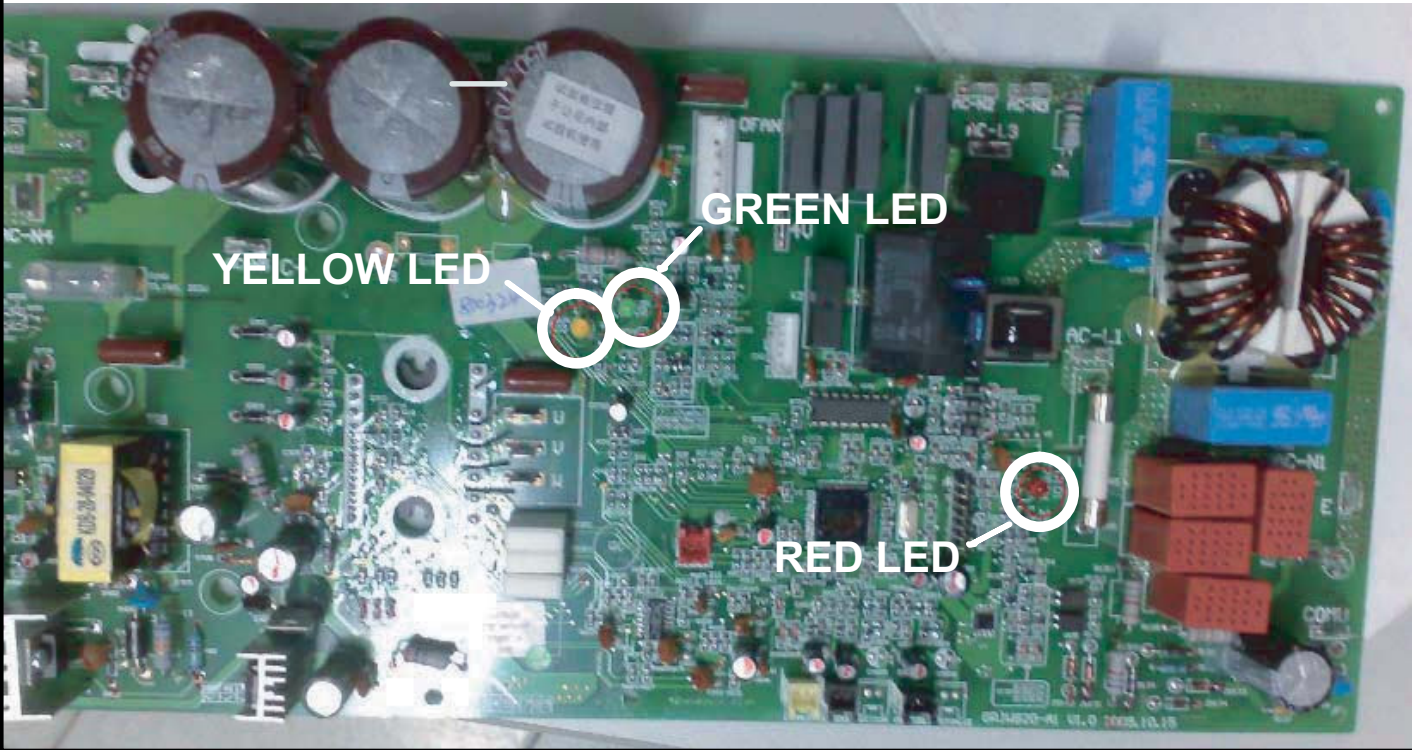

FIGURE 67

Indoor and Outdoor Error Codes

This section identifies error codes that appear on the front panel of the indoor unit or outdoor unit control. Many of the error codes will automatically clear themselves when the error no longer exist. However some error codes may required disconnecting power to the system at the unit disconnect switch or circuit breaker in order to clear them and resuming system operations.

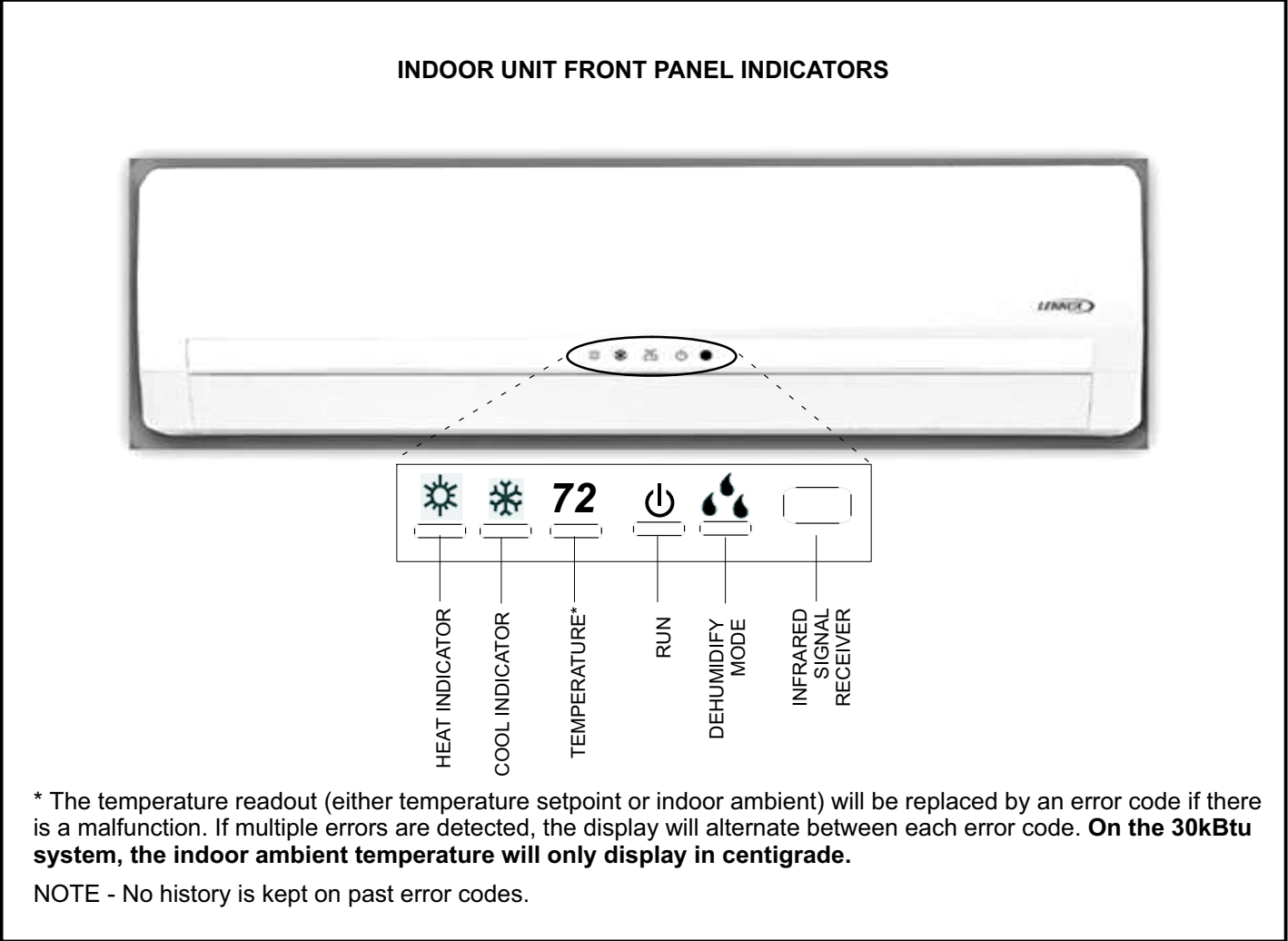

FIGURE 68

**TABLE 16
INDOOR UNIT DISPLAY CODES (ALL SYSTEMS)**

Indoor Character Display	Error Description	System Status	Troubleshooting for Possible Causes
b5	RT1 room temperature sensor malfunction	Cooling and dehumidification modes will continue to operate as well as indoor fan. Unit will not operate in heating mode.	<ul style="list-style-type: none"> • Check sensor to ensure that it is in acceptable range. • Check sensor for proper resistance. • Replace sensor if shorted, open or out-of-calibration.
b7	RT2 coil temperature sensor malfunction		
C5	Indoor control jumper is missing (labeled JUMP)	All system functions are terminated.	<ul style="list-style-type: none"> • Check indoor control jumper connections and replace jumper, if missing.
dd	Pre-operation function	When unit is set to cooling mode and setpoint is 86°F (30°C), press the remote - and + button in the following sequence (- + - + - +) for three seconds to place the unit in pre-operation mode. This cooling operation with the indoor fan off and dd is displayed on indoor unit.	Normal system operation
dn	Pre-operation function error	If during pre-operation mode, if it is determine that the unit is wired incorrectly or the expansion valve has malfunction this code will display.	<ul style="list-style-type: none"> • Check expansion valve • Check wiring.
EE	Intelligent Power Module protection limit	System will continue to run; however at reduced compressor speed until issue is corrected.	<ul style="list-style-type: none"> • Replace outdoor control.
EU	Intelligent Power Module protection limit	All system functions are terminated.	<p>Intelligent Power Module protection limit error can result from any of the following:</p> <ul style="list-style-type: none"> • Loss of cooling to the heat sink • Low voltage • High ambient temperature • Loose screws fastening the outdoor control to the heat sink <p>Check all and correct, if necessary. See figure 92 for troubleshooting.</p>
E1	System high pressure	All system functions are terminated except indoor fan..	Outdoor unit high pressure switch is disconnected or has malfunctioned. Verify connection to outdoor control. If connection is verified and system is still displaying E1, replace high pressure sensor.
E2	Indoor coil freeze protection	All system functions are terminated except indoor fan. The indoor coil sensor (RT2) monitors the coil temperature continuously. If coil temperature drops below 30.2°F (-1°C), the compressor and the outdoor fan (30 seconds later) are switched off. Condition is cleared when indoor coil temperature rises above 42.8°F (6°C) and the compressor has been off for a minimum of three minutes.	<ul style="list-style-type: none"> • Check for restricted indoor airflow and change filter, if necessary. • Check for restricted refrigerant flow. • Check for low outdoor ambient temperature or low indoor system load.
E3	Low pressure protection	All system functions are terminated except indoor fan.	<ul style="list-style-type: none"> • Check for proper clearances around outdoor unit. • Check outdoor coil for and clean, if necessary.
E4	Discharge line temperature protection	Sensor RT5 monitors compressor discharge line temperature and communicates with outdoor unit microprocessor. Depending on the temperature measured, the compressor speed will be increased to meet the load or will continue to run at the existing speed. If the temperature becomes excessively high, the compressor will be de-energized. When the compressor discharge temperature drops below 194°F (90°C), the unit will resume normal operation.	<ul style="list-style-type: none"> • Check for low refrigerant charge. • Check for restricted refrigerant flow due to blocked capillary.
E5	Compressor over-current protection	All system functions are terminated except indoor fan.	<ul style="list-style-type: none"> • Check for locked compressor rotor due to excessively high ambient temperature. • Check for restricted refrigerant flow due to blocked capillary tubing. • Check outdoor unit to make sure that coil is not blocked.
E6	Communication failure between indoor unit and outdoor unit		<ul style="list-style-type: none"> • If error is displayed on outdoor unit, check communications cable / wire at indoor and outdoor controls to verify proper connection.

Continued — Indoor Display Codes (All Systems)

Indoor Character Display	Error Description	System Status	Troubleshooting for Possible Causes
E7	Mode conflict	If the outdoor unit for example is operating in heating mode based on demand from a indoor unit and there is a call for cooling at one of the other indoor zone unit. The indoor unit will display E7.	Normal system operation
E8	Compressor high temperature protection	All system functions are terminated after three-minute delay except indoor fan.	See figure 95.
FA	Over tube temperature drop frequency	Elevated temperature sensors readings will adjust compressor frequency. Specific temperature sensor values will reduce compressor frequency.	<ul style="list-style-type: none"> • Check for locked compressor rotor due to excessively high ambient temperature. • Check for restricted refrigerant flow due to blocked capillary tubing. • Check outdoor unit to make sure that coil is not blocked.
FC	Door malfunction	Access door malfunction	Only floor standing units. Unit will cycled OFF.
FE	Compressor overload sensor malfunction	Compressor overload sensor issue (Open contacts). Unit will cycled OFF.	<ul style="list-style-type: none"> • Check for locked compressor rotor due to excessively high ambient temperature. • Check for restricted refrigerant flow due to blocked capillary tubing. • Check outdoor unit to make sure that coil is not blocked.
FH	Anti-freezing upper and lower limit range	Compressor will run at reduced speed until temperature increases.	Wait for temperature to increase above 42.8°F (6°C), then recheck operation status.
F0	Indoor coil is gathering refrigerant	All system functions are terminated except indoor fan.	<ul style="list-style-type: none"> • Pump refrigerant into outdoor unit. Check 2-way shut-off valve in small line to see if it is closed or if flow is restricted. Correct, if necessary.
F1	Indoor ambient sensor (RT1) open or short circuited	Cooling and dehumidification modes will continue to operate as well as indoor fan. Unit will not operate in heating mode.	<ul style="list-style-type: none"> • Check sensor to ensure that it is in acceptable range. • Check sensor for proper resistance. • Replace sensor if shorted, open or out-of-calibration.
F2	Indoor coil sensor (RT2) open or short circuited		
F3	Outdoor ambient sensor (RT4) open or short circuit	All system functions are terminated except indoor fan.	<ul style="list-style-type: none"> • Check sensor to ensure that it is in acceptable range. • Check sensor for proper resistance. • Replace sensor if shorted, open or out-of-calibration.
F4	Outdoor coil sensor (RT3) open or short circuit		
F5	Discharge line sensor (RT5) error	All system functions will continue to run for 3 minutes, then terminate. Indoor fan will continue to run.	<ul style="list-style-type: none"> • Check sensor for proper resistance. Sensor should be in acceptable range. Replace sensor if shorted, open or out-of-calibration.
F6	Compressor overload limit issue	Normal operational state with compressor speed automatically adjust for operational conditions. System will continue to operation at reduced compressor speed until issue is corrected.	<ul style="list-style-type: none"> • Check outdoor ambient air temperature. Could be too high. • Check for locked compressor rotor. • Check for blocked refrigeration circuit (capillary tubes for example). • Check for blocked or restricted outdoor air flow. Clear, if necessary. • Check for low refrigerant charge.
F8	High current limit issue	System will continue to operate at reduce compressor speed until issue is corrected.	<ul style="list-style-type: none"> • Check for low or high input voltage. Correct if necessary. Could be too high.
F9	Discharge line temperature too high		<ul style="list-style-type: none"> • Check discharge line temperature. Correct if to high.
HC	Power factor correction protection		<ul style="list-style-type: none"> • See troubleshooting section.
HE	Compressor demagnetization protection	Compressor has exceeded peak demagnetization current (41A), reduced frequency. Compressor running at reduced frequency.	De-energize system and restart.
H0	Heating mode anti-high temperature protection		See figure 97.
H1	Defrosting (heat pump only)	Normal operation	Normal defrost operation.
H2	Electrostatic protection	System protection feature. All system functions are terminated except indoor fan.	Excessive electrostatic charge present. Correct, if possible.

Continued — Indoor Display Codes (All Systems)

Indoor Character Display	Error Description	System Status	Troubleshooting for Possible Causes
H3	Compressor overload protection sensor (CT1,2) malfunction.	All system functions are terminated except indoor fan.	<ul style="list-style-type: none"> • Check for proper wiring connections and loose wires at outdoor control (CT1, 2) input plug. • Check for continuity across overload protection sensor terminals mounted at top of compressor.
H4	Compressor high temperature protection	All system functions are terminated except indoor fan.	<ul style="list-style-type: none"> • Check for proper wiring connections and loose wires at outdoor control (CT1, 2) input plug. • Check for continuity across overload protection sensor terminals mounted at top of compressor.
H5	Intelligent Power Module (IPM) module protection		<p>This can be caused by any of the following:</p> <ul style="list-style-type: none"> • Loss of cooling to the heat sink • Low voltage. • High ambient temperature • Loose screws fastening the outdoor control to the heat sink
H6	Indoor fan not communicating	All system functions are terminated.	<p>Possible Indoor control failure or indoor motor failure.</p> <ul style="list-style-type: none"> • Check wiring between fan motor and indoor control. • Check wiring between fan motor and terminal marked OFFAN. • Replace one or both, if necessary.
H7	Compressor lost-step protection	If this condition is detected six times within one hour, system will shut down.	<p>The following conditions will generate this error:</p> <ul style="list-style-type: none"> • Unable to detect rotor position during operation • Actual rotor rotations exceed set speed <p>Outdoor unit must be de-energized and re-energized to resume normal operation.</p>
Lc	Unit start-up failure	All system functions are terminated.	See unit start-up troubleshooting charts.
Ld	Compressor loss of phase protection	Outdoor unit must be de-energized and re-energized to resume normal operation.	Compressor start up phase current is lower than 0.5 amps.
LE	Compressor locked rotary protection	Compressor unable to start.	De-energize system and restart.
LP	Indoor and outdoor unit mismatch	All system functions are terminated.	The two system components are mismatched. Refer to engineering handbook for correct match-up.
L3	Outdoor DC fan motor malfunction	All system functions are terminated.	<ul style="list-style-type: none"> • Check wiring between fan motor and outdoor control terminal marked OFFAN. • If wiring is correct, replace outdoor DC fan motor.
L9	Power factor protection	All system functions are terminated.	Indoor unit is experiencing either a high or low input voltage condition. Verify proper input voltage at terminal strip N(1) and 3 .
Pc	Current detect circuit malfunction or current sensor malfunction	Outdoor unit must be de-energized and re-energized to resume normal operation.	The offset voltage is higher than the limit value. If this condition is detected six times within one hour, system will shut down.

Continued — Indoor Display Codes (All Systems)

Indoor Character Display	Error Description	System Status	Troubleshooting for Possible Causes
PH	High voltage protection	All system functions are terminated.	<ul style="list-style-type: none"> • Check input voltage on outdoor unit terminal strip (N and L terminals). • If voltage is higher than 265VAC, disconnect power to unit. Correct input voltage problem before reapplying power to system. • If voltage is below 265VAC, then check capacitor while unit is turned off. • If voltage is some other value, replace capacitor. • If voltage is some other value, replace capacitor. • If input voltage and capacitor are normal, replace outdoor control.
PL	Low voltage protection		<ul style="list-style-type: none"> • Check input voltage on outdoor unit terminal strip (N and L terminals).
PU	Capacitor charge failure		See figure 97.
P5	Compressor overcurrent protection		
P6	Communication failure between main board and driver board	All system functions are terminated except indoor fan.	Communication bus will automatically reset and resume normal operation.
P7	Outdoor control failure	All system functions are terminated.	Replace outdoor control.
P8	Intelligent Power Module temperature is too high	All system functions are terminated except indoor fan.	<p>Intelligent Power Module high temperature error can result from any of the following:</p> <ul style="list-style-type: none"> • Loss of cooling to the heat sink • Low voltage • High ambient temperature • Loose screws fastening the outdoor control to the heat sink <p>Check all and correct, if necessary.</p>
U1	Compressor current test circuit malfunction	All system functions are terminated except indoor fan.	Replace outdoor control.
U2	Compressor protection against loss-of-phase	Unit will cycle off.	De-energize system and restart.
U3	Unstable DC voltage protection	All system functions are terminated except indoor fan.	Input voltage is not stable.
U4	Compressor reverse protection	Unit will cycle off.	De-energize system and restart.
U5	Entire unit current monitoring malfunction	All system functions are terminated except indoor fan.	<ul style="list-style-type: none"> • Outdoor control malfunction. • Check refrigerant charge. • Check for electric current error (low current amperage or overcurrent).
U7	Reversing valve malfunction	All system functions are terminated.	<ul style="list-style-type: none"> • Check input voltage on outdoor unit terminal strip (N and L terminals). If lower than 175 VAC, correct voltage problem. • Check reversing valve wiring connection for damage. • If voltage and wiring connections are correct, replace reversing valve.
U8	Disconnection of the exhaust temperature sensor	Unit will cycle off.	<ul style="list-style-type: none"> • Check for proper wiring connections and loose wires at outdoor control (CT1, 2) input plug. • Check for continuity across overload protection sensor terminals mounted at top of compressor.
U9	Outdoor unit zero cross detection error	All system functions are terminated except indoor fan.	Replace outdoor control.

**TABLE 17
9-12 KBTU SYSTEM STATUS AND ERROR CODES — OUTDOOR LEDS**

Outdoor LED Displays (number of blinks)			Description	System Status	
Yellow	Red	Green			
SYSTEM STATUS LEDS					
		BLINKING	Indoor and outdoor units are communicating	System is operating normally. The blinking interval is 1 second on, 1 second off.	
BLINKING			Compressor is running	System is operating normally. The blinking interval is 1 second on, 1 second off.	
	8		System has a heating or cooling demand	System is operating normally. The blinking interval is 1 second on, 1 second off and up to three second pause between repeating blinks.	
SYSTEM ERROR DISPLAY AND LEDS					
Outdoor LED Displays (number of blinks)			Error Description	System Status	Troubleshooting for Possible Causes
Yellow	Red	Green			
OFF	OFF	OFF	Communication failure between indoor unit and outdoor unit	All system functions are terminated after three-minute delay except indoor fan.	<ul style="list-style-type: none"> • If error is displayed on outdoor unit, check communications cable / wire at indoor and outdoor controls to verify proper connection. See figure 81.
OFF	OFF	OFF	Reversing valve malfunction	All system functions are terminated after three-minute delay except indoor fan.	<ul style="list-style-type: none"> • Check input voltage on outdoor unit terminal strip (N and L terminals). If lower than 175 VAC, correct voltage problem. • Check reversing valve wiring connection for damage. • If voltage and wiring connections are correct, replace reversing valve.
OFF	1	OFF	High current limit issue	System will continue to operate at reduce compressor speed until issue is corrected.	<ul style="list-style-type: none"> • Check for low or high input voltage. Correct if necessary. Could be too high.
OFF	2	OFF	Discharge line temperature too high		<ul style="list-style-type: none"> • Check discharge line temperature. Correct if to high.
OFF	3	OFF	Compressor overload limit issue	Normal operational state with compressor speed automatically adjust for operational conditions. System will continue to operation at reduced compressor speed until issue is corrected.	<ul style="list-style-type: none"> • Check outdoor ambient air temperature. Could be too high. • Check for locked compressor rotor. • Check for blocked refrigeration circuit (capillary tubes for example). • Check for blocked or restricted outdoor air flow. Clear, if necessary. • Check for low refrigerant charge.
OFF	4	OFF	Anti-freezing upper and lower limit range	Compressor will run at reduced speed until temperature increases.	<ul style="list-style-type: none"> • Wait for temperature to increase above 42.8°F (6°C), then recheck operation status.
OFF	5	OFF	Outdoor coil sensor (RT3) open or short circuit	All system functions are terminated except indoor fan.	<ul style="list-style-type: none"> • Check sensor to ensure that it is in acceptable range. • Check sensor for proper resistance. • Replace sensor if shorted, open or out-of-calibration.
OFF	6	OFF	Outdoor ambient sensor (RT4) open or short circuit	All system functions are terminated except indoor fan.	<ul style="list-style-type: none"> • Check sensor to ensure that it is in acceptable range. • Check sensor for proper resistance. • Replace sensor if shorted, open or out-of-calibration.
OFF	7	OFF	Discharge line sensor (RT5) error	All system functions will continue to run for 3 minutes, then terminate. Indoor fan will continue to run.	<ul style="list-style-type: none"> • Check sensor for proper resistance. Sensor should be in acceptable range. Replace sensor if shorted, open or out-of-calibration.
OFF	8	OFF	Coil target temperature achieved after unit startup.	Normal system function	Normal system function
OFF	9	OFF	Outdoor coil blockage or low refrigerant due to leak.	All system functions are terminated except indoor fan.	<ul style="list-style-type: none"> • Check for proper clearances around outdoor unit. • Check outdoor coil for and clean, if necessary.
OFF	11	OFF	Frequency limiting module temperature	All system functions are terminated except indoor fan.	<ul style="list-style-type: none"> • Verify proper attachment of heat sink. • Clean heat sink, if necessary.

Continued — 9-12 kBtu System Status and Error Codes — Outdoor LEDs

Outdoor LED Displays (number of blinks)			Description	System Status	
Yellow	Red	Green			
OFF	13	OFF	Power issue	Compressor speed automatically adjusted to match conditions.	System power issue. See figure 77.
OFF	14	OFF	Outdoor DC fan motor malfunction	All system functions are terminated.	<ul style="list-style-type: none"> Check wiring between fan motor and outdoor control terminal marked OFFAN. If wiring is correct, replace outdoor DC fan motor.
1	OFF	OFF	Compressor started	Normal operation	Normal compressor operation.
2	OFF	OFF	Defrosting (heat pump only)	Normal operation	Normal defrost operation.
3	OFF	OFF	Indoor coil freeze protection	All system functions are terminated except indoor fan. The indoor coil sensor (RT2) monitors the coil temperature continuously. If coil temperature drops below 30.2°F (-1°C), the compressor and the outdoor fan (30 seconds later) are switched off. Condition is cleared when indoor coil temperature rises above 42.8°F (6°C) and the compressor has been off for a minimum of three minutes.	<ul style="list-style-type: none"> Check for restricted indoor airflow and change filter, if necessary. Check for restricted refrigerant flow. Check for low outdoor ambient temperature or low indoor system load.
4	OFF	OFF	Intelligent Power Module (IPM) module protection	All system functions are terminated except indoor fan.	<p>This can be caused by any of the following:</p> <ul style="list-style-type: none"> Loss of cooling to the heat sink Low voltage. High ambient temperature Loose screws fastening the outdoor control to the heat sink
5	OFF	OFF	Compressor over-current protection	All system functions are terminated except indoor fan.	<ul style="list-style-type: none"> Check for locked compressor rotor due to excessively high ambient temperature. Check for restricted refrigerant flow due to blocked capillary tubing. Check outdoor unit to make sure that coil is not blocked.
6	OFF	OFF	Compressor high temperature protection	All system functions are terminated except indoor fan.	<ul style="list-style-type: none"> Check for proper wiring connections and loose wires at outdoor control (CT1, 2) input plug. Check for continuity across overload protection sensor terminals mounted at top of compressor.
7	OFF	OFF	Discharge line temperature protection	Sensor RT5 monitors compressor discharge line temperature and communicates with outdoor unit microprocessor. Depending on the temperature measured, the compressor speed will be increased to meet the load or will continue to run at the existing speed. If the temperature becomes excessively high, the compressor will be de-energized. When the compressor discharge temperature drops below 194°F (90°C), the unit will resume normal operation. See figure 61.	<ul style="list-style-type: none"> Check for low refrigerant charge. Check for restricted refrigerant flow due to blocked capillary.
8	OFF	OFF	Compressor overload protection sensor (CT1,2) malfunction.	All system functions are terminated except indoor fan.	<ul style="list-style-type: none"> Check for proper wiring connections and loose wires at outdoor control (CT1, 2) input plug. Check for continuity across overload protection sensor terminals mounted at top of compressor.
9	OFF	OFF	Power factor protection	All system functions are terminated.	Indoor unit is experiencing either a high or low input voltage condition. <ul style="list-style-type: none"> Verify proper input voltage at terminal strip N(1) and 3.
11	OFF	OFF	EEPROM failure	All system functions are terminated.	<ul style="list-style-type: none"> Replace outdoor control.

Continued — 9-12 kBtu System Status and Error Codes — Outdoor LEDs

Outdoor LED Displays (number of blinks)			Description	System Status	
Yellow	Red	Green			
12	OFF	OFF	Low voltage protection	All system functions are terminated.	<ul style="list-style-type: none"> • Check input voltage on outdoor unit terminal strip (N and L terminals).
13	OFF	OFF	High voltage protection	All system functions are terminated.	<ul style="list-style-type: none"> • Check input voltage on outdoor unit terminal strip (N and L terminals). • If voltage is some other value, replace capacitor. • If voltage is some other value, replace capacitor. • If input voltage and capacitor are normal, replace outdoor control.
14	OFF	OFF	Power factor correction protection	System will continue to operate at reduce compressor speed until issue is corrected.	<ul style="list-style-type: none"> • See figure 80 for troubleshooting.
16	OFF	OFF	Indoor and outdoor unit mismatch	All system functions are terminated.	The two system components are mismatched. Refer to engineering handbook for correct match-up.

Refrigerant System Flow Diagrams

The following two diagrams illustrate refrigerant flow in either cooling or heating (heat pump only) operations.

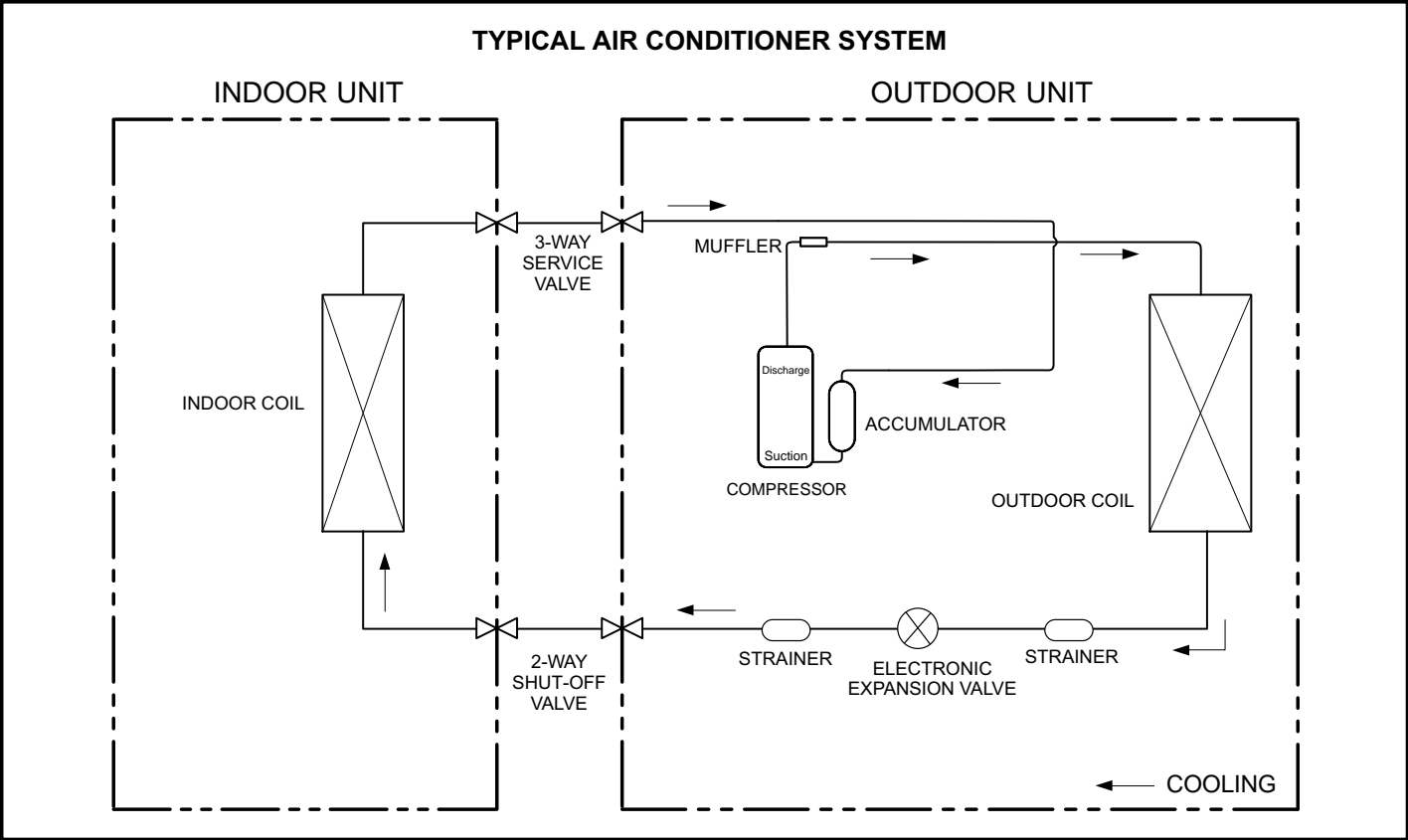

FIGURE 69

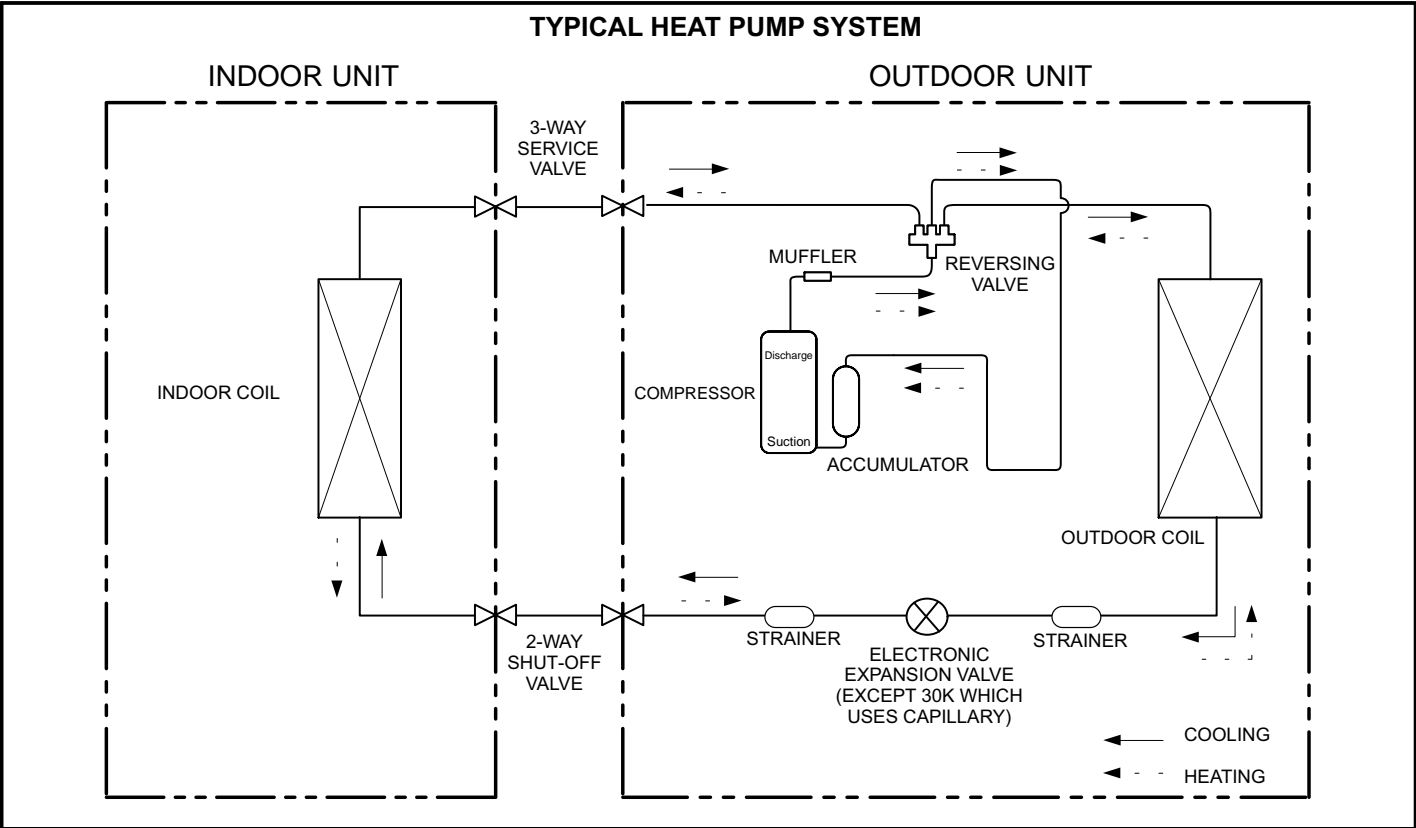

FIGURE 70

Typical Unit Wiring Diagrams

The indoor wiring diagram location is on the inside of the cabinet at the terminal connection end. To access the diagram will required removal of the cabinet. The wiring diagram on the outdoor unit is located on the top of the control box.

WARNING



Electric Shock Hazard. Can cause injury or death. Unit must be grounded in accordance with national and local codes.

Line voltage is present at all components when unit is not in operation. Disconnect all remote electric power supplies before opening access panel or cover. Unit may have multiple power supplies.

TYPICAL INDOOR UNIT WIRING DIAGRAM — 09 - 12 KBTU SYSTEMS (115V)



REMOVE CABINET FROM CHASSIS AND THE WIRING DIAGRAM IS LOCATED HERE.

REMOVE UNIT TOP COVER. THEN REMOVE ACCESS COVER TO OUTDOOR CONTROL. TO VIEW THE WIRING DIAGRAM LOCATED ON THE UNDERSIDE OF THE ACCESS COVER.



FIGURE 71

WARNING



Delayed Electric Shock Hazard

Capacitors in this unit may hold charge. Do not remove this cover or service this area for 2 minutes after the main power has been removed.

TYPICAL INDOOR UNIT WIRING DIAGRAM — 09 - 12 KBTU SYSTEMS (115V)

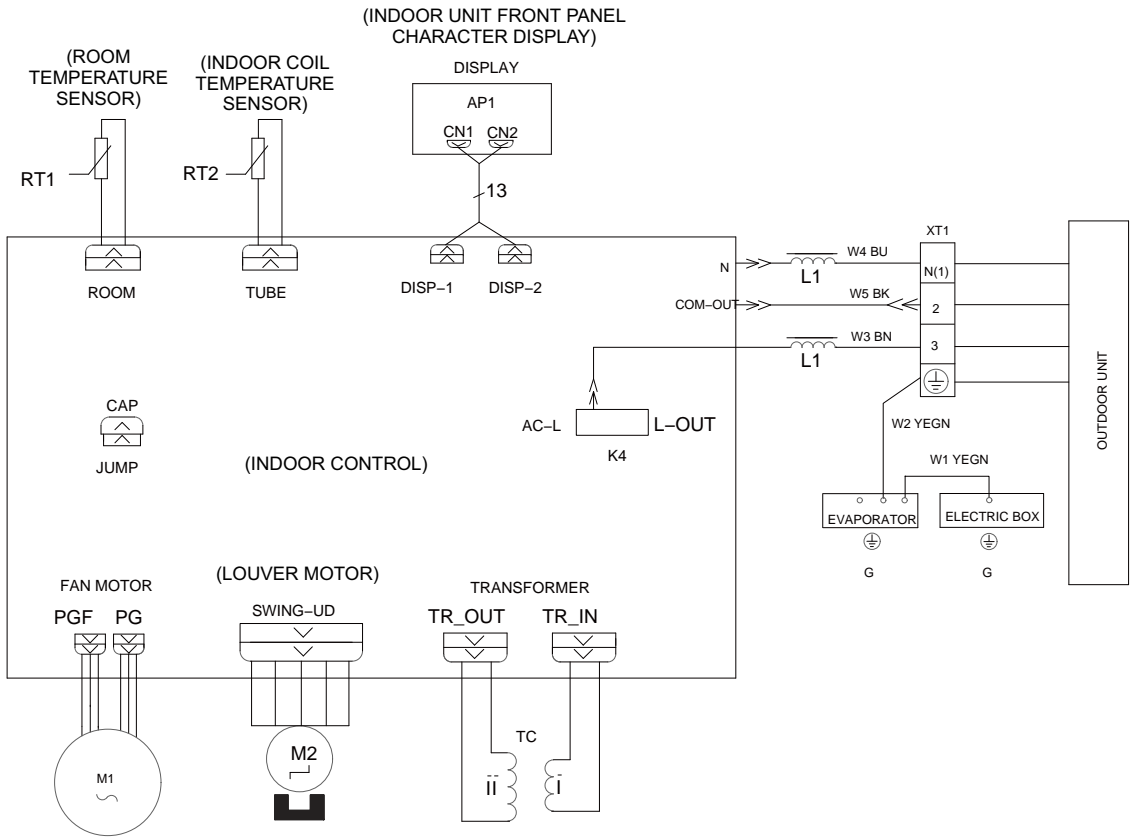

FIGURE 72

TYPICAL OUTDOOR UNIT (AIR CONDITIONER) WIRING DIAGRAM (115V) — 09 - 12 KBTU SYSTEMS

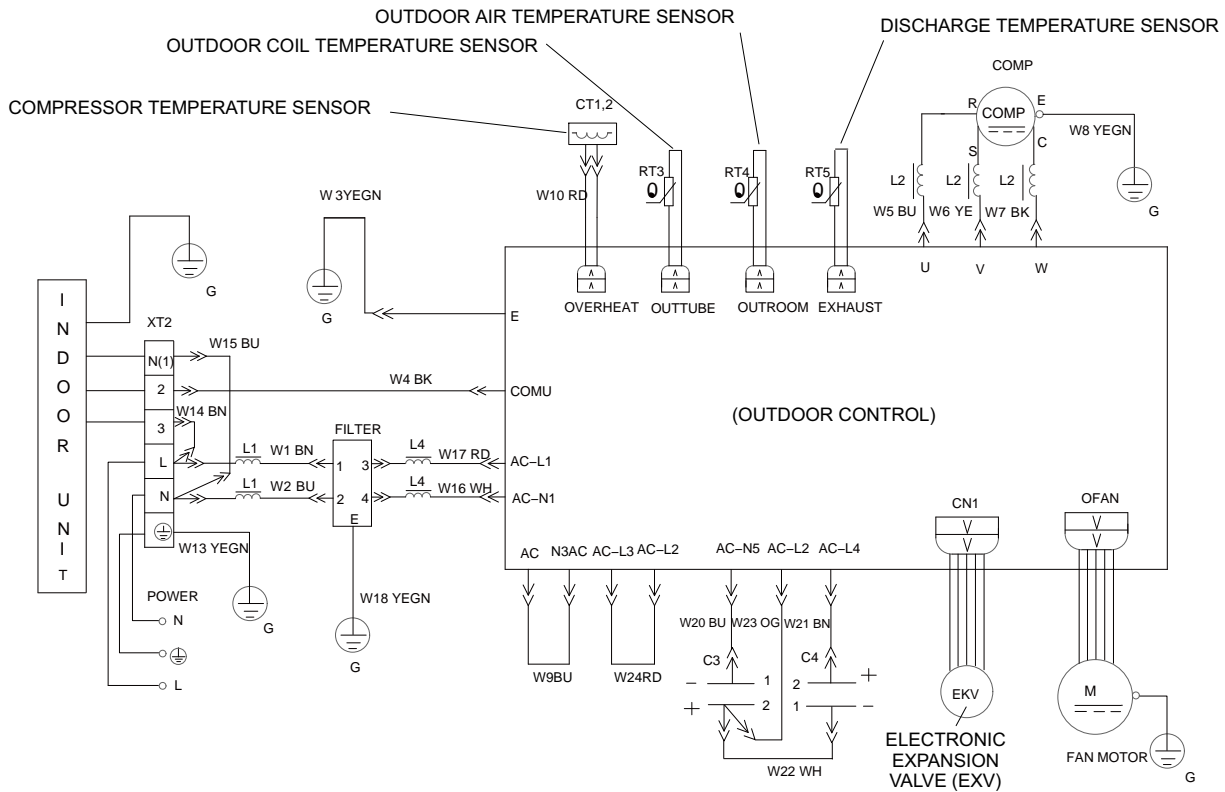

FIGURE 73

TYPICAL OUTDOOR UNIT (HEAT PUMP) WIRING DIAGRAM (115V) — 09 - 12 KBTU SYSTEMS

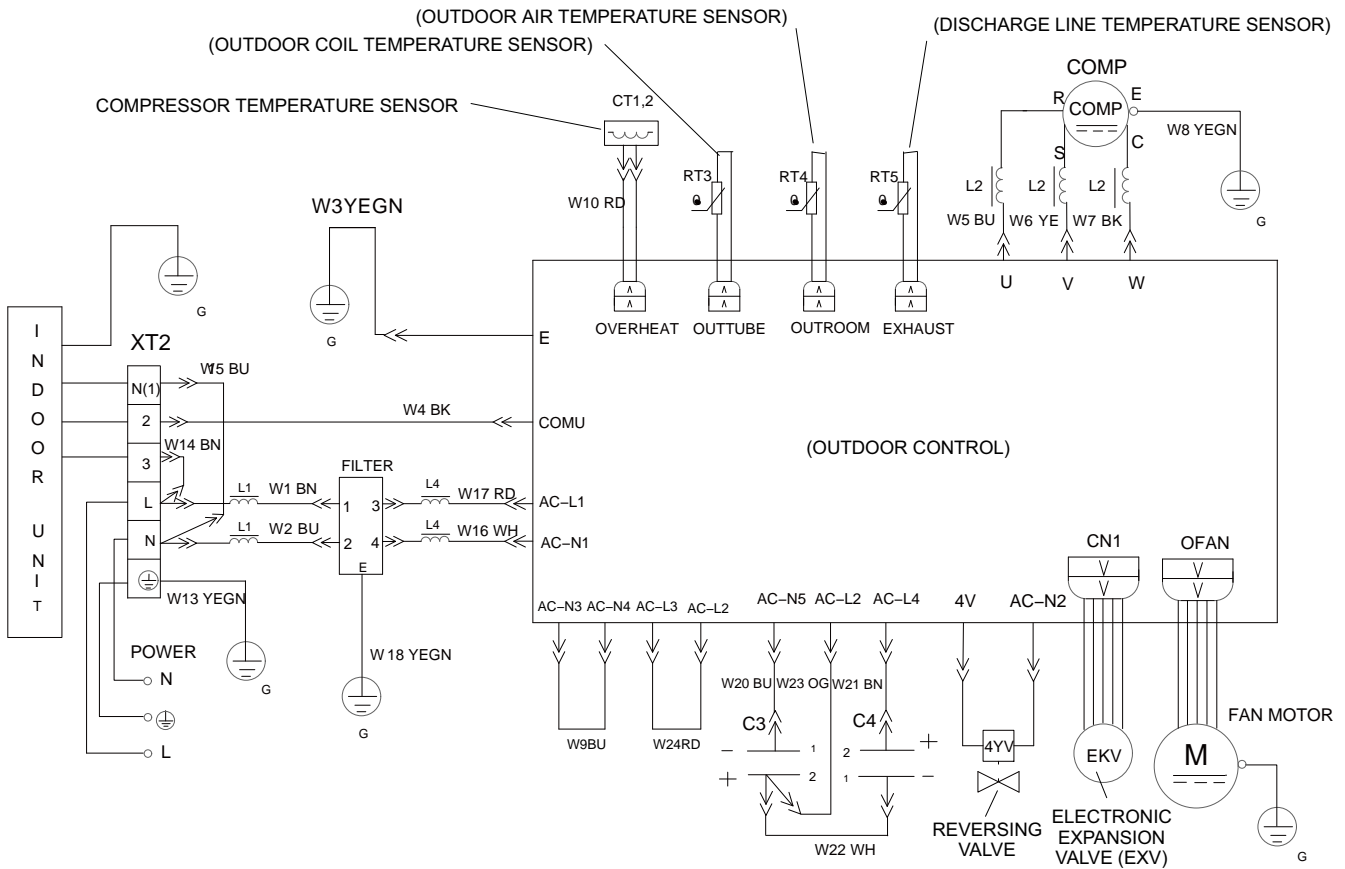

FIGURE 74

Troubleshooting

SYSTEM FAILED START UP (ALL SIZES)

APPLICABLE UNIT SIZE(S): All

APPLICABLE ERROR CODE(S): NONE

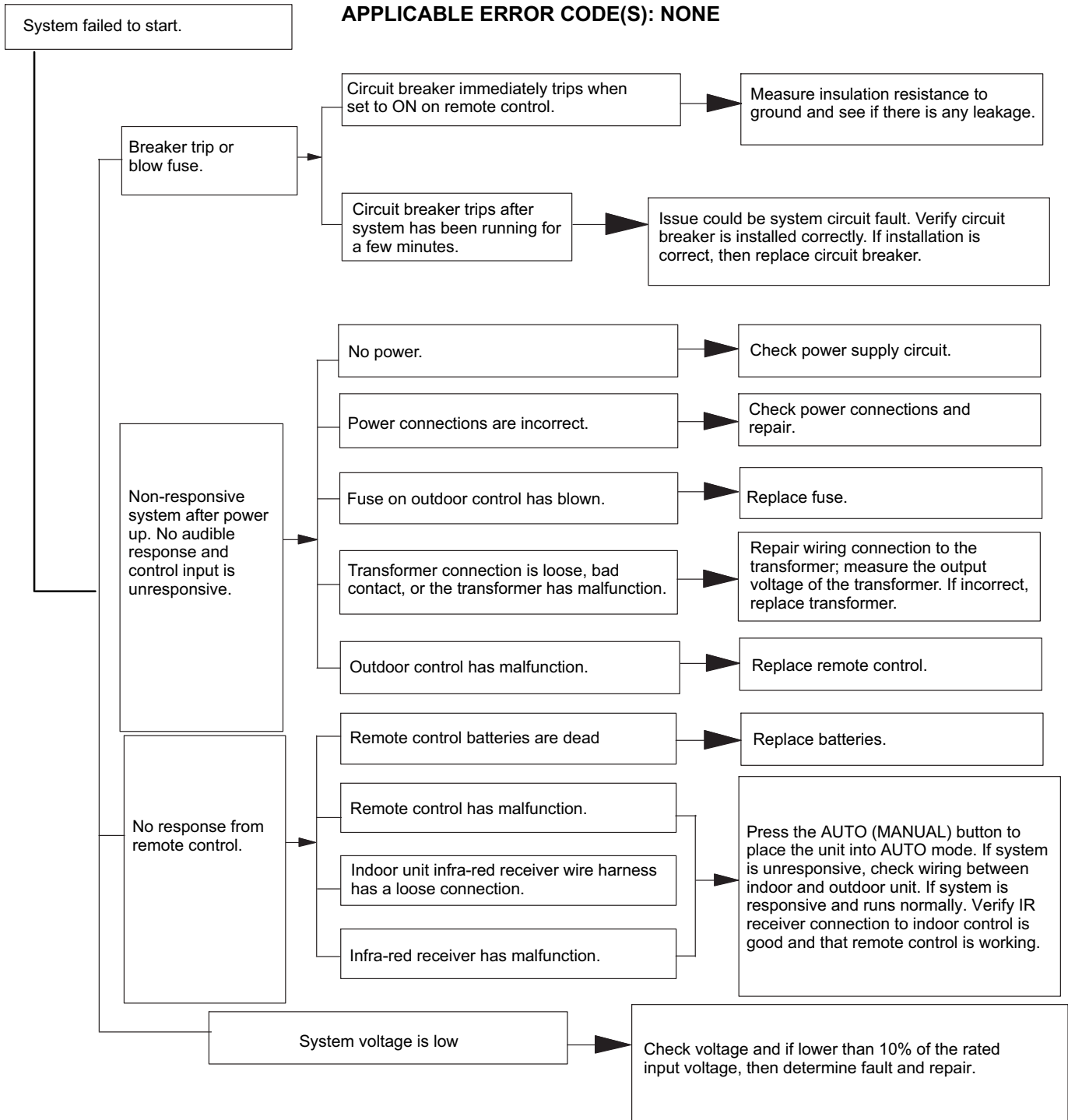

FIGURE 75

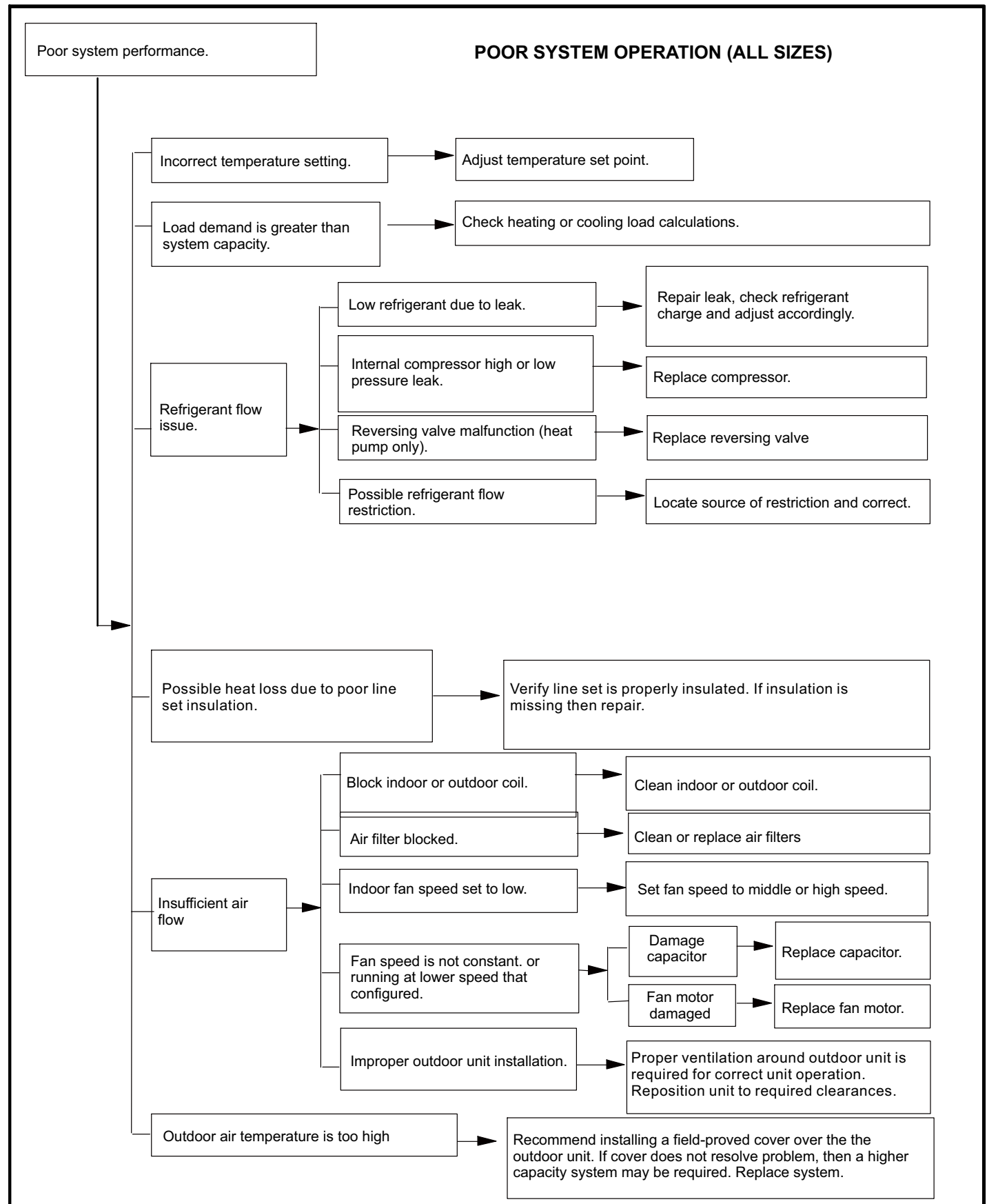

FIGURE 76

POOR SYSTEM OPERATION (ALL SIZES) (CONTINUED)

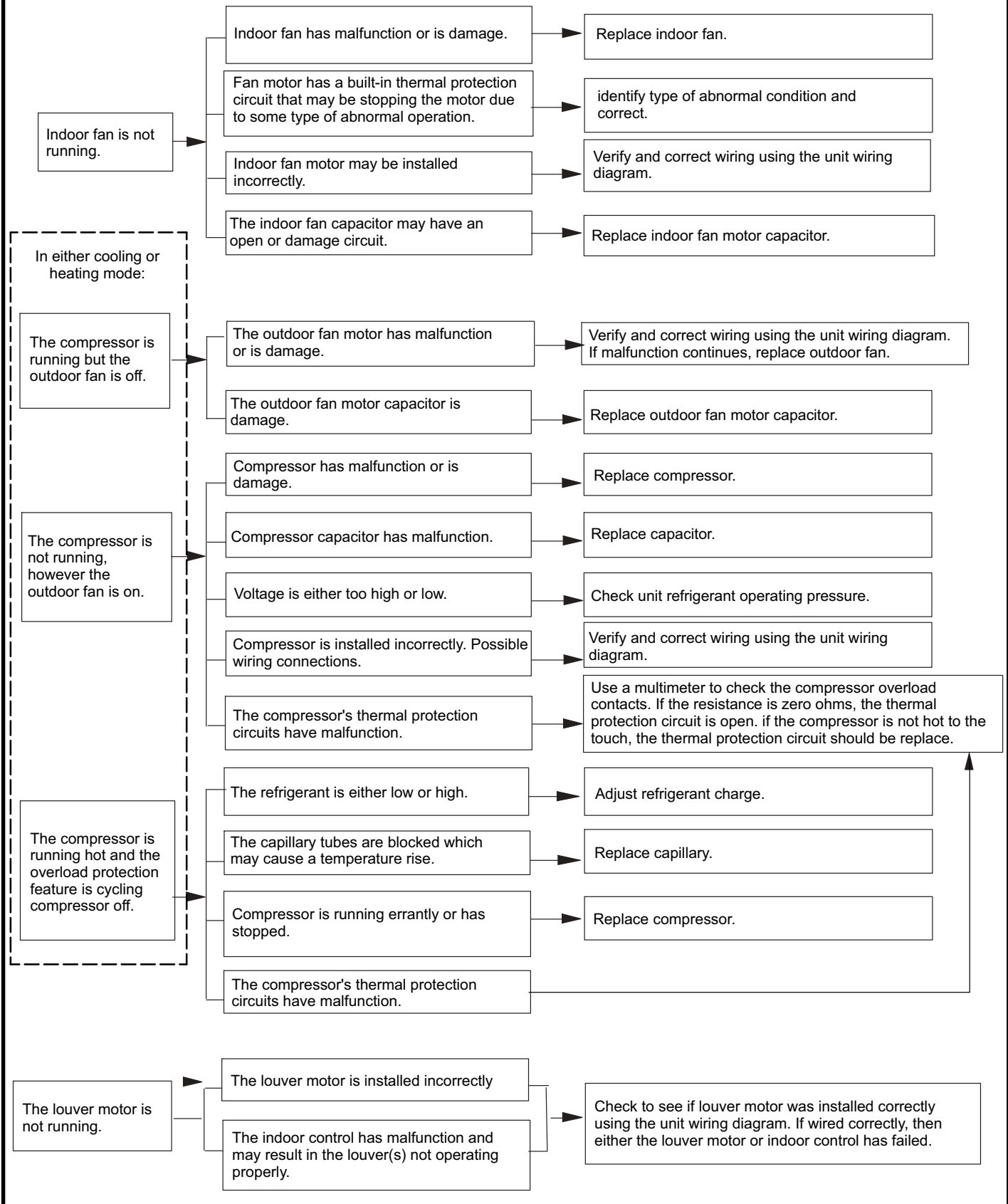

FIGURE 85

HEAT PUMP FAILED START UP (CONTINUED)

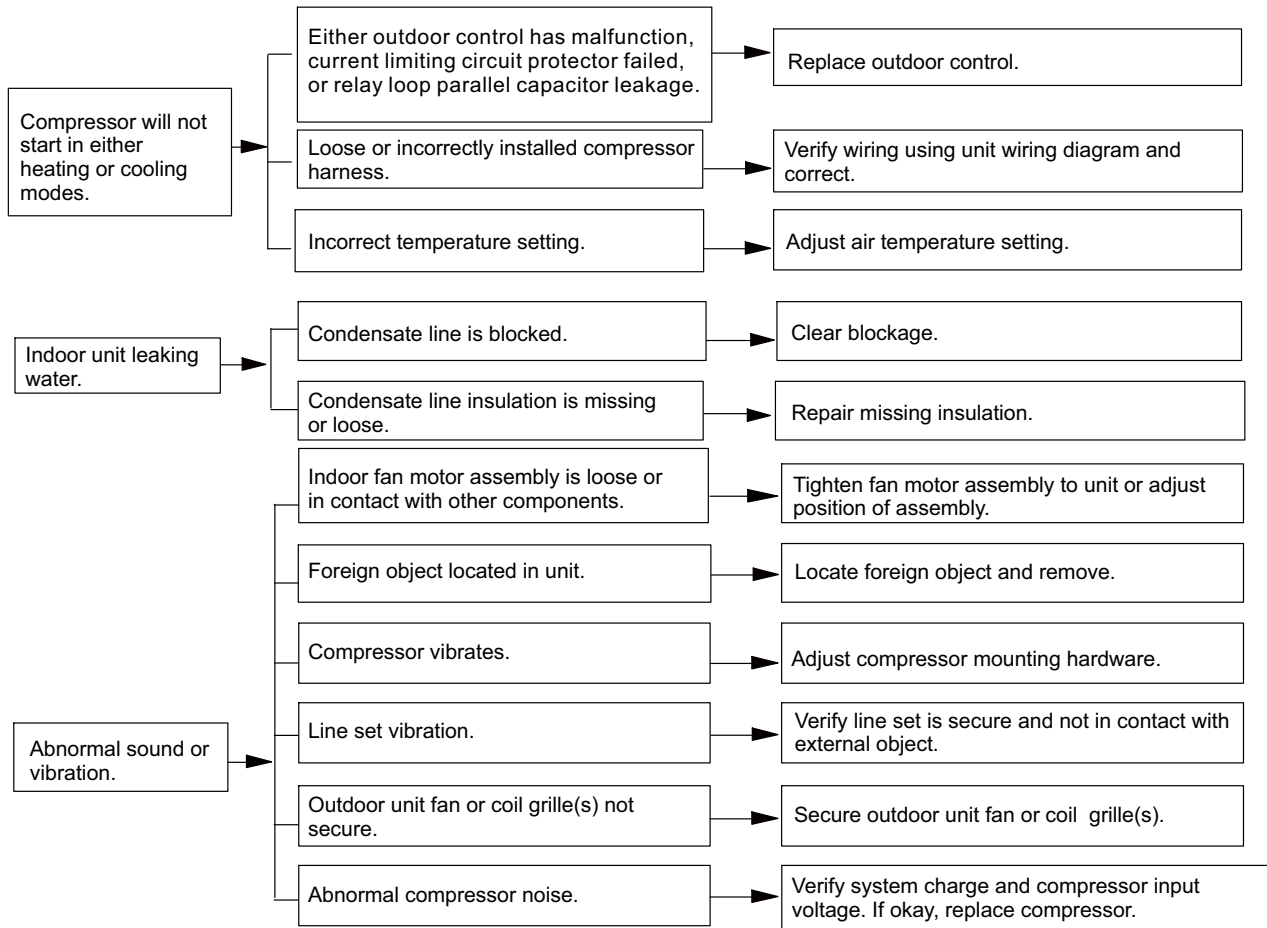

FIGURE 85

CAPACITOR CHARGE FAULT (OUTDOOR UNIT) (9-12K BTU SYSTEMS)

NOTE— Reactor (choke) line test procedure reference here is applicable for the 115V systems.

APPLICABLE ERROR CODE(S): PU, PH

VERIFY VOLTAGE

* **115VAC Systems:** Use AC voltmeter to check voltage between **L** and **N** on outdoor control.

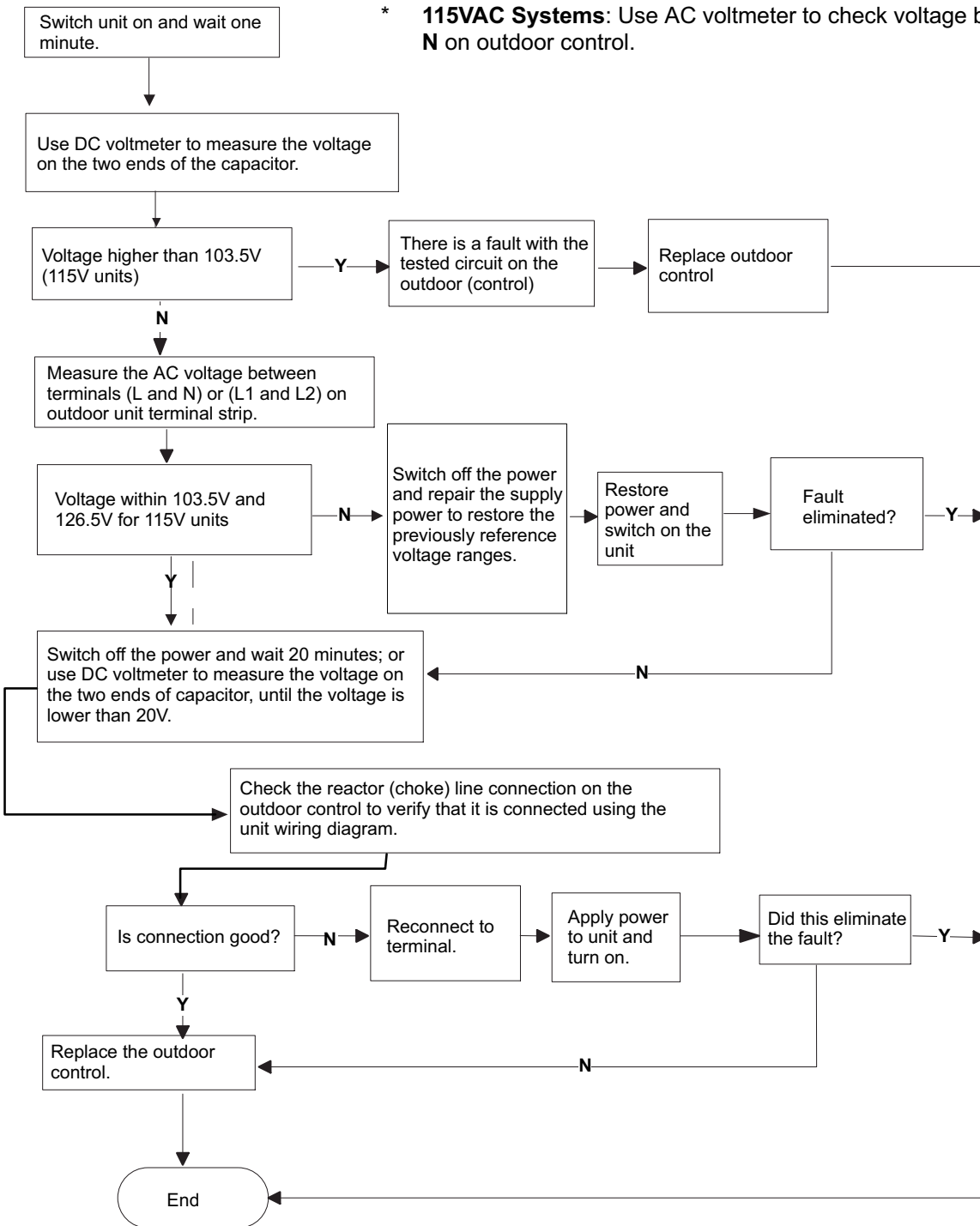

FIGURE 77

OUTDOOR UNIT HIGH TEMPERATURE AND OVERLOAD PROTECTION

APPLICABLE UNIT SIZE(S): All

APPLICABLE ERROR CODE(S): E1, E5, H4

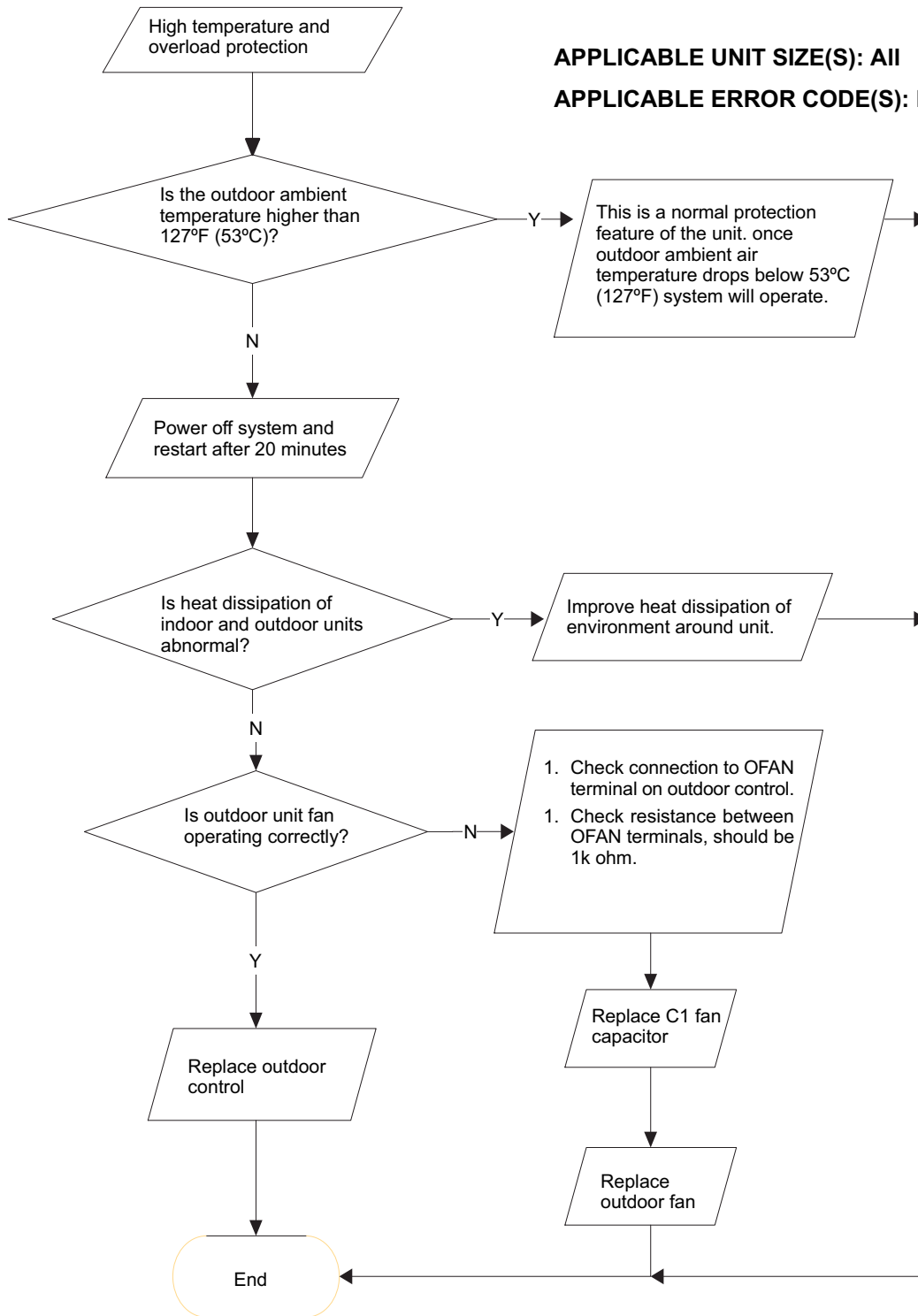

FIGURE 78

OUTDOOR UNIT OVERLOAD AND DISCHARGE LINE SENSOR MALFUNCTION

APPLICABLE UNIT SIZE(S): All

APPLICABLE ERROR CODE(S): E4, H4

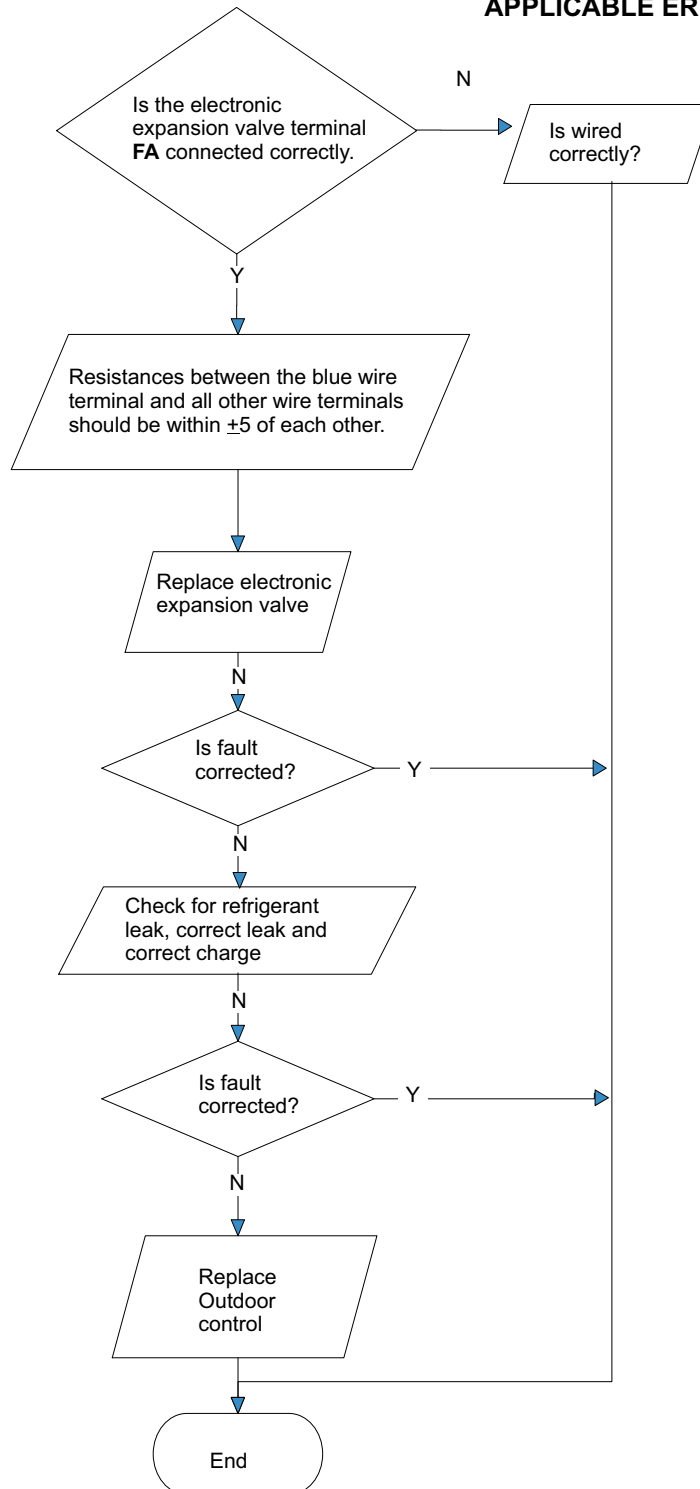

FIGURE 79

OUTDOOR POWER FACTOR CORRECTION FAULT

APPLICABLE UNIT SIZE(S): All

APPLICABLE ERROR CODE(S): HC

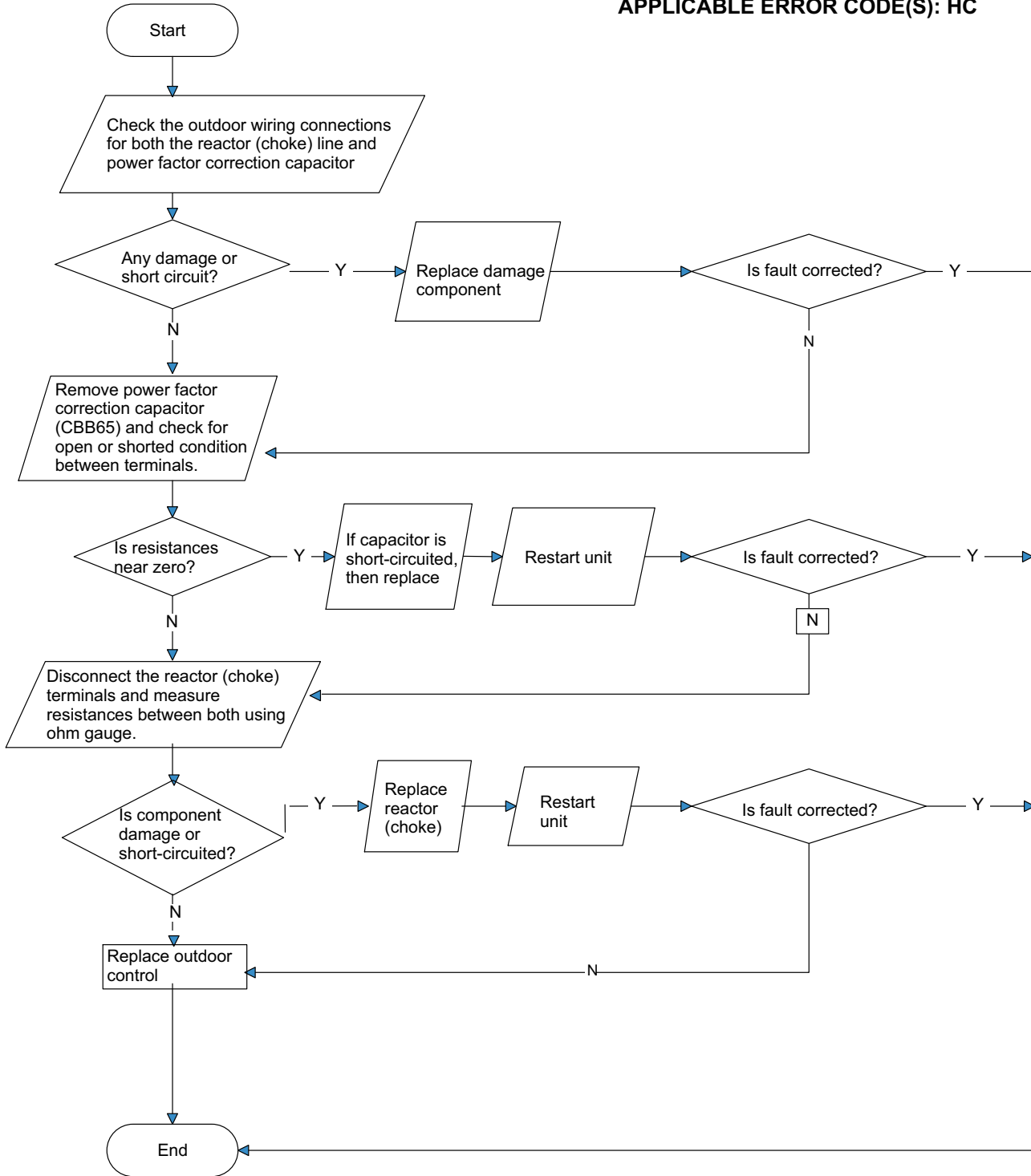

FIGURE 80

INTER-UNIT COMMUNICATION ERROR

APPLICABLE UNIT SIZE(S): All

APPLICABLE ERROR CODE(S): E6

See page 80 for procedure for testing communication line.

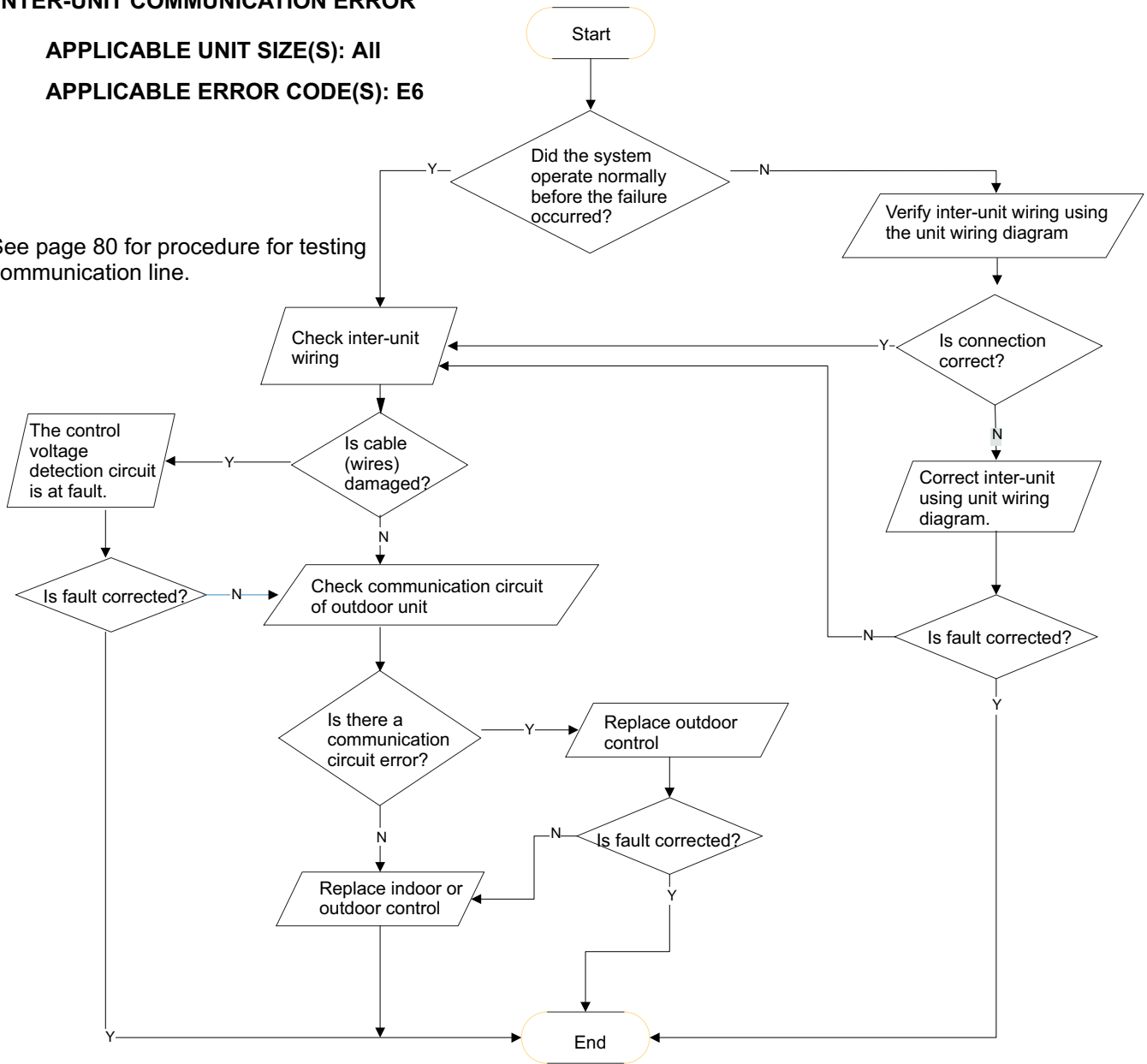

FIGURE 81

Major System Components

This section describes the following system components.

1. COMPONENT: INDOOR FAN MOTOR

DESCRIPTION:

The indoor fan is driven by a single-phase (115V) AC motor. The motor adopts step-less speed regulation to operate at different speeds. The motor speeds are determined by the output voltage and frequency signal from the indoor control. A Hall effect sensor, that is located in the end of the motor, feeds back information to the indoor control to confirm that the indoor motor is operating at the requested RPM.

TROUBLESHOOTING:

Check wiring connections at indoor control.

Measure resistance between the plug-in pins (if reading show open or shorted, replace fan motor). Measure resistance between leads red to brown, red to white and brown to white. If resistance is 0 ohms or infinite, replace motor.

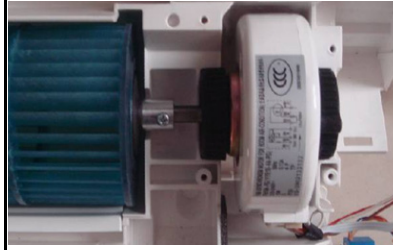

PHOTO OF INDOOR FAN MOTOR NAME PLATE (18-24 KBTU UNITS)

2. COMPONENT: INDOOR LOUVER MOTOR (SWING MOTOR)

DESCRIPTION:

A stepper motor (or step motor) is a brush less, electric motor that can divide a full rotation into a large number of steps. The louver motor operates on a 12 VDC input to vary the indoor air discharge louver to a programmed setting. Stepper motors effectively have multiple toothed electromagnets arranged around a central gear-shaped piece of iron. The electromagnets are energized by an external control circuit, such as a microcontroller. To make the motor shaft turn, first one electromagnet is given power, which makes the gear's teeth magnetically attracted to the electromagnet's teeth. When the gear's teeth are thus aligned to the first electromagnet, they are slightly offset from the next electromagnet. So when the next electromagnet is turned on and the first is turned off, the gear rotates slightly to align with the next one and from there the process is repeated. Each of those slight rotations is called a step, with an integer number of steps making a full rotation. In that way, the motor can be turned a precise angle.

TROUBLESHOOTING:

- * Check wiring connections at indoor control.
- * Measure resistance between the plug-in pins (if readings show open or shorted, replace motor). Normal reading between red-pink, red-blue, red-orange and red-yellow should be approximately 135 ohms \pm 10%.

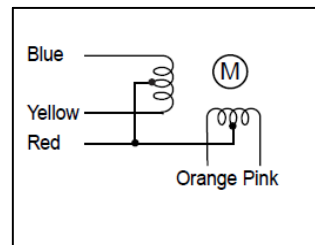
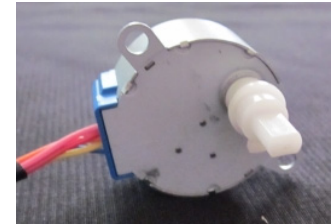

3. COMPONENT: OUTDOOR FAN MOTOR

ELECTRICAL CHARACTERISTICS:

- * **Power supply:** 100~120V
- * **Frequency:** 60Hz
- * **Number of poles:** 2 or 4
- * **Output power:** 90W.
- * **Description:**
 - Single-phase capacitor run asynchronous DC motor with iron shell. This type of motor is reliable, highly efficient, well structure, low noise output with minimum vibration attributes.
 - Run capacitor separate remotely mounted in the of outdoor board

TROUBLESHOOTING:

Measure resistance between wire leads. If resistance is 0 ohms or infinite between any of the wire leads, replace motor.

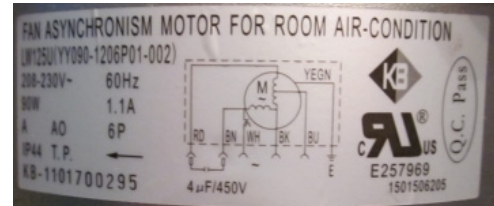
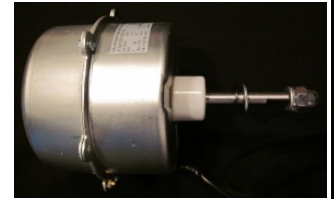

PHOTO OF OUTDOOR FAN MOTOR NAME PLATE (18-24 KBTU UNITS)

4. COMPONENT: ROTARY COMPRESSOR WITH ACCUMULATOR

DESCRIPTION:

The rotary compressor is a 3-phase, direct-current (DC) compressor. In a rotary compressor the refrigerant is compressed by the rotating action of a roller inside a cylinder. The roller rotates eccentrically (off-center) around a shaft so that part of the roller is always in contact with the inside wall of the cylinder. A spring-mounted blade is always rubbing against the roller. The two points of contact create two sealed areas of continuously variable volume inside the cylinder. At a certain point in the rotation of the roller, the intake port is exposed and a quantity of refrigerant is sucked into the cylinder, filling one of the sealed areas. As the roller continues to rotate the volume of the area the refrigerant occupies is reduced and the refrigerant is compressed. When the exhaust valve is exposed, the high-pressure refrigerant forces the exhaust valve to open and the refrigerant is released. Rotary compressors are very efficient because the actions of taking in refrigerant and compressing refrigerant occur simultaneously.

TROUBLESHOOTING:

Check wiring connections at outdoor control board plug-in and terminals of compressor.

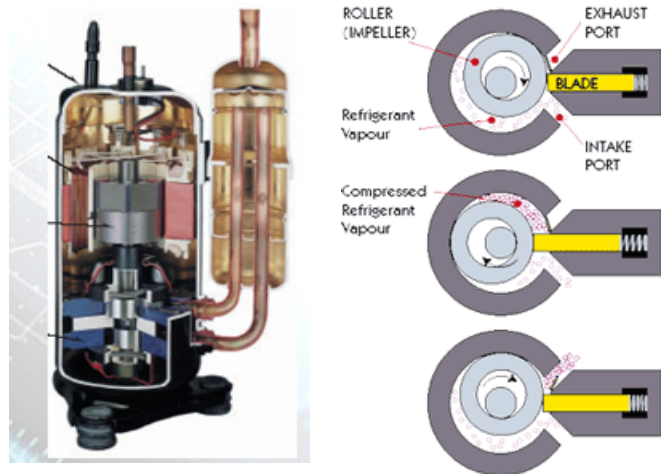

COMPRESSOR OVERLOAD (SAT)



COMPRESSOR TERMINALS (U, V, W)

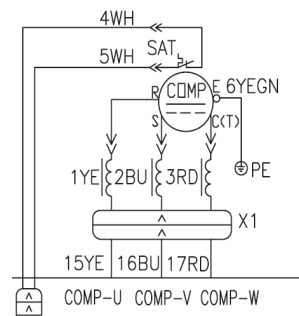

OUTDOOR CONTROL

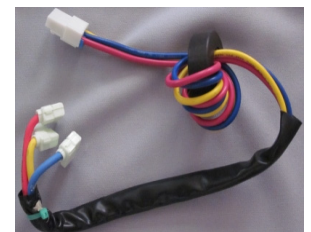

COMPRESSOR HARNESS WITH FERRITE (X1)

5. COMPONENT: ROTARY COMPRESSOR WITH ACCUMULATOR (CONTINUED)

TROUBLESHOOTING (CONTINUED):

Check winding resistance of each terminal. If resistance value is 0 ohms or infinite, replace compressor.

RESISTANCE BETWEEN EACH SET OF WINDINGS SHOULD BE EQUAL.

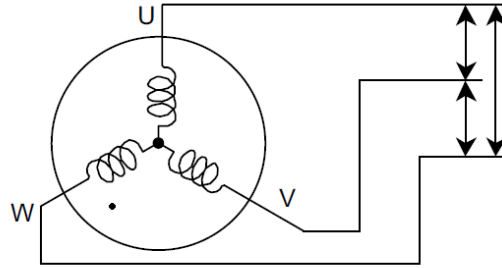
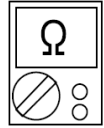

6. COMPONENT: COMPRESSOR TEMPERATURE OVERLOAD PROTECTION

DESCRIPTION:

If temperature detected by the overload sensor exceeds 239°F (115°C), the compressor will stop and the outdoor fan will stop after a delay of 30 seconds. Once the compressor temperature drops below 204°F (95°C), the compressor overload protection feature will reset and the system will resume normal operations.

TROUBLESHOOTING:

- * Check wiring connections at compressor terminals and at the outdoor control.
- * Check control SAT to determine if it is closed or open. If resistance is infinite ohms, then the overload control is closed. If the resistance is 0 ohms, then the overload control is CLOSED. If the compressor is not hot to the touch, then the overload control assembly should be replaced.

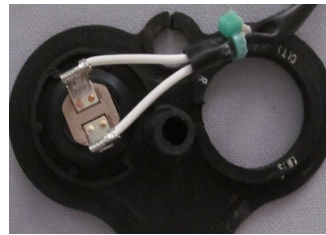

COMPRESSOR OVERLOAD ASSEMBLY (SAT)

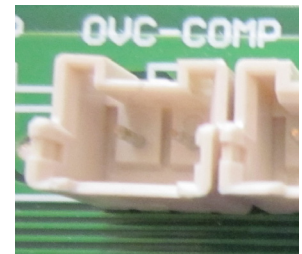

OUTDOOR CONTROL CONNECTION

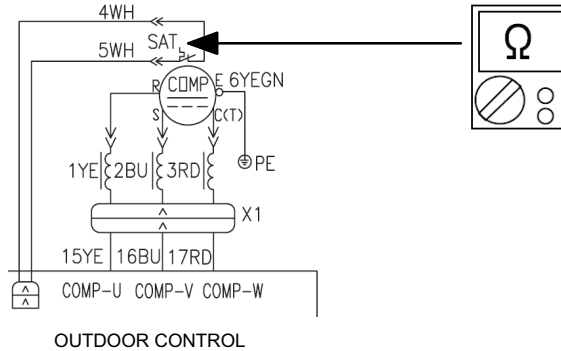

OUTDOOR CONTROL

8. COMPONENT: ELECTRONIC EXPANSION VALVE

DESCRIPTION:

Electronic expansion valve is used in Inverter air conditioning system to adjust flow of refrigerant automatically. Thus the air conditioner can always stay at the optimized working conditions with quick cooling, precise temperature control, low energy consumption, etc. This valve is reversible and can control the flow under either cooling or heating condition.

Electronic Expansion Valve (EXV) is mainly composed of valve body and 12 VDC, rectangular wave coil. The controller in the air conditioning system can control the step motor of EXV to synchronize the turning of gear train which converts the rotation of gears to a pull/push force and moves the valve pin axially which can change the flow area and flow of refrigerant accordingly.

The outdoor control sends pulse signal to the coil which controls the rotor synchronizing the turning of feed screw and nut, converting the rotation to movement of valve pin. Thus the flow area and flow of refrigerant will be changed accordingly.

The EXV is driven by permanent-magnet (PM) type step motor (claw pole field motor) which consists of two relative separate parts: 1) step motor coil; 2) multi-pole rotor valve body. The coil is fixed onto the body through a clipper.

TROUBLESHOOTING:

Check opening and closing operation of valve. Check operation of valve by measuring temperature differences between the inlet and outlet pipes of the EXV.

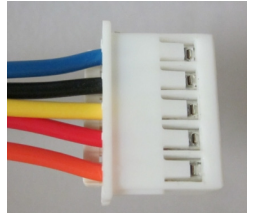

Check resistance between blue-black, blue-yellow, blue-red and blue-orange. All resistance readings should be within ± 5 of each other.

When Valve is closed,
it has a temp. difference between Inlet and Outlet.

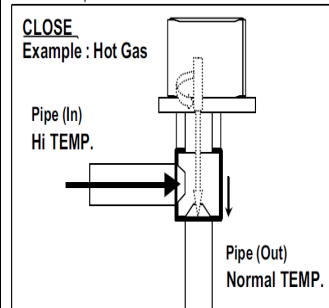

If it is open,
it has no temp. difference between Inlet and Outlet.

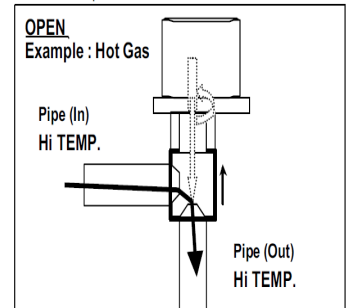

10. COMPONENT: REVERSING VALVE (HEAT PUMP ONLY)

DESCRIPTION:

The 4-way reversing valve is a component that switches the system between cooling and heating modes. By switching the flow of refrigerant, the heat pump can incorporate the functions of cooling in summer and heating in winter together. The 4-way reversing valve consists of main and pilot valves, and a solenoid coil.

Any of the following starting conditions are required to actuate the reversing valve for a specific operating condition.

NOTE — The reversing valve is energized in heating mode.

STARTING CONDITIONS:

1. When entering heating mode on start up.
2. When changing from cooling to heating mode.
3. When entering defrost mode.
4. When entering heating mode after defrost.

TROUBLESHOOTING:

Using a multimeter set to ohms, insert the test lead probes into the plug end of the reversing valve coil. If resistance value is between 950 to 1500 ohms then the reversing valve is good. If not within the specified range, replace reversing valve.

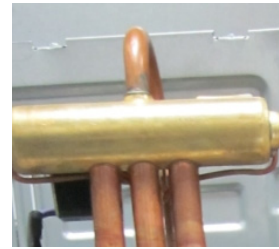

REVERSING VALVE BODY



REVERSING VALVE 220-240 VOLT COIL

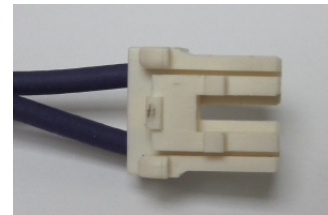

POWER CONNECTOR FOR REVERSING VALVE (TYPICALLY PLUGGED INTO THE OUTDOOR CONTROL 4V JACK)

12. COMPONENT: STRAINERS

DESCRIPTION:

Mesh strainers are required on the inlet and outlet of the electronic expansion valve to prevent debris from entering the valve.

TROUBLESHOOTING:

Normally strainers should not have any temperature differences between the inlet and outlet as shown in item 1 below. However if a temperature differences is detected then the strainer may be clogged. If strainer is clogged, replace strainer.



STRAINERS

ITEM 1

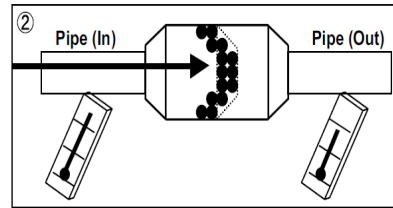
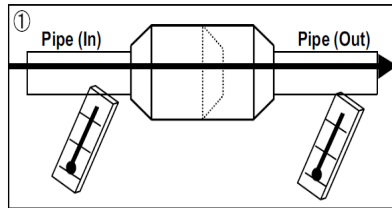

13. COMPONENT: REACTOR (CHOKE)

DESCRIPTION:

Choke coils are inductances that isolate AC frequency current from certain areas of a radio circuit. The reactor (choke) depend upon the property of self-inductance for its operation. Chokes can be used to block alternating current while passing direct current.

TROUBLESHOOTING:

Inspect reactor (choke) for loose connections or burnt windings.



CHOKE

14. COMPONENT: FERRITES

DESCRIPTION:

Ferrites are chemical compounds consisting of ceramic material with iron oxide as their principle component. Some ferrites have magnetic properties and are used to make permanent magnets and ferrite cores for transformers which can be used in various applications.

Electronic cabling and wires, by virtue of their length-to-width ratios, are perfect natural antennas. In the presence of high-speed microprocessor signals, cable will conduct, radiate, and receive unwanted high-frequency interfering signals. Control of radio-frequency (RF) interference can be ensured by the proper placement of an insertion-loss device, such as a ferrite suppressor. They are consistently stable over time and over wide temperature ranges, and provide RF suppression without high eddy-current losses.



FERRITE



FERRITE WITH UNIT WIRING
INSTALLED

15. COMPONENT: INDOOR TRANSFORMER

DESCRIPTION:

Indoor unit contains a transformer that will convert the 115 power to 12VAC or on some units there are two output voltages. The transformer in the pictured shows a transformer that will output 12VAC (yellow wires) and 8.5VAC (white wires). Output voltages will vary with input power into transformer.



TRANSFORMER

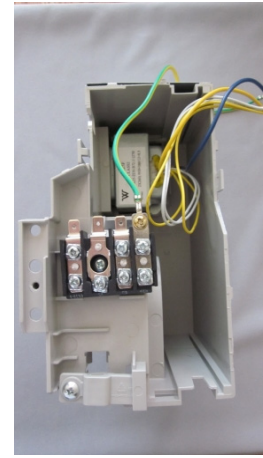

TRANSFORMER INSTALLED
IN INDOOR CONTROL
HOUSING

16. COMPONENT: INDOOR / OUTDOOR COMMUNICATION LINE

DESCRIPTION:

These units can use the same wire insulation and gauge as the main power wire into the system. The wire is routed from the outdoor unit to the indoor unit.

TROUBLESHOOTING:

The communication signal should be read between:

1. Use a true RMS meter to read between terminals 2 and neutral. The communication signal can vary from 0 ~ 70 volts AC.



Disassembly Units

This section describes how to dismantle the indoor and outdoor units down to the replacement component level.

NOTE — Due to multiple size units, some of the dismantling procedures may vary from what is shown in this section.

Step	Indoor Unit Procedure	
1. Remove the filter and front panel.		
A	<ul style="list-style-type: none"> * Open the front panel. * Loosen the clasps and raise the air filters to remove them. 	
B	<ul style="list-style-type: none"> * Remove the two screws securing the display. * Loosen the clasps and remove the indoor display panel. 	

2. Remove louver and electric box cover.

A

- * Loosen the clasp in the middle of the louver.
- * Bend the louver slightly to remove it.

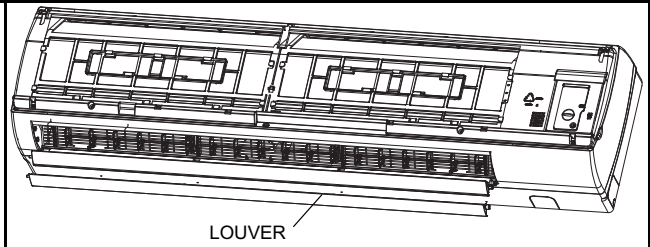

B

- * Remove the screw(s) that secure the indoor terminal strip access cover.
- * Remove the cover.

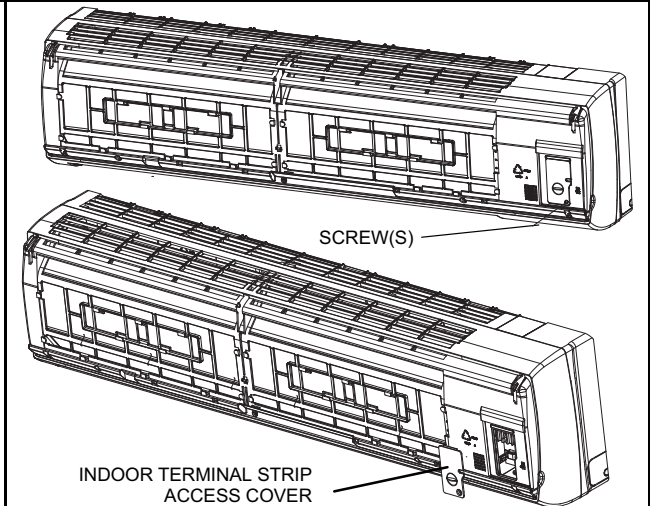

3. Remove the front case.

- * Remove the three screw covers on the front case.
- * Remove the seven screws securing the front case.
- * Remove front case.

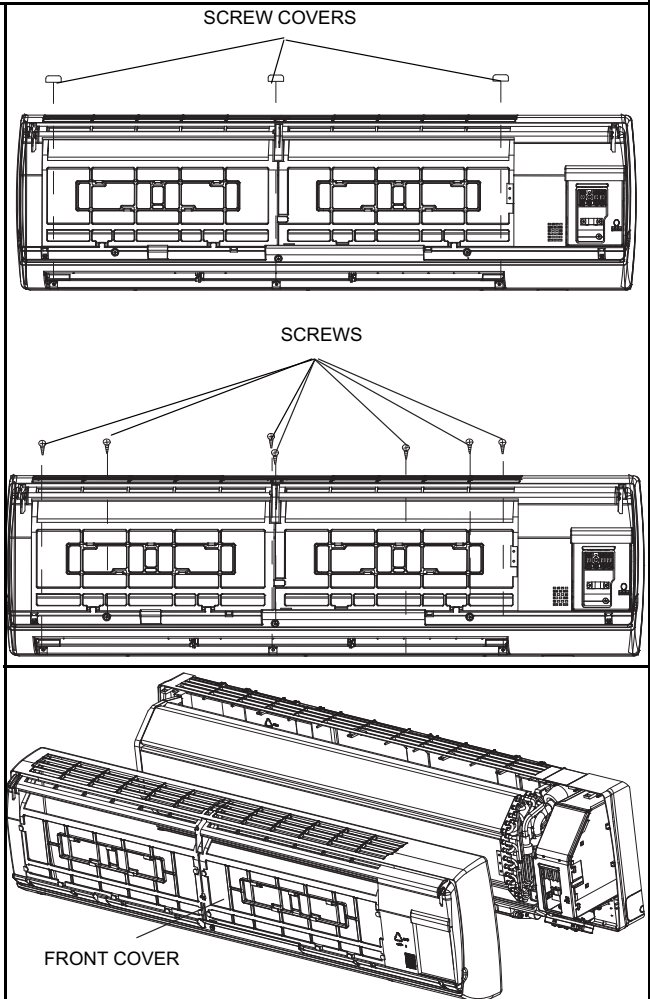

4. Remove electric box

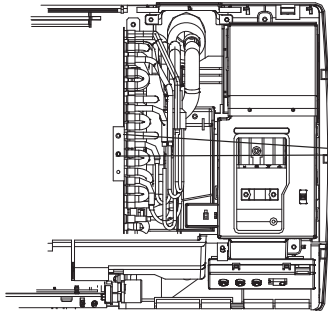
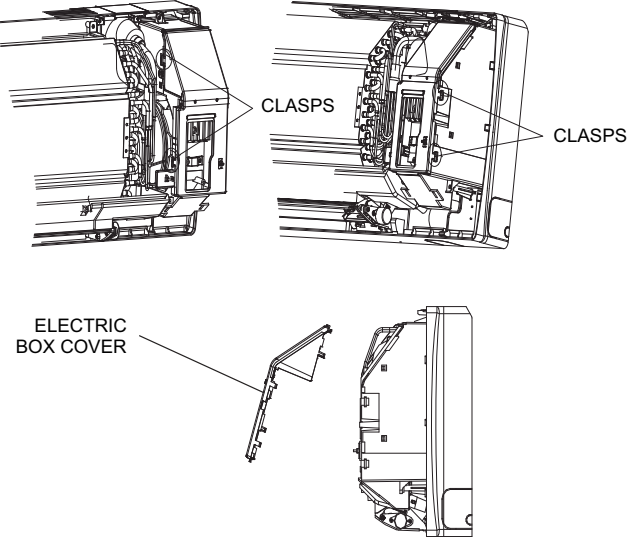
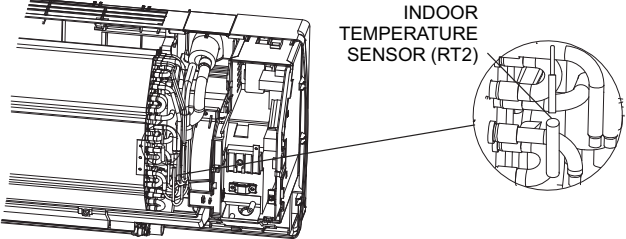
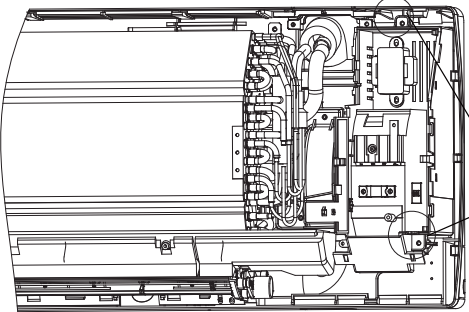
<p>A</p>	<p>Remove the screw(s) securing the ground wire.</p>	 <p>SCREWS</p>
<p>B</p>	<p>Loosen the electric box cover clasps and remove.</p>	 <p>CLASPS</p> <p>CLASPS</p> <p>ELECTRIC BOX COVER</p>
<p>C</p>	<p>Remove the air temperature sensor.</p>	 <p>INDOOR TEMPERATURE SENSOR (RT2)</p>
<p>D</p>	<p>Loosen the two screws securing the electric box and remove the box.</p>	 <p>SCREWS</p>

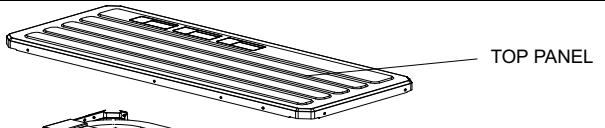
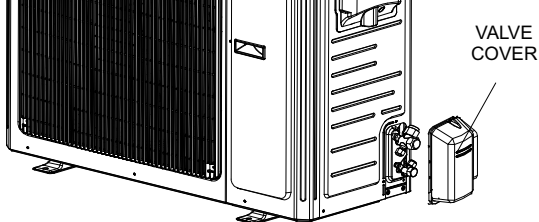
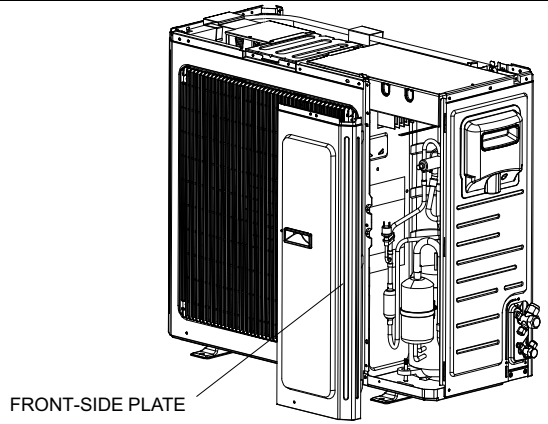
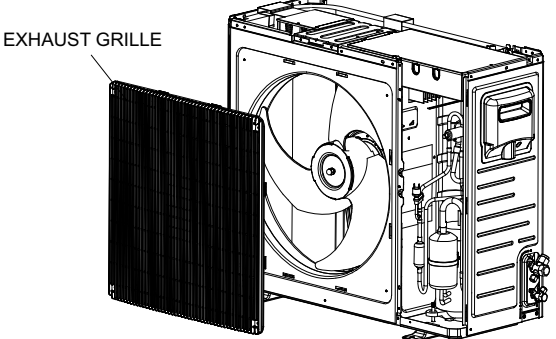
Step	Outdoor Unit Procedure	
1. Remove the top cover and front-side plates.		
A	<ul style="list-style-type: none"> * Remove the screws that secure the top panel to unit. * Remove top panel. 	
B	<ul style="list-style-type: none"> * Remove the screws that secure the valve cover to the unit. * Remove valve cover. 	
C	<ul style="list-style-type: none"> * Remove the screws securing the front-side panel to chassis. * Remove the front-side panel. 	
2. Remove exhaust grille		
	<ul style="list-style-type: none"> * Removes screws securing the exhaust grille to the unit. * Remove grille. 	

3. Remove panel

- * Remove the screws securing the coil guard to the chassis.
- * Remove coil guard.

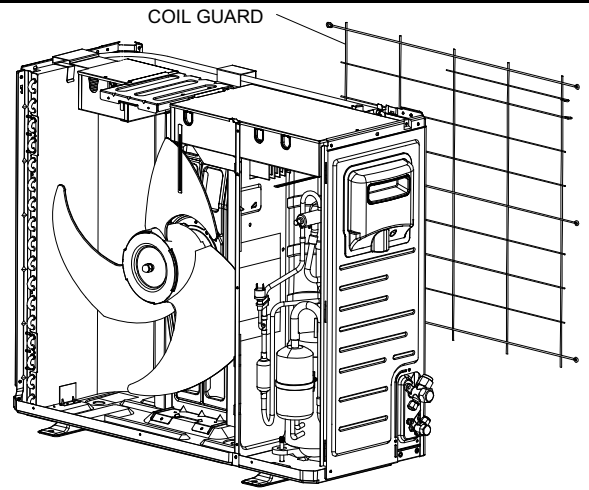

4. Remove handle

- * Remove the screws securing the handle to chassis.
- * Remove handle.

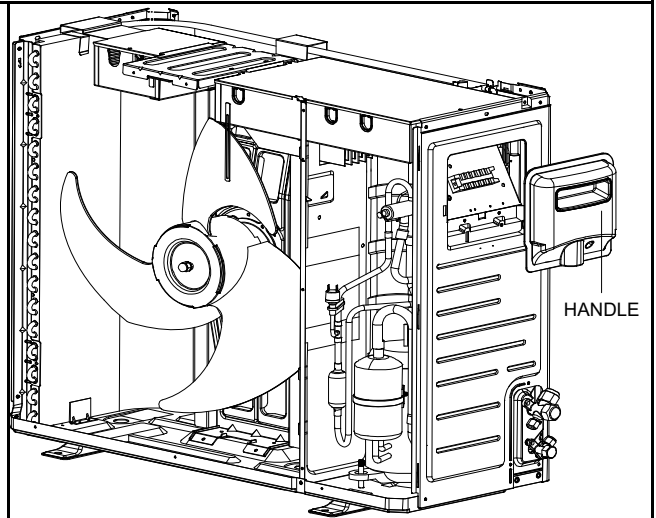

5. Remove right-side panel.

- * Remove screws securing the right-side panel to the chassis, valve support and condenser.
- * Remove right-side panel.

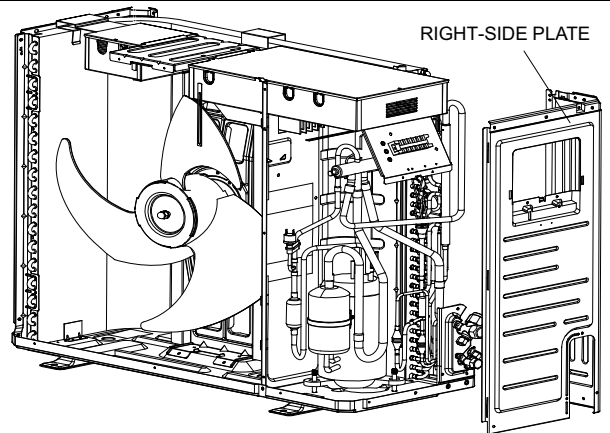

6. Remove electric box

A

- * Remove screws securing electric box cover.
- * Remove cover.

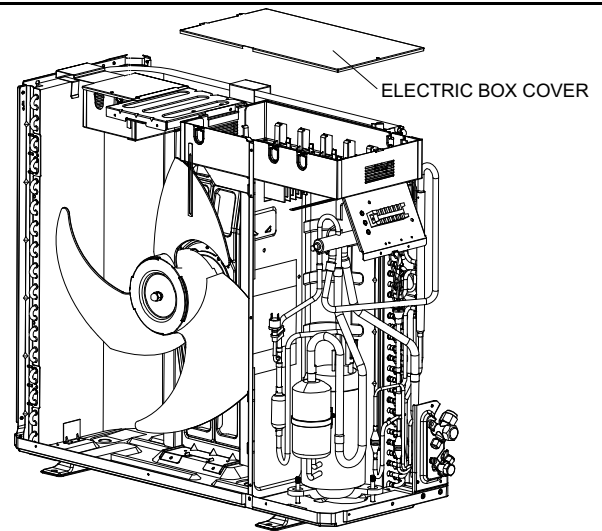

B

- * Remove screws securing the electric box.
- * Pull out the wiring terminal by cutting the tie straps.
- * Pull electric box upwards to remove.

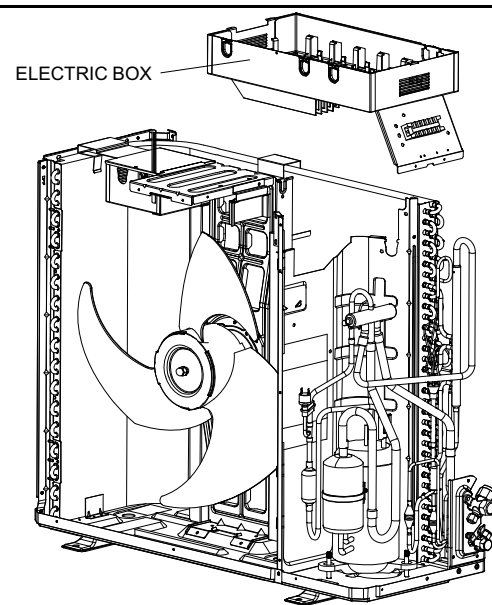

C

- * Remove screws securing the electric box 2 to the left-side plate.
- * Pull box upwards to remove.

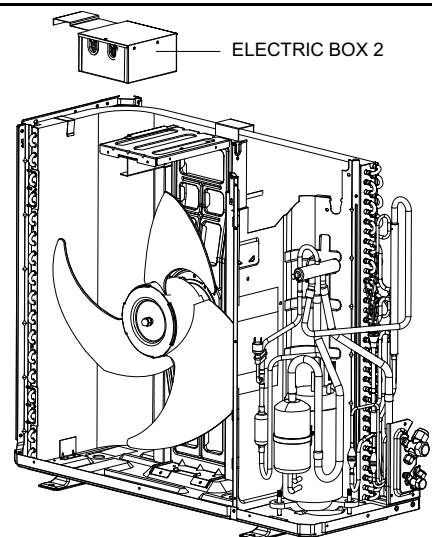

7. Remove left-side plate

- * Remove screws securing the left-side plate with the chassis.
- * Remove left-side plate.

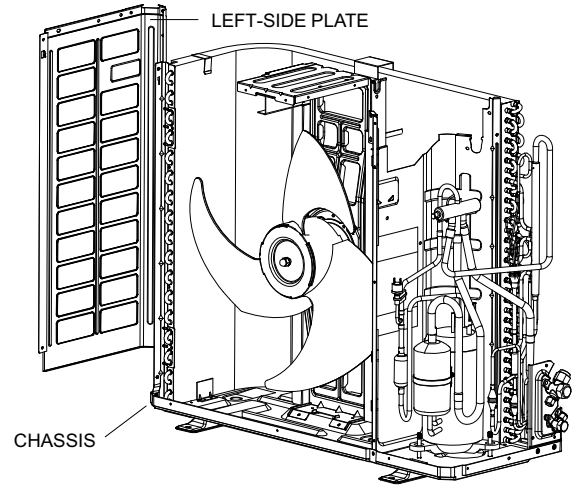

8. Remove axial flow blade

Remove the nut that secures the fan blade to the fan motor shaft. Remove fan blade.

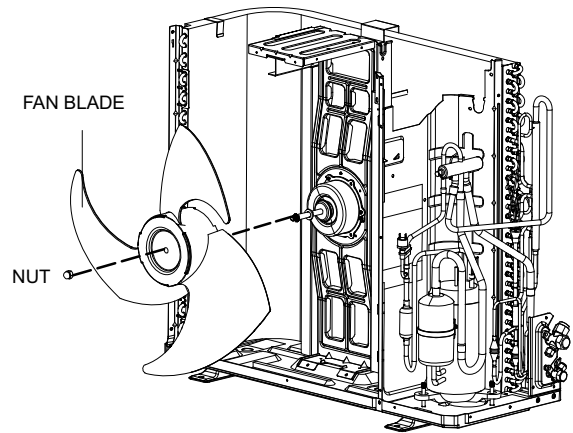

9. Remove motor and motor support

- A
- * Disconnect fan motor wiring harness.
 - * Remove screws that secure the fan motor to the fan motor support.
 - * Remove motor.

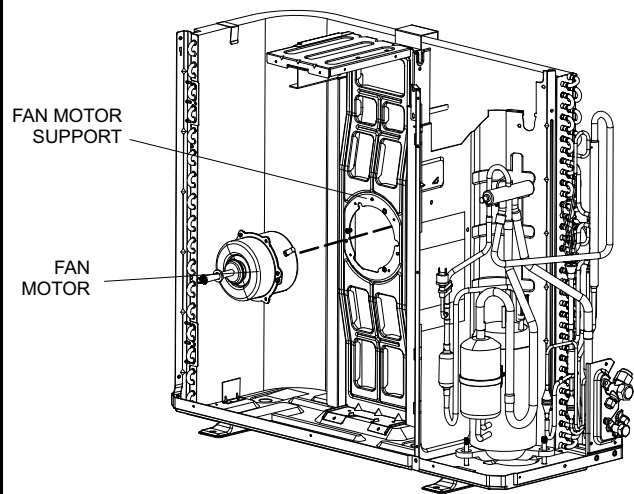

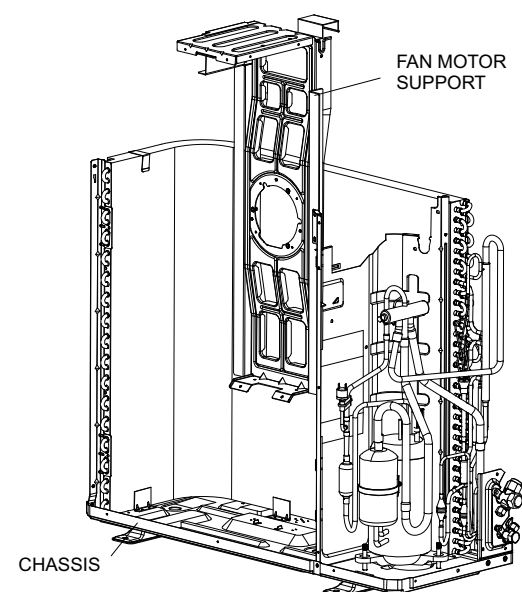
<p>B</p>	<ul style="list-style-type: none"> * Remove screws that secure the fan motor support to the chassis. * To remove, pull assembly upwards. 	 <p>FAN MOTOR SUPPORT</p> <p>CHASSIS</p>
----------	--	--

10. Remove Reversing Valve

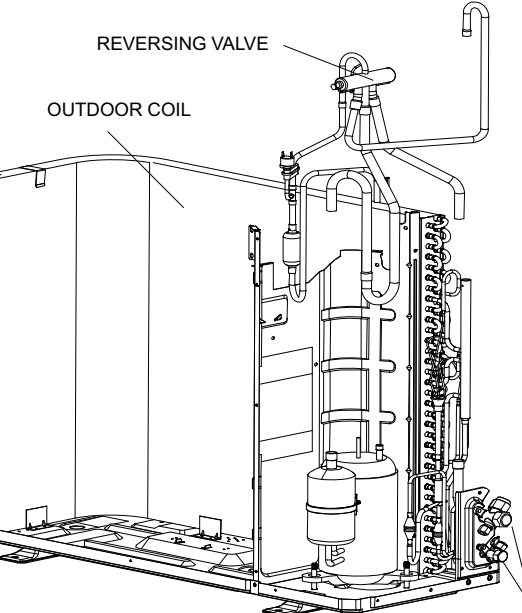
	<p>De-braze the piping between the following components:</p> <ul style="list-style-type: none"> * Compressor * Outdoor coil * 2-way and 3-way valves <p>Remove reversing valve.</p>	 <p>REVERSING VALVE</p> <p>OUTDOOR COIL</p> <p>3-WAY VALVE</p>
--	--	---

11. Remove 2-Way Shutoff and 3-way Service Valves

- * Remove bolts securing the valve assembly.
- * De-braze joint between 3-way service valve and air-return pipe and remove valve.
- * De-braze solder joint between 2-way shut-off valve and connection pipe of valve and remove valve.

IMPORTANT — Wrap both valves with water saturated cloths before de-brazing valves. Water saturated cloths must remain water saturated throughout the de-brazing and cool-down process.

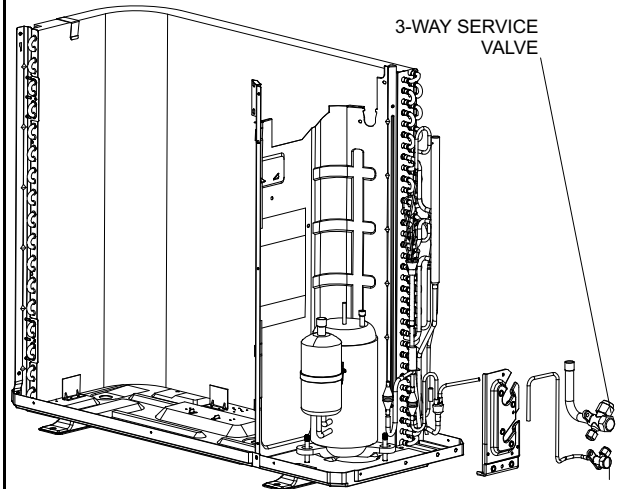

12. Remove Compressor Assembly

- * Remove the three bolts at the base of the compressor assembly (compressor and accumulator).
- * Remove compressor assembly.

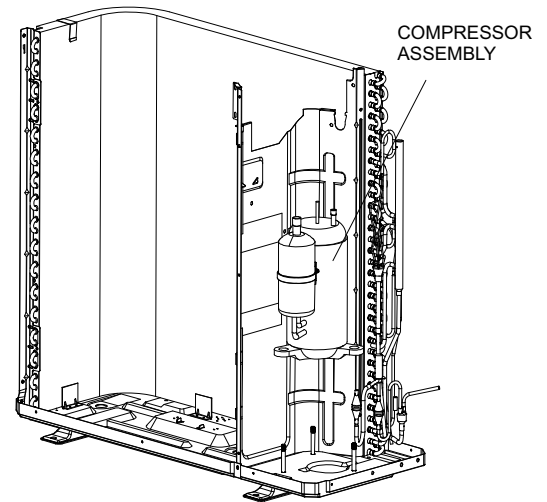

13. Remove Isolation Sheet

- * Remove screws securing the isolation sheet and end plate of the coil and chassis.
- * Remove isolation sheet.

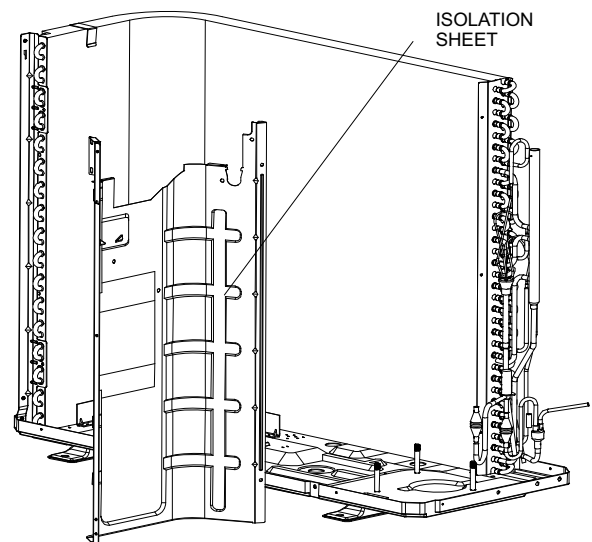

14. Remove Coil Support Plate.

- * Remove screws securing the support plate to the coil.
- * Remove support plate.

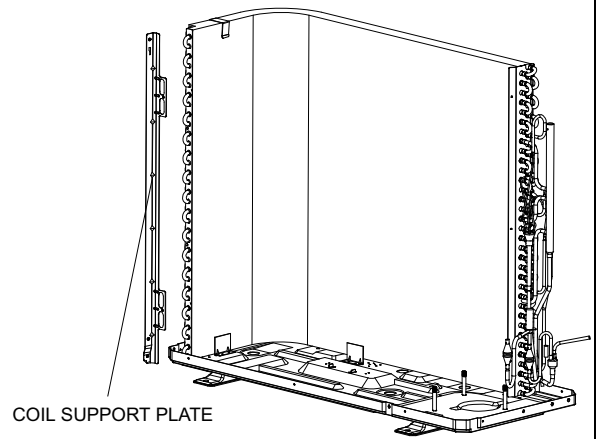

15. Remove Chassis and Coil

Pull coil upwards to separate from the chassis.

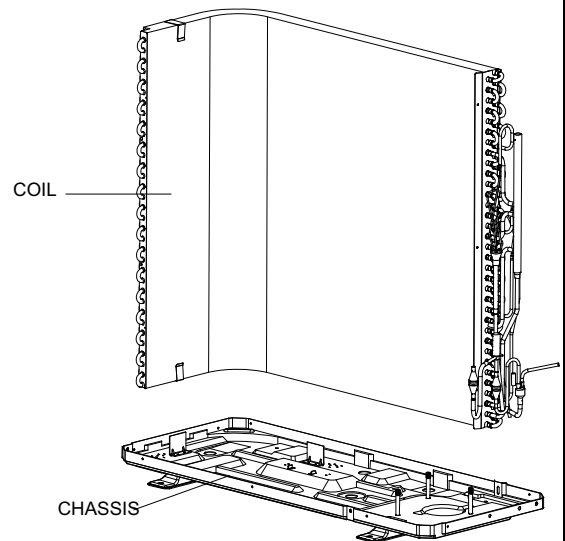

Product View and Part Replacement

MS8-CI-09-L1A, MS8-HI-09-L1A, MS8-CI-12-L1A AND MS8-HI-12-L1A PARTS

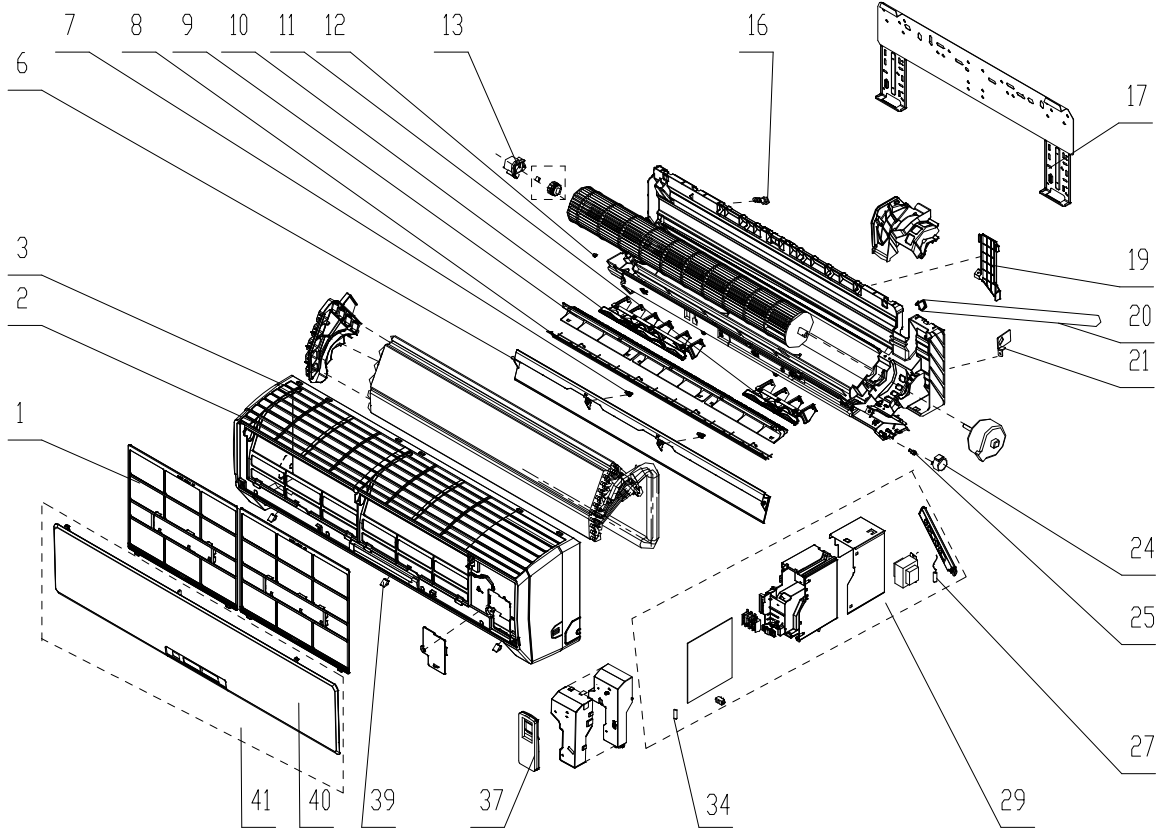

MS8-CI-09-L1A, MS8-HI-09-L1A, MS8-CI-12-L1A AND MS8-HI-12-L1A PARTS

Item	Parts Nomenclature	Catalog Number	Part Number
1	Filter sub-assembly (2 per unit)	Y4041	1112220403
2	Front case sub-assembly	Y4044	2001213914
3	Front case	Y4026	2001212303
4	Evaporator	Y5433	01002574
5	Evaporator Support	Y5459	24212091
6	Guide louver	Y3956	10512157
7	Axile bush	Y3965	10542008
8	Rear Grill	Y3901	1472013
9	Helcoïd tongue (grille)	Y4080	26112163C
10	Air louver 2	Y3958	10512165
11	Air louver 1	Y3957	10512164
12	Left axial bush	Y3954	10512037
13	Axial bush	Y3965	10542008
14	Bearing ring	Y5460	26152022
15	Blower wheel	Y5124	10352017
16	Rubber plug (water tray drain plug)	Y4015	76712012
17	Wall mounting frame	Y3888	01252021
18	Motor mount case	Y5464	26112161
19	Pipe clamp	Y3993	26112164
20	Drainage hose	Y4038	0523001401
21	Cable cross plate (main power conduit plate)	Y3920	02122019
22	Rear case sub-assembly	Y5462	2220210309
23	Fan motor	Y5434	1501208902
24	Step motor (discharge louver motor)	Y4024	1521212901
25	Crank (damper gear)	Y3970	10582070

Item	Parts Nomenclature	Catalog Number	Part Number
27	Indoor ambient temperature sensor	Y4033	390000451
29	Electric box assembly (Cooling unit only) - MS8-CI-09-L1A	Y4052	2020212857
	Electric box assembly (Cooling unit only) - MS8-CI-12-L1A	Y4054	2020212859
	Electric box assembly (Heat pump unit only) - MS8-HI-09-L1A	Y4053	2020212858
	Electric box assembly (Heat pump unit only) - MS8-HI-12-L1A	Y4055	2020212860
34	Tube sensor (indoor coil sensor)	Y4034	390000591G
37	Remote control (iFeel)	Y4001	305100482_K60385
39	Screw covers (plastic screws covers)	Y3990	24252016
40	Front panel	Y4077	27222153021
41	Front panel sub-assembly	Y3980	20012557_K60385

MS8-CO-09-L1A PARTS

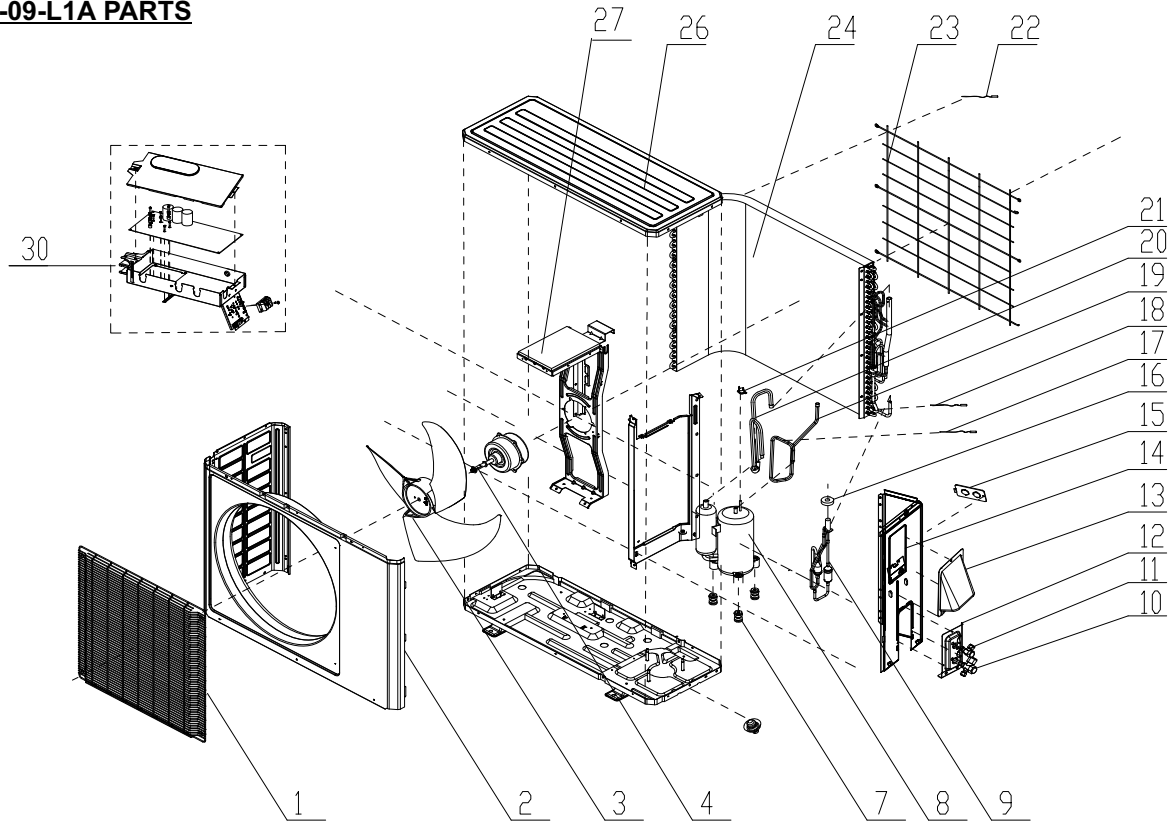

MS8-CO-09-L1A PARTS

Item	Parts Nomenclature	Part Catalog #	Part Number
1	Front grille (fan discharge)	Y3905	01473012
2	Cabinet (discharge panel)	Y4071	0143304601P
3	Axial flow fan	Y3951	10333502
4	Fan motor	Y3975	15013069
7	Compressor gasket (grommets)	Y4016	76815203
8	Compressor and fittings	Y3880	00205212
9	Electric expansion valve sub-assembly	Y3949	07133165
10	Valve (2-way shut off service valve)	Y3940	07100003
11	Valve (vapor 3-way suction/vapor service valve)	Y3941	07100005
12	Valve Support sub-assembly (mounting plate)	Y3915	01713041
13	Cable cross plates sub-assembly (electrical cover)	Y3921	02123015
14	Right side plate (cabinet panel/elect/valves)	Y3974	013030713
15	Cover of pass wire (electric power cover)	Y3896	01413069
16	Magnetic coil (electric expansion valve)	Y4061	4300876701
17	Discharge sensor (compressor)	Y4006	39000016G
18	Tube sensor (outdoor coil sensor)	Y4035	390001921
19	Discharge tube	Y3930	3713494
20	Suction line tubing	Y3929	03523596
21	Overload protector (for the compressor)	Y3879	00180002
22	Temperature sensor (outdoor ambient)	Y4056	3900020801
23	Rear Grille (outdoor coil end)	Y3906	01473014
24	Condenser assembly (outdoor coil)	Y4019	01113405
26	Top (cabinet)	Y3891	01253443
27	Condenser support plate	Y4025	0170300701
30	Electric box assembly	Y4023	0140398653

MS8-CO-12-L1A PARTS

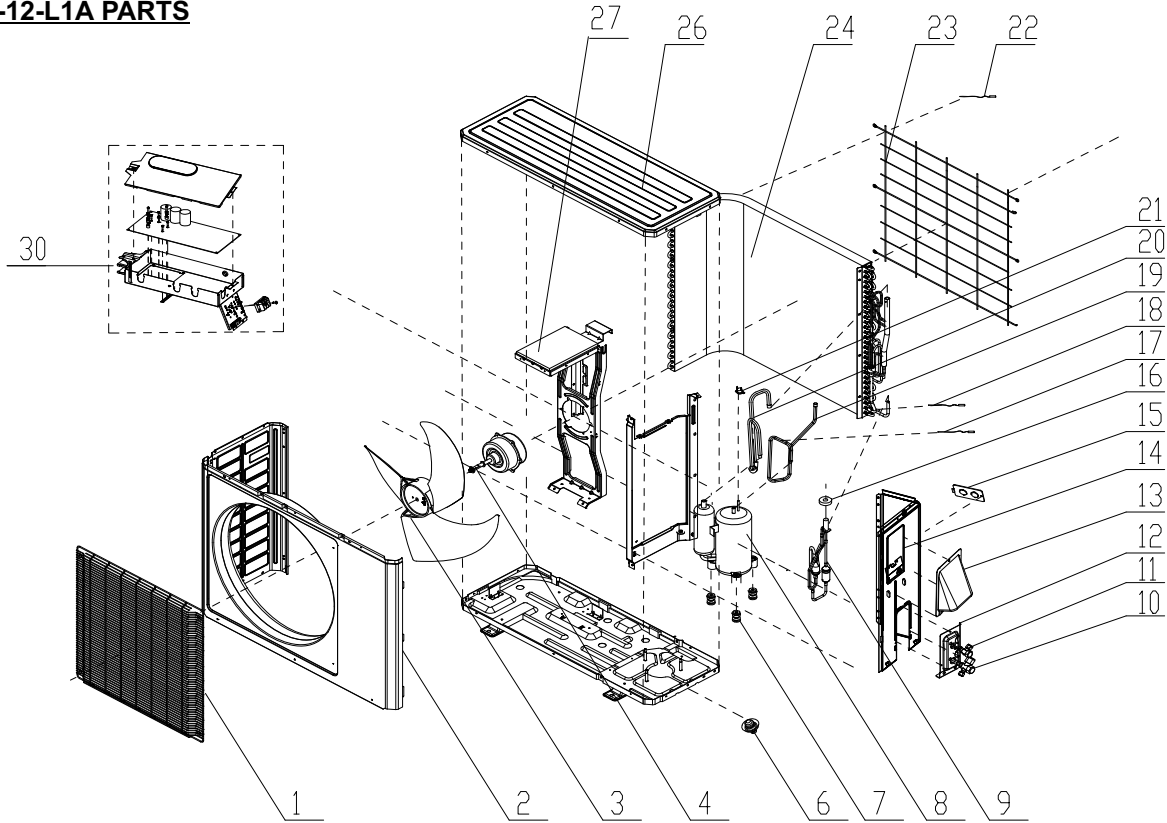

MS8-CO-12-L1A PARTS

Item	Parts Nomenclature	Part Catalog #	Part Number
1	Front grille (fan discharge)	Y3905	01473012
2	Cabinet (discharge panel)	Y4071	0143304601P
3	Axial flow fan	Y3951	10333502
4	Fan motor	Y3975	15013069
7	Compressor gasket (grommets)	Y4016	76815203
8	Compressor and fittings	Y3880	00205212
9	Electric expansion valve sub-assembly	Y3949	07133165
10	Valve (2-way shut off service valve)	Y3940	07100003
11	Valve (vapor 3-way suction/vapor service valve)	Y3941	07100005
12	Valve Support sub-assembly (mounting plate)	Y3915	01713041
13	Cable cross plates sub-assembly (electrical cover)	Y3921	02123015
14	Right side plate (cabinet panel/elect/valves)	Y3974	013030713
15	Cover of pass wire (electric power cover)	Y3896	01413069
16	Magnetic coil (electric expansion valve)	Y4061	4300876701
17	Discharge sensor (compressor)	Y4006	39000016G
18	Tube sensor (outdoor coil sensor)	Y4035	390001921
19	Discharge line tube	Y3931	03713495
20	Suction line tubing	Y3929	03523596
21	Overload protector (for the compressor)	Y3879	00180002
22	Temperature sensor (outdoor ambient)	Y4056	3900020801
23	Rear Grille (outdoor coil end)	Y3906	01473014
24	Condenser assembly (outdoor coil)	Y4017	0111329801
26	Top (cabinet)	Y3891	01253443
27	Condenser support plate	Y3911	0170300701
30	Electric box assembly	Y4023	0140398653

MS8-HO-09-L1A PARTS

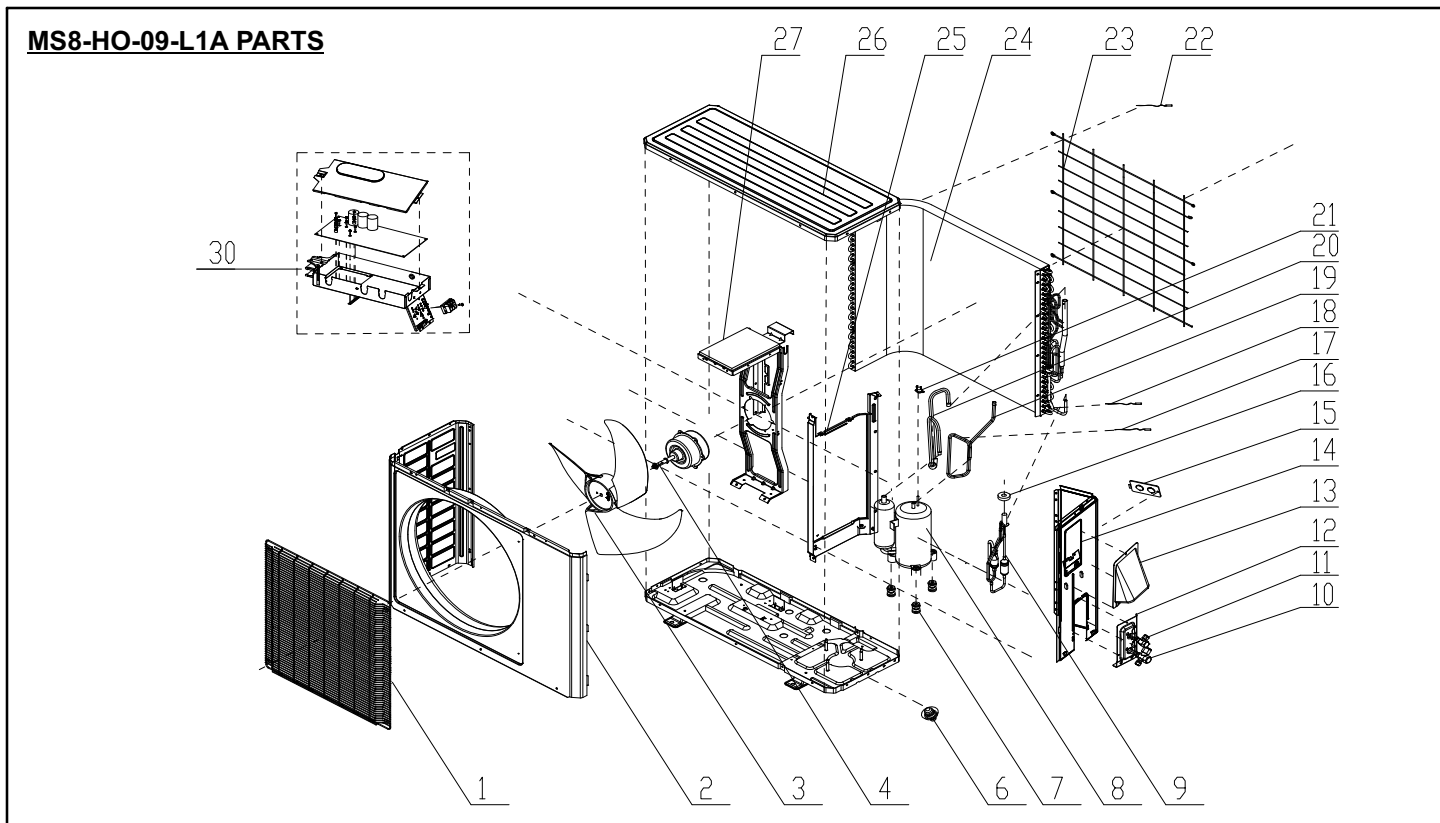

MS8-HO-09-L1A PARTS

Item	Parts Nomenclature	Part Catalog #	Part Number
1	Front grille (fan discharge)	Y3905	01473012
2	Cabinet (fan discharge panel)	Y4071	0143304601P
3	Axial flow fan	Y3951	10333502
4	Fan motor	Y3975	15013069
6	Drain - plug	Y3938	06123401
7	Compressor gasket (grommets)	Y4016	76815203
8	Compressor and fittings	Y3880	00205212
9	Electric expansion valve sub assembly	Y3949	07133165
10	Valve (2-way shut off service valve)	Y3940	07100003
11	Valve (vapor 3-way suction/vapor service valve)	Y3941	07100005
12	Valve support sub-assembly (mounting plate)	Y3915	01713041
13	Cable cross plate sub-assembly (electrical cover)	Y3921	02123015
14	Right side plate (cabinet panel/elect/valves)	Y3974	013030713
15	Cover of pass wire (electric power cover)	Y3896	01413069
16	Magnetic coil (electric expansion valve)	Y4061	4300876701
17	Discharge sensor (Compressor)	Y4006	39000016G
18	Tube sensor (outdoor coil sensor)	Y4035	390001921
19	4-way reversing valve	Y3924	03023794
20	Magnetic coil (reversing valve)	Y4058	4300040021
21	Overload protector (for the compressor)	Y3879	00180002
22	Temperature sensor (outdoor ambient)	Y4056	3900020801
23	Rear grille (outdoor coil end)	Y3906	01473014
24	Condenser assembly (outdoor coil)	Y3883	01113405
26	Top (cabinet)	Y3891	01253443
27	Condenser support plate (outdoor coil and fan mount)	Y3911	0170300701
30	Electric box assembly	Y4022	0140398651

MS8-HO-12-L1A PARTS

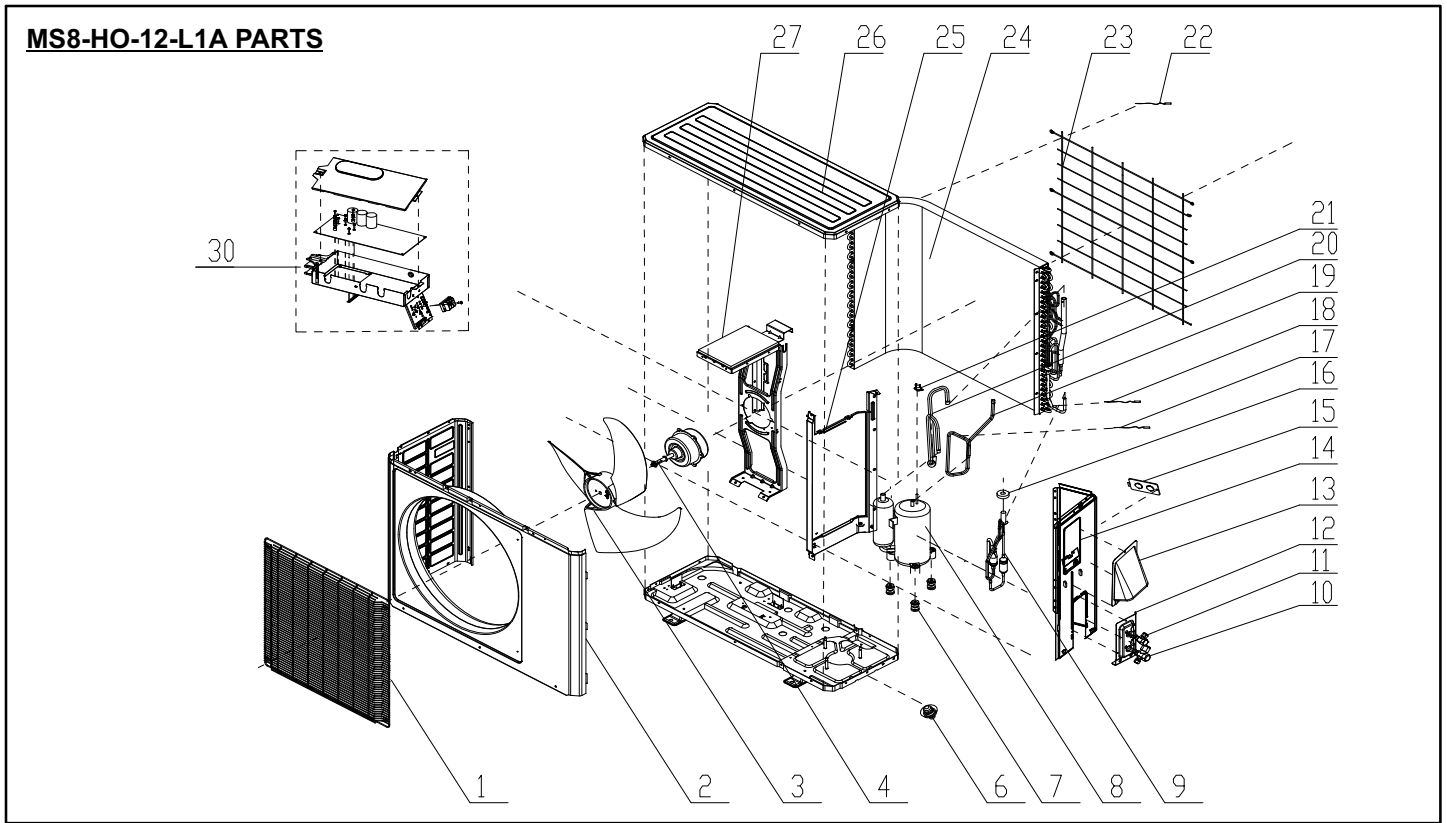

MS8-HO-12-L1A PARTS

Item	Parts Nomenclature	Part Catalog #	Part Number
1	Front grille (fan discharge)	Y3905	01473012
2	Cabinet (fan discharge panel)	Y4071	0143304601P
3	Axial flow fan	Y3951	10333502
4	Fan motor	Y3975	15013069
6	Drain - plug	Y3938	06123401
7	Compressor gasket (grommets)	Y4016	76815203
8	Compressor and fittings	Y3880	00205212
9	Electric expansion valve sub assembly	Y3949	07133165
10	Valve (2-way shut off service valve)	Y3940	07100003
11	Valve (vapor 3-way suction/vapor service valve)	Y3941	07100005
12	Valve support sub-assembly (mounting plate)	Y3915	01713041
13	Cable cross plate sub-assembly (electrical cover)	Y3921	02123015
14	Right side plate (cabinet panel/elect/valves)	Y3974	013030713
15	Cover of pass wire (electric power cover)	Y3896	01413069
16	Magnetic coil (electric expansion valve)	Y4061	4300876701
17	Discharge sensor (Compressor)	Y4006	39000016G
18	Tube sensor (outdoor coil sensor)	Y4035	390001921
19	4-way reversing valve	Y3927	03123315
20	Magnetic coil (reversing valve)	Y4058	4300040021
21	Overload protector (for the compressor)	Y3879	00180002
22	Temperature sensor (outdoor ambient)	Y4056	3900020801
23	Rear grille (outdoor coil end)	Y3906	01473014
24	Condenser assembly (outdoor coil)	Y3881	01113405
26	Top (cabinet)	Y3891	01253443
27	Condenser support plate (outdoor coil and fan mount)	Y3911	0170300701
30	Electric box assembly	Y4022	0140398651