



# CANADIAN FLEXIBLE GAS PIPING DESIGN GUIDE & INSTALLATION INSTRUCTIONS

November  
2011

**TracPipe**<sup>®</sup>  
*Flexible Gas Piping by OmegaFlex*



**CounterStrike**<sup>®</sup>  
*For Enhanced Lightning Protection by TracPipe*

**RESIDENTIAL • COMMERCIAL • INDUSTRIAL**



**TracPipe**  
Flexible Gas Piping  
By Omega Fire

ISO 9001 CERTIFIED



**AutoFlare**

AutoFlare Fittings  
1/2" - 3/4" NPT  
1/2" - 3/4" O.D.  
1/2" - 3/4" I.D.  
1/2" - 3/4" O.D. x 1/2" I.D.  
1/2" - 3/4" O.D. x 3/4" I.D.  
1/2" - 3/4" O.D. x 1" I.D.

# TABLE OF CONTENTS

Chapter 1	Introduction	
1.0	User Warnings	3
1.1	Applicable Codes and Standards Listing	4
	<b>TracPipe</b> ® Specification Data Sheet	5
Chapter 2	Description of System and Components	
2.0	Tubing	6
	Fittings	6
	Accessories	6
	Manifolds	6
	Pressure Regulators	6
	Protection Devices	6
	Shut-off valves	7
2.1	Material Use and Limitations	7
2.2	System Components	9
	<b>TracPipe</b> ® Flexible Gas Piping	9
	<b>AutoFlare</b> ® Fittings	10
	<b>TracPipe</b> ® Accessories	11-12
Chapter 3	System configurations and Sizing	
3.1	System configurations	13
3.1A	Low-Pressure Systems-Series and Parallel	13
3.1B	Dual Pressure Systems	13
3.1C	System Design	14
3.1D	System Pressure Choices	14
3.2	Sizing Methods and Examples	15
3.2A	Use of Sizing Tables	15
3.2B	Sizing Examples Longest Length Method	15
	Example: 1 Low-Pressure System-Series Arrangement	15
	Example: 2 Medium Pressure Systems	16
	Example: 3 Elevated Pressure Systems-Parallel Arrangement	17
	Example: 4 Medium Pressure Systems-Parallel with Branch	18
3.2C	Sizing Hybrid Systems (Combination Black Iron and <b>TracPipe</b> ® Systems)	19
	Example: 5 Low-Pressure Hybrid Systems-Series Arrangement	19
	Example: 6 Low-Pressure System-Series Arrangement	20
3.2D	Alternate Sizing Method (Sum of Pressure Loss Calculations)	21
	Example: 7 Low-Pressure System-Series Arrangement	21
	Example: 8 Low-Pressure Hybrid System-Series Arrangement	22
Chapter 4	Installation Practices	
4.1	General Installation Practices	25
	Minimum Bend Radius	25
	Debris Protection	25
	Support- Vertical Runs/ Horizontal Runs	26
4.2	How to Assemble <b>TracPipe</b> ® AutoFlare Fittings	27
	Tubing Cutting/End Preparation	27
	Assembly Procedure	28
	Minimum Tightening Torque	28
4.2A	Trouble Shooting Fitting Connections	29
	Re-assembly Procedure	29
4.3	Routing	29
	Clearance Holes and Notching	30
4.3A	Concealed Locations for Fittings	30
4.3B	Outdoor Installation Issues	31
4.4	Protection	32
4.4A	Striker Plate Requirements	32
	Spiral Metal Hose Requirements	33
	Thru-penetration Fire Stop UL Classifications	34
4.5	Meter Connections	35
	Termination Mounts/Meter Mounts	35
	Direct Connection	35
4.6	CSST Connection to Outdoor Propane Tanks	36
4.7	Appliance Connections	37
	Moveable Appliances	37
	Fixed Appliance Connections	37
	Termination Fittings with Appliance Connectors	37
	Recessed Wall Box Installation Instructions	38
	Direct Connections	39
4.7A	Pad Mounted Equipment, Roof Top Equipment	40
4.7B	Outdoor Appliances, Barbecue Grill and Gas Light Connections	41
4.7C	Fireplace Installations	42
4.8	Manifold and Regulator Stations	43
4.8A	Regulators and Elevated Pressure Systems	44

	Installation Requirements .....	44
	Vent Limiter Option, Vent Line and Sizing Requirements .....	44
4.8B	Regulator Adjustments .....	44
4.8C	Regulator Supply Pressure and Capacities Drop for Single and Multiple Appliances .....	45
	Capacities Table .....	45
4.8D	Over-Pressure Protection .....	46
4.9	Underground Installations .....	46
4.9A	Guidelines for Underground Installations .....	47
4.9B	<b>TracPipe® PS-II</b> .....	49
4.9C	<b>TracPipe® PS-II</b> Fitting Attachment Instructions .....	50
4.10	Electrical Bonding/Grounding .....	52
4.10A	<b>TracPipe® CounterStrike®</b> CSST Installation Instructions .....	52
4.10B	Bonding Conventional Yellow-Jacketed <b>TracPipe®</b> .....	53
Chapter 5	Inspection, Repair and Replacement	
5.1	Minimum Inspection Requirements (Checklist) .....	55
5.2	Repair/Replacement of Damaged Tubing .....	56
Chapter 6	Pressure/Leakage Testing	
6.0	Pressure Test Procedure .....	57
6.1	Pressure Test for Elevated Pressure Systems .....	57
6.1A	Appliance Connection Leakage Check Procedure .....	58
6.1B	Regulator Performance .....	58
Chapter 7	Capacity Tables .....	59
7.0	Sizing Tables for <b>TracPipe®</b>	
	Table: N-1 Low Pressure (Standard) .....	60
	Table: N-2 Medium Pressure (1 inch drop) .....	60
	Table: N-3 Elevated Pressure 2 PSI .....	61
	Table: N-4 Elevated Pressure 5 PSI .....	61
	Table: N-5 Elevated Pressure 20 PSI .....	62
	Table: P-1 Propane Low Pressure (Standard) .....	62
	Table: P-2 Propane Elevated Pressure 2 PSI .....	63
	Table: P-3 Propane Elevated Pressure 20 PSI .....	63
7.1	Pressure Drop per foot Tables for <b>TracPipe®</b> (Natural Gas) .....	64
	Table: PD-1A Pressure Drop per foot for <b>TracPipe®</b> (Natural Gas) 10-675 CFH .....	65
	Table: PD-1A Pressure Drop per foot for <b>TracPipe®</b> (Natural Gas) 700-3700 CFH .....	66
	Table: PD-1A Pressure Drop per foot for <b>TracPipe®</b> (Natural Gas) 3800-40000 CFH .....	67
	Table: PD-2A Pressure Drop per foot for Metallic Pipe (Natural Gas) 10-675 CFH .....	68
	Table: PD-2A Pressure Drop per foot for Metallic Pipe (Natural Gas) 700-3900 CFH .....	69
	Table: PD-2A Pressure Drop per foot for Metallic Pipe (Natural Gas) 4000-15000 CFH .....	70
	Table: PD-2A Pressure Drop per foot for Metallic Pipe (Natural Gas) 16000-45000 CFH .....	71
7.2	Sizing Table for Steel Pipe	
	Table: SP-1 Maximum Capacity of Pipe in Cubic Feet of Gas per Hour .....	72
Chapter 8	Definition of Terminology .....	73
Appendix A	UL Classification .....	75
Appendix B	Manufactured Housing Guidelines .....	78
Appendix C		
C1.1	<b>AUTOTRIP®</b> Low Pressure Excess Flow Valves for Natural Gas and Propane Service .....	82
C1.2	<b>AUTOTRIP®</b> LFD SERIES Excess Flow Valves for Meter and Branch Line/Manifold Applications .....	83
C1.2.1	Application and Selection of <b>AUTOTRIP®</b> LFD SERIES Excess Flow Valves .....	84
	Table: C-1 <b>AUTOTRIP®</b> "LFD" Series Excess Flow Valves Application Data .....	84
C1.2.2	Gas Piping System Sizing with LFD Series Excess Flow Valves .....	85
C1.2.3	Methods of Sizing .....	85
C1.2.4	Sizing Instructions For <b>AUTOTRIP®</b> LFD SERIES EFVs Used With <b>TracPipe®</b> CSST Systems .....	85
C1.2.5	Sizing Instructions For <b>AUTOTRIP®</b> LFD SERIES EFVs Used With Low Press. Steel Pipe Systems .....	86
C1.2.6	LFD Installation Instructions .....	86
C1.3	<b>AUTOTRIP®</b> AFD SERIES Excess Flow Valves for Appliance Connector Inlet Applications .....	87
C1.3.1	Application and Selection of <b>AUTOTRIP®</b> AFD SERIES Excess Flow Valves .....	88
C1.3.2	AFD Installation Instructions .....	89
	Table: C-2 <b>AUTOTRIP®</b> "AFD" Series Appliance Connector Inlet Excess Flow Valves .....	89
C1.4	<b>GASBREAKER®</b> EXCESS Flow Valves .....	90
	<b>AUTOTRIP®</b> "LFD" Series Capacity Charts	
	Table: N-1AT <b>AUTOTRIP®</b> - <b>TracPipe</b> (Low Pressure System) .....	91
	Table: N-3AT <b>AUTOTRIP®</b> - <b>TracPipe</b> (Dual Pressure System) .....	91
	Table: N-5AT <b>AUTOTRIP®</b> - <b>TracPipe</b> (2-PSI System) .....	92
	Table: SP-1AT <b>AUTOTRIP®</b> -Steel Pipe Low Pressure .....	92
	Table: 3-3 Propane <b>AUTOTRIP®</b> "LFD" Series Excess Flow Valves .....	93
	Table: P-1AT <b>AUTOTRIP®</b> (Propane Low Pressure System 11 in w.c.) - <b>TracPipe®</b> .....	93
	Table: C-4 <b>AUTOTRIP®</b> - GasBreaker Equivalency Chart .....	94
	Figure: C-3 Pressure Drop across <b>AUTOTRIP®</b> "LFD" Series EFV at given Flow Rates .....	95

# CHAPTER 1 INTRODUCTION

## **WARNINGS**

### **SECTION 1.0 — USER WARNINGS**

The *TracPipe*® gas piping material (CSST-Corrugated Stainless Steel Tubing) must only be installed by a qualified person who has been trained or otherwise qualified through the *TracPipe*® Gas Piping Installation Program.

Any installer must also meet qualifications in accordance with provincial and/or local requirements as established by the administrative authority which enforces the plumbing or mechanical code where the gas piping is installed.

This document provides general instructions for the design and installation of fuel gas piping systems using gas piping material CSST. The guide must be used in conjunction with federal, provincial and local building codes. **Local codes will take precedence in the event of a conflict between this guide and the local code.**

In the absence of local codes, installation must be in accordance with the current edition of the National Standard of Canada, *Natural Gas and Propane Installation Code, CSA*

*B149.1*. Sound engineering principles and practices must be exercised for the proper design of fuel gas piping systems, in addition to compliance with local codes. The installation instructions and procedures contained in this Design Guide must be strictly followed in order to provide a safe and effective fuel gas piping system or system modification. All installations must pass customary inspections by the local official having authority prior to having the gas service turned on. All requirements of the local natural gas utility or propane supplier must also be met.

Only the components provided or specified by **OMEGAFLEX** as part of the approved piping system are to be used in the installation.

**The use of *TracPipe*® tubing or fittings with tubing or fittings from other flexible gas piping manufacturers is strictly prohibited and may result in serious bodily injury or property damage.**

### **WARNING !**

If this system is used or installed improperly, fire, explosion or asphyxiation may result. The installation instructions and applicable local codes must be strictly followed.



**OMEGAFLEX®**  
451 Creamery Way  
Exton, PA 19341-2509  
610-524-7272 Fax: 610-524-7282

1-800-671-8622 [www.omegaflex.com](http://www.omegaflex.com)

© Copyright Omega Flex Inc. 2011  
OmegaFlex, TracPipe, AutoFlare, CounterStrike, and AutoTrip are registered trademarks of Omega Flex, Inc.

## **SECTION 1.1 - APPLICABLE CODES AND STANDARDS**

MODEL CODES AND STANDARDS LISTING  
CSST AS AN ACCEPTABLE GAS PIPING  
MATERIAL:

- a. ANSI/IAS LC-1 • CSA 6.26 Standard.
- b. CANADA-CSA B149.1 Natural Gas  
and Propane Installation Code.
- c. Factory Mutual “Flexible Piping  
Systems for Flammable Gases”.
- d. UL Through Penetration Firestop  
Systems Classified (See Appendix A).
- e. Tested to Code Requirements per  
ASTM E84 (UL 723).

This Design and Installation Guide has been written in accordance with the most current edition of ANSI LC1 CSA 6.26, Fuel Gas Piping Systems using Corrugated Stainless Steel Tubing (CSST).

***WHILE EVERY EFFORT HAS BEEN MADE TO PREPARE THIS DOCUMENT IN ACCORDANCE WITH THE MODEL CODES IN EFFECT AT IT'S PRINTING, OMEGAFLEX CANNOT GUARANTEE THAT THE LOCAL ADMINISTRATIVE AUTHORITY WILL ACCEPT THE MOST RECENT VERSION OF THESE CODES.***

***THE INSTALLER IS ULTIMATELY RESPONSIBLE TO DETERMINE SUITABILITY AND ACCEPTANCE OF ANY BUILDING COMPONENT, INCLUDING GAS PIPING. OMEGAFLEX ASSUMES NO RESPONSIBILITY FOR MATERIALS OR LABOR FOR INSTALLATIONS MADE WITHOUT PRIOR DETERMINATION OF LOCAL CODE AUTHORITY ACCEPTANCE.***

# TracPipe®

## SPECIFICATION DATA SHEET

### FGP-SS4-CHART

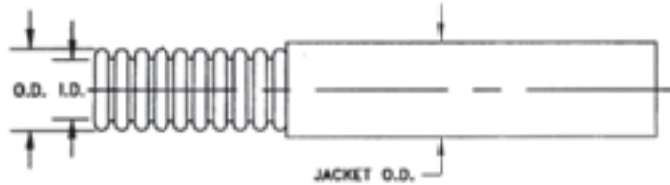

TracPipe® Part No.	FGP-SS4-375	FGP-SS4-500	FGP-SS4-750	FGP-SS4-1000	FGP-SS4-1250	FGP-SS4-1500	FGP-SS4-2000
Size (inch)	3/8"	1/2"	3/4"	1"	1-1/4"	1-1/2"	2"
EHD (AGA size)	15	19	25	31	37	46	62
Jacket O.D. (max.)	.668	.868	1.108	1.383	1.665	1.920	2.590
Inside Diameter (nom)	.440	.597	.820	1.040	1.290	1.525	2.060
Wall Thickness (inch)	.01	.01	.01	.01	.012	.012	.012

\*EHD (Equivalent Hydraulic Diameter) A relative measure of Flow Capacity; This number is used to compare individual sizes between different manufacturers. The higher the EHD number the greater flow capacity of the piping.

### STRAIGHT AUTO-FLARE FITTINGS

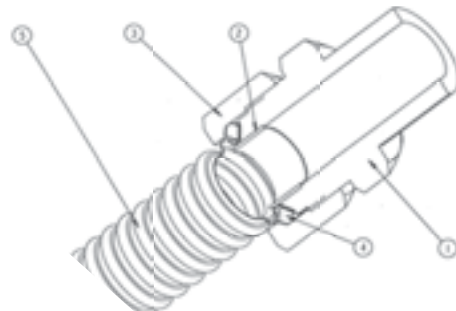

1. ADAPTER – Brass
2. INSERT – Stainless Steel
3. NUT—Brass
4. SPLIT-RINGS – Brass or Stainless Steel
5. FLEXIBLE PIPE – Stainless Steel

AVAILABLE IN SIZES							
Tube size	3/8"	1/2"	3/4"	1"	1-1/4"	1-1/2"	2"
NPT Thread	1/2" or 3/8"	1/2" or 3/4"	3/4" or 1/2"	1" or 3/4"	1-1/4"	1-1/2"	2"

### FLANGE MOUNT AUTO-FLARE FITTINGS

1. ADAPTER – Brass
2. INSERT – Stainless Steel
3. FLANGE NUT – Brass
4. SPLIT-RINGS – Brass or Stainless Steel
5. FLANGE – Malleable Iron/Brass
6. FLEXIBLE PIPE – Stainless Steel

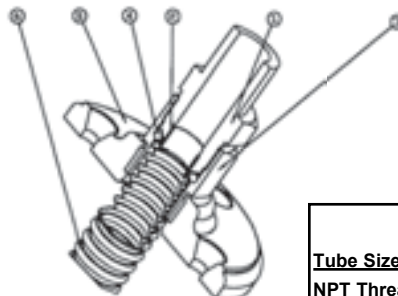

AVAILABLE IN SIZES					
Tube Size	3/8"	1/2"	3/4"	1"	1-1/4"
NPT Thread	1/2" or 3/8"	1/2"	3/4"	1"	1-1/4"

CONSULT FACTORY FOR OTHER TERMINATION METHODS

# CHAPTER 2

## DESCRIPTION of SYSTEM and COMPONENTS

### SECTION 2.0 — *TracPipe*® FLEXIBLE GAS PIPING MATERIAL DESCRIPTION

#### 1. TUBING

The *TracPipe*® fuel gas piping system consists of corrugated, semi-rigid stainless steel tubing with brass mechanical attachment fittings terminating in NPT pipe fittings for easy attachment to traditional black iron pipe systems and direct connections to gas appliances. Tubing is available in sizes 3/8 inch, 1/2 inch 3/4 inch, 1 inch, 1-1/4 inch, 1-1/2 inch, and 2 inch. The 300 series stainless steel tubing is jacketed with a non-metallic cover which provides ease of running through joists, studs, and other building components. The jacket is marked at intervals with the amount of tubing left on the reel, for quick measurement.



#### 2. FITTINGS

Straight NPT pipe fittings are standard and are available in sizes shown above to fit all tubing. Additional fittings include termination mount and flange-mount straight and 90 degree elbow fittings for termination of gas lines near movable appliances; and meter termination accessories for support of *TracPipe*® at utility meter sets on building exteriors and roof penetrations. Tee fittings are available for addition of branch lines into tubing runs; reducer tees are available in popular sizes and pipe outlet tees terminate in pipe threads on the outlet leg for size changes utilizing available black iron reducer fittings.

#### 3. ACCESSORIES

Accessories are available for expansion of the flexible piping material and additions to existing fuel gas piping systems. These accessories include:

- A. Manifolds — allow parallel installations with “home runs” to each appliance. 1/2 inch female NPT outlets and 3/4 inch and 1/2 inch female NPT



inlets. Large size manifolds are also available for use with commercial size *TracPipe*.

- B. Pressure Regulators: pounds to inches - for use in elevated pressure system installations (over 14 inches water column - one half PSI) to reduce pressure to standard low pressure for appliances.



Regulators are available for use on natural and propane gas.

- C. Protection Devices-for use where flexible piping passes through studs, joists and other building materials and is restricted from moving to avoid nails, screws and other puncture threats. There are five striker plate configurations made from stamped steel and specially hardened to resist penetration from screws and pneumatic nail guns. These are quarter-striker, half striker, three quarter striker, full-striker and 6.5





inch X 17 inch flat plate striker. Spiral wound galvanized steel “floppy” conduit is available for use as additional protection.

- D. Shut-off Valves-for use in elevated pressure installations: 2 PSI up to 5 PSI. (Standard gas-cocks should only be used at appliance stub outs and other low pressure areas of the piping system.) Brass lever-handle ball valves supplied by **OmegaFlex** are rated for 5 PSI use and are available in 1/2 inch and 3/4 inch sizes.



## SECTION 2.1 — MATERIAL USE AND LIMITATIONS

**This Design and Installation Guide has been written in accordance with the most current edition of ANSI LC 1 CSA 6.26, FUEL GAS PIPING SYSTEMS USING CORRUGATED STAINLESS STEEL TUBING (CSST).**

This Design Guide is intended to aid the professional gas pipe installer in the design, installation and testing of flexible fuel gas piping systems for residential, commercial and industrial buildings. It is not possible for this guide to anticipate every variation in construction style, building configuration, appliance requirement, or local restriction. This document will not, therefore, cover every application. The user should either exercise his own engineering judgment on system design and installation, or seek technical input from other qualified sources. Additional information pertaining to gas piping systems is available from your local gas utility or propane supplier. Some of the special usage features of **TracPipe**® gas piping are outlined below:

1. Flexible gas piping is used to provide safe, efficient, timely installation of fuel gas pip-

ing within buildings, residential, commercial, and industrial, or for outdoor connections to appliances that are attached or in close proximity to the building.



2. Flexible gas piping can be routed in most locations where traditional gas piping materials are installed: inside hollow wall cavities, along or through floor joists in basements, on top of the joists in attics, on roof tops or along soffits or in chases outside of buildings. **TracPipe**® gas piping has been tested and is listed by CSA International for both outdoor and indoor use.
3. **TracPipe**® is listed by CSA International for fuel gas use in Canada and is rated for pressures up to 25 PSI. For local gas utility approved use only, **TracPipe**® has been tested for use up to 125 PSI for sizes 3/8 inch up to 1-1/4 inch.
4. In North America, the most common pressure for natural gas is 6-7 inches water column, standard low pressure. Elevated pressures of either 2 PSI or one-half PSI are also available from utilities in most areas for new residential construction. 5 PSI systems are commonly installed in commercial or industrial buildings. Elevated pressures allow the use of smaller diameter piping, while providing for increased loads and longer length runs.
5. Flexible gas piping can be used for natural gas and propane (Liquefied Petroleum gas) and other fuel gases recognized in CAN/CSA B149.1.
6. **TracPipe**® CSST with the yellow polyethylene jacket and CounterStrike with black jacket have been tested by Underwriters Laboratory to ASTM E84 (UL723) Surface Burning Characteristics with flame spread and smoke density ratings meeting the requirements of ANSI/CSA LC-1 for use in air ducts and plenums. It is mandatory, however, to follow fire and building code requirements in all installations.

7. For **TracPipe**<sup>®</sup> installed underground or in solid flooring the tubing must be encased in a duct of polyethylene, or other approved water resistant material. Tubing shall be encased in ducts so that there is free airspace around the tube. Such a duct shall be ventilated. This can be accomplished using pre-sleeved **TracPipe**<sup>®</sup> **PS-II**.
8. Flexible gas piping can be used in conjunction with steel pipe (black iron or galvanized) or copper tubing in either new construction or renovation and replacement piping installations. All **TracPipe**<sup>®</sup> fittings terminate in standard NPT male or female pipe threads to interface with appliances, valves, unions and couplings.
9. For retrofit installations, **TracPipe**<sup>®</sup> can be snaked through hollow wall cavities without major restoration as is typical when running rigid pipe through existing construction. The replacement or addition of gas appliances, fireplaces, and gas logs is greatly facilitated with flexible piping on reels requiring no special tooling or oily threading equipment.
10. **TracPipe**<sup>®</sup> gas piping can be run directly to the shut off valves of most fixed appliances without installing an appliance connector. For moveable appliances such as ranges or dryers, the use of an approved flexible appliance connector is required in most jurisdictions. **TracPipe**<sup>®</sup> cannot be substituted as a connector for this use when the appliance is free to move for cleaning, etc.
11. **TracPipe AutoFlare**<sup>®</sup> fittings have been tested by CSA International and are listed for use in concealed locations. This facilitates installation of the key valves required for gas fireplaces in many jurisdictions. Concealed fittings are also desirable when adding tees for branch runs in series configurations and in other installation situations where locating a **TracPipe**<sup>®</sup> fitting in an accessible location is not practical.



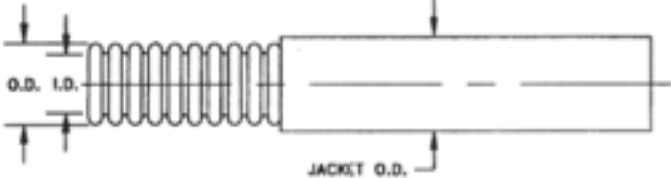

## SECTION 2.2 — SYSTEM COMPONENTS

### TracPipe® Flexible Gas Piping

Component	Material	Description/Dimensions																																								
<p><b>TracPipe®</b> Flexible Gas Piping</p>	<p>Corrugated Stainless Steel (300 Series) with Polyethylene Jacket</p>	<div style="text-align: center;">  </div> <table border="1" data-bbox="625 583 1469 793"> <thead> <tr> <th>Part No.</th> <th>FGP-SS4-375</th> <th>FGP-SS4-500</th> <th>FGP-SS4-750</th> <th>FGP-SS4-1000</th> <th>FGP-SS4-1250</th> <th>FGP-SS4-1500</th> <th>FGP-SS4-2000</th> </tr> </thead> <tbody> <tr> <td>Size (inch)</td> <td>3/8"</td> <td>1/2"</td> <td>3/4"</td> <td>1"</td> <td>1-1/4"</td> <td>1-1/2"</td> <td>2"</td> </tr> <tr> <td>EHD (AGA size)</td> <td>15</td> <td>19</td> <td>25</td> <td>31</td> <td>37</td> <td>46</td> <td>62</td> </tr> <tr> <td>Jacket O.D. (max.)</td> <td>.668</td> <td>.868</td> <td>1.108</td> <td>1.38</td> <td>1.665</td> <td>1.920</td> <td>2.590</td> </tr> <tr> <td>Inside Dia. (nom)</td> <td>.440</td> <td>.597</td> <td>.820</td> <td>1.040</td> <td>1.290</td> <td>1.525</td> <td>2.060</td> </tr> </tbody> </table> <p>*EHD (Equivalent Hydraulic Diameter) A relative measure of Flow Capacity; This number is used to compare individual sizes between different manufacturers. The higher the EHD number the greater flow capacity of the piping.</p>	Part No.	FGP-SS4-375	FGP-SS4-500	FGP-SS4-750	FGP-SS4-1000	FGP-SS4-1250	FGP-SS4-1500	FGP-SS4-2000	Size (inch)	3/8"	1/2"	3/4"	1"	1-1/4"	1-1/2"	2"	EHD (AGA size)	15	19	25	31	37	46	62	Jacket O.D. (max.)	.668	.868	1.108	1.38	1.665	1.920	2.590	Inside Dia. (nom)	.440	.597	.820	1.040	1.290	1.525	2.060
Part No.	FGP-SS4-375	FGP-SS4-500	FGP-SS4-750	FGP-SS4-1000	FGP-SS4-1250	FGP-SS4-1500	FGP-SS4-2000																																			
Size (inch)	3/8"	1/2"	3/4"	1"	1-1/4"	1-1/2"	2"																																			
EHD (AGA size)	15	19	25	31	37	46	62																																			
Jacket O.D. (max.)	.668	.868	1.108	1.38	1.665	1.920	2.590																																			
Inside Dia. (nom)	.440	.597	.820	1.040	1.290	1.525	2.060																																			
<p><b>TracPipe®</b> on Reels</p>	<p>Plywood Reels for Packaging</p>	<div style="text-align: center;">  </div> <p style="text-align: center;"><b>Note: other reel lengths available upon request.</b></p> <table border="1" data-bbox="657 1423 1437 1906"> <thead> <tr> <th>Pipe Size</th> <th>Standard Reel Length</th> <th>Weight Long Reel</th> </tr> </thead> <tbody> <tr> <td>3/8 inch</td> <td>250 feet 100 feet</td> <td>29 pounds</td> </tr> <tr> <td>1/2 inch</td> <td>500 feet 250 feet 100 feet 50 feet</td> <td>87 pounds</td> </tr> <tr> <td>3/4 inch</td> <td>250 feet 100 feet 50 feet</td> <td>55 pounds</td> </tr> <tr> <td>1 inch</td> <td>180 feet 100 feet 50 feet</td> <td>60 pounds</td> </tr> <tr> <td>1-1/4 inch</td> <td>250 feet 150 feet</td> <td>115 pounds</td> </tr> <tr> <td>1-1/2 inch</td> <td>250 feet 150 feet</td> <td>125 pounds</td> </tr> <tr> <td>2 inch</td> <td>150 feet</td> <td>92 pounds</td> </tr> </tbody> </table>	Pipe Size	Standard Reel Length	Weight Long Reel	3/8 inch	250 feet 100 feet	29 pounds	1/2 inch	500 feet 250 feet 100 feet 50 feet	87 pounds	3/4 inch	250 feet 100 feet 50 feet	55 pounds	1 inch	180 feet 100 feet 50 feet	60 pounds	1-1/4 inch	250 feet 150 feet	115 pounds	1-1/2 inch	250 feet 150 feet	125 pounds	2 inch	150 feet	92 pounds																
Pipe Size	Standard Reel Length	Weight Long Reel																																								
3/8 inch	250 feet 100 feet	29 pounds																																								
1/2 inch	500 feet 250 feet 100 feet 50 feet	87 pounds																																								
3/4 inch	250 feet 100 feet 50 feet	55 pounds																																								
1 inch	180 feet 100 feet 50 feet	60 pounds																																								
1-1/4 inch	250 feet 150 feet	115 pounds																																								
1-1/2 inch	250 feet 150 feet	125 pounds																																								
2 inch	150 feet	92 pounds																																								

# AutoFlare® Fittings

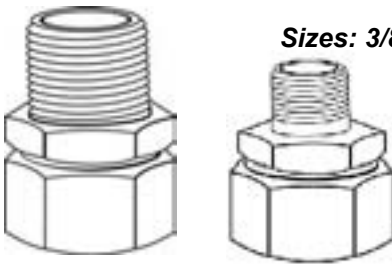
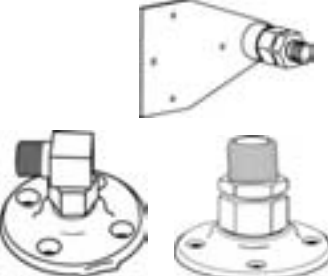
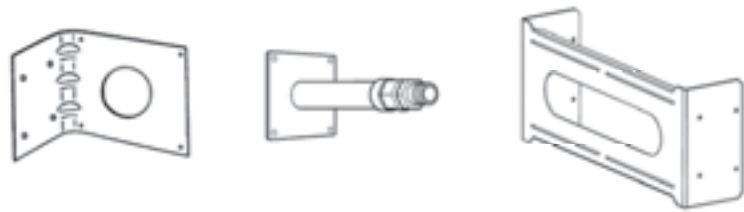
The fittings and accessories pictured on the following pages are representative of the range of products available from **TracPipe®**. Refer to the latest **TracPipe®** Price Sheet for a complete listing of part numbers.

<b>Component</b>	<b>Material</b>	<b>Description/Dimensions</b>
<b>TracPipe® PS-II Accessories</b>		<p style="text-align: center;"><b>PS-II</b></p>  <p style="text-align: center;">Vent Coupling    Nut    Split Rings    Adapter</p>
Straight Mechanical Fitting Reducer Fitting	Brass Fitting  <b>Autoflare® Insert</b>	 <p style="text-align: right;"><b>Sizes: 3/8, 1/2, 3/4, 1, 1-1/4, 1-1/2 and 2 inch</b></p> <p style="text-align: right;"><b>Note size 3/8 fitting has either 1/2 inch NPT or 3/8 inch NPT Thread</b></p>
Termination and Flange Mount Fittings Straight and 90° Elbow	Brass Fitting  <b>Autoflare® Insert</b>  Brass Flange	 <p style="text-align: right;"><b>Sizes: 3/8, 1/2, 3/4, 1 inch and 1-1/4 inch</b></p> <p style="text-align: right;"><b>Note size 3/8 fitting has either 1/2 inch NPT or 3/8 inch NPT Thread</b></p> <p style="text-align: right;"><b>Elbow Sizes: 3/8 inch and 1/2 inch</b></p>
Meter Termination Fitting  Stud Bracket	Brass Fitting <b>Autoflare® Insert</b>  Galv. steel Mounting Bracket	
Flange Mounting Bracket	Galv. Steel	 <p style="text-align: right;"><b>One size fits all: Size 3/8 inch through 1-1/4 inch</b></p>
Tee Fitting & Coupling	Brass Tee Fitting & Coupling <b>Autoflare® Insert</b>	 <p style="text-align: center;"><b>Sizes: 3/8, 1/2, 3/4, 1, 1-1/4, 1-1/2, and 2 inch</b></p> <p style="text-align: center;"><b>Reducer tees available for 1/2, 3/4, 1, 1-1/4, 1-1/2, and 2 inch sizes</b></p>

# TracPipe® Accessories

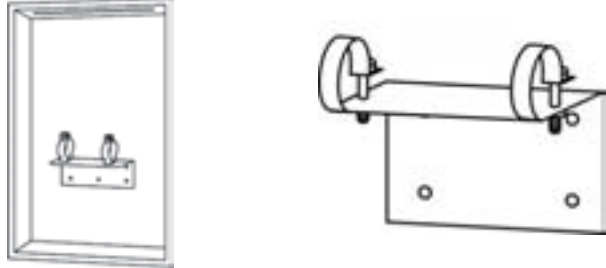
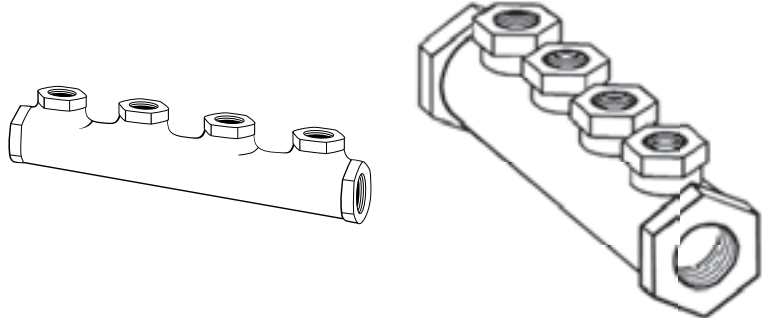
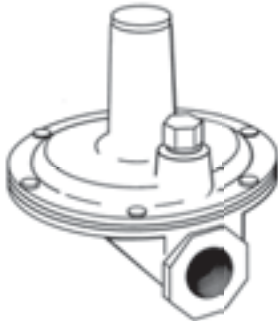
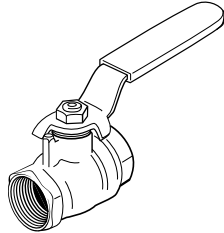
<b>Component</b>	<b>Material</b>	<b>Description/Dimensions</b>
<p style="text-align: center;">Load Center</p> <p style="text-align: center;">Manifold Bracket</p>	<p style="text-align: center;">Painted Steel</p> <p style="text-align: center;">Galvanized Steel</p>	
<p style="text-align: center;">Multi- Port Manifolds</p>	<p style="text-align: center;">Malleable Iron Poly Coated</p>	
<p style="text-align: center;">Pressure Regulators</p>	<p style="text-align: center;">Cast Housing Suitable for Outdoor Use</p>	 <p style="text-align: right;"><b>Sizes: 1/2 inch &amp; 3/4 inch &amp; 1-1/4 inch</b> <b>Regulator includes approved vent limiting device for REG 3 (1/2 inch) and REG 5A (3/4 inch).</b></p> <p style="text-align: right;"><b>Note: Stainless steel High Pressure tags are available for use where required by code</b></p>
<p style="text-align: center;">Shut Off Valves</p>	<p style="text-align: center;">Brass Housing with Stainless Steel Ball</p>	 <p style="text-align: right;"><b>Sizes: 1/2 inch &amp; 3/4 inch</b></p>

# TracPipe® Accessories

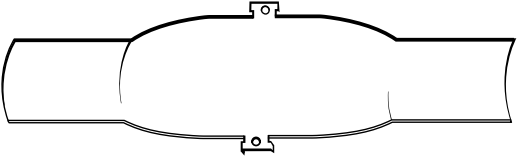
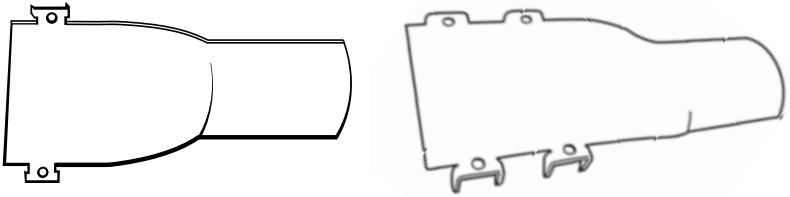
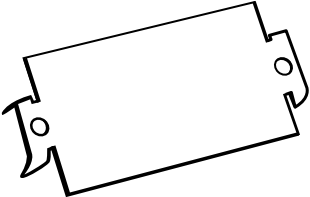
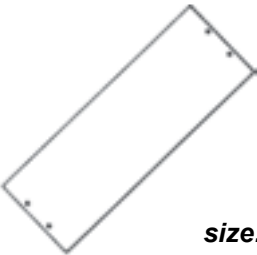
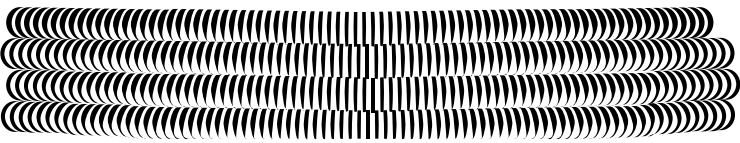
<b>Component</b>	<b>Material</b>	<b>Description/Dimensions</b>
Full Striker Plate	Carbon Steel Hardened	 <p style="text-align: center;"><i>size: 3 inch x 12 inch</i></p>
Half Striker Plate & Three Quarter Striker Plate	Carbon Steel Hardened	 <p style="text-align: center;"><i>size: 3 inch x 7 inch</i>      <i>size: 3 inch x 8 inch</i></p>
Quarter Striker Plate	Carbon Steel Hardened	 <p style="text-align: center;"><i>size: 3 inch x 2 inch</i></p>
6.5 x 17 Striker Plate	Carbon Steel Hardened	 <p style="text-align: center;"><i>size: 6.5 inch x 17 inch</i></p>
Floppy Strip Wound Conduit	Type RW Galvanized Steel	 <p style="text-align: center;"><i>sizes: Fits 3/8, 1/2, 3/4, 1, 1-1/4, 1-1/2 and 2 inch TracPipe</i></p>

# CHAPTER 3

## SYSTEM CONFIGURATIONS AND SIZING

### SECTION 3.1 — SYSTEM CONFIGURATIONS

There are several piping system options available to the installer using *TracPipe*® gas piping material. This flexibility of design is one of the major benefits of CSST.

#### 3.1A — LOW PRESSURE SYSTEMS

1. **SERIES:** A series layout is the most common arrangement utilized for black iron pipe. This consists of a main run with tees branching off to each appliance.

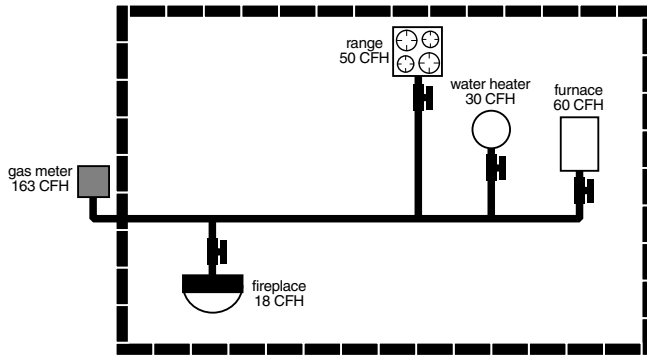

**Series Layout**

2. **PARALLEL:** A parallel system consists of a central distribution manifold with branch runs to the appliances. This is usually accomplished by providing a main supply line to a manifold and installing “home runs” to each appliance location. In the parallel system shown below the pressure is not elevated above 1/2 pound and no regulator is required.

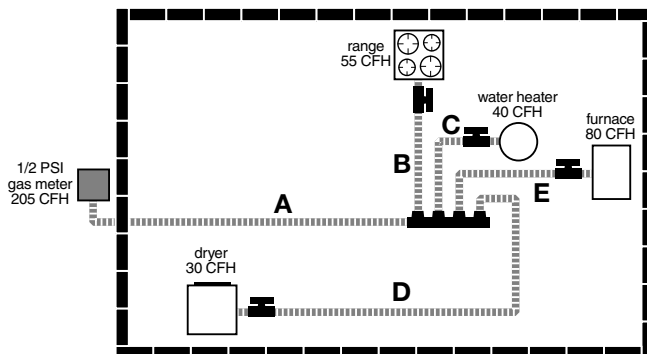

**Parallel Layout**

### 3.1B — DUAL PRESSURE SYSTEMS

Elevated pressure systems (2 PSI for residential and up to 5 PSI for commercial installations) are usually piped with one or more house line regulators (pounds-to-inches) followed by a manifold and runs to each of the appliances. It is possible that these runs to appliances may contain tees branching off to an additional appliance where gas loads permit.

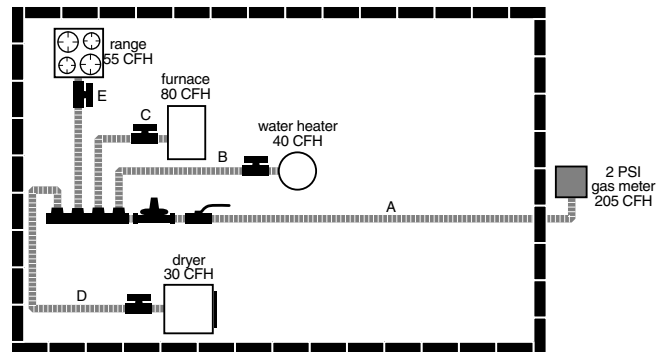

**Dual Pressure System Layout**

**NOTE:**  
**HYBRID SYSTEMS – FLEXIBLE GAS PIPE AND RIGID BLACK PIPE COMBINATIONS.** In low or medium pressure systems, it is often advantageous to use both corrugated stainless steel tubing and rigid pipe in the same system. This is the case when a larger diameter main branch is required to provide for the total appliance load in a parallel system. *TracPipe* is certified for use in combination with black iron pipe and copper tube gas piping systems. For additional information on Hybrid Systems see examples showing the method for sizing hybrid systems using both *TracPipe* and black iron pipe. These are included in the **SIZING EXAMPLES** section of this manual. Refer to Section 3.2C.

## SECTION 3.1C — SYSTEM DESIGN

1. Prepare a sketch or layout of the gas piping system you are about to install. The information you will need is the location of each appliance, the point of delivery (location of utility meter or second stage LP regulator), appliance load demands, and possible pipe routing locations. The load demand data is usually available on the appliance manufacturer's nameplate, or can be provided by the builder.
2. Determine local piping restrictions prior to installing flexible gas piping. The Canadian B149.1 Natural Gas and Propane Installation Code recognizes corrugated stainless steel tubing, but local and province adoption of the most recent edition of this code may lag behind. CONFIRM THAT THE LOCAL CODE AUTHORITY HAS ACCEPTED THE USE OF FLEXIBLE GAS PIPING. Your **TracPipe**® distributor should be able to provide that information but confirmation by the installer should be made where there is a question.

## SECTION 3.1D — SYSTEM PRESSURE CHOICES

1. NATURAL GAS-Determine the delivery pressure provided by the local distribution utility where the piping will be installed.
  - a. LOW PRESSURE-6 to 7 inches water column-equivalent to 4 ounces or 1/4 pound is the standard pressure supplied by natural gas utilities in Canada.
  - b. MEDIUM PRESSURE-1/2 POUND-12 to 14 inches water column-Is available from many natural gas utilities as an enhanced pressure supply. The increase in pressure provides for reductions in pipe size and does not require a pressure regulator. Most natural gas

appliances manufactured for use in Canada are designed to operate up to a maximum of 14 inches water column.

- c. ELEVATED PRESSURE-2-PSI is the highest natural gas pressure usually supplied within single family residential buildings in Canada. This pressure always requires the installation of a pounds-to-inches house line regulator between the utility meter set and the appliances.
2. PROPANE (LP GAS) is typically supplied within residential buildings at 11 inches water column, set at the second stage regulator mounted outside the building. Propane can also be utilized at medium pressure, with the use of a 13-14 inch setting. For 2-PSI propane elevated pressure, the regulator used is FGP-REG-3P (which is factory set at 11 inches water column). A second stage regulator which reduces 10 PSI from the tank to 2 PSI must be used. (e.g. Fisher model R622E or equivalent).

**NOTE:** **TracPipe**® has been tested by CSA International for a working pressure of 125 PSI for sizes 3/8 inch through 1-1/4 inch and 25 PSI for sizes 1-1/2 and 2 inch.

### PRESSURE CONVERSION CHART

1/4 PSI	=	7" w.c.	=	4 oz.
1/2 PSI	=	14" w.c.	=	8 oz.
1 PSI	=	28" w.c.	=	16 oz.
2 PSI	=	56" w.c.	=	32 oz.



# SECTION 3.2 SIZING METHODS and EXAMPLES

## SECTION 3.2A — USE OF SIZING TABLES

This section includes flexible gas piping sizing procedures for both low pressure and elevated pressure systems. Every piping system introduces pressure loss to the fluid flowing within. The amount of loss depends on the piping size and the gas flow, expressed in cubic feet per hour (and converted to BTU's). The object of the sizing exercise is to determine the smallest size piping which will introduce the allowed pressure loss or drop within the length of piping required. Sizing tables (capacity charts) provide the flow capacity for a given length of run for each pipe size. A different sizing table is used for each system pressure and pressure drop combination.

1. The low pressure series system (standard arrangement) is sized in the same way as a conventional low pressure black iron pipe system using **TracPipe**® sizing tables. This method is known as the “Longest Length Method”. Pressure drop in a low pressure system is usually limited to 1/2 inch water column over the system.
2. Elevated pressure systems incorporate two operating pressures downstream of the utility meter set. The first pressure, set by the service regulator at the meter, is usually 2 PSI. This part of the system is sized separately and ends at the pounds-to-inches regulator. The chart in Section 4.8C shows maximum loads through the regulator.
3. For a 2 PSI system, the proper drop is usually 1 PSI for this part of the system; this allows for the approximate inlet pressure into the regulator and provides the 1/4 PSI (6-7 inches w.c.) outlet pressure necessary for appliances. The regulator reduces the pressure from pounds to 8 inches water column. This part of the system is sized the same as a low pressure system. These lines are typically sized for only one appliance load installed as a “home run” from the manifold.

## SECTION 3.2B — SIZING EXAMPLES LONGEST LENGTH METHOD

To size each of the following systems, determine the required size for each section and outlet. To size each section of the system, determine both the total gas load for all appliances and the maximum distance (longest length) in the system.

### EXAMPLE: 1 LOW PRESSURE SYSTEM SERIES ARRANGEMENT

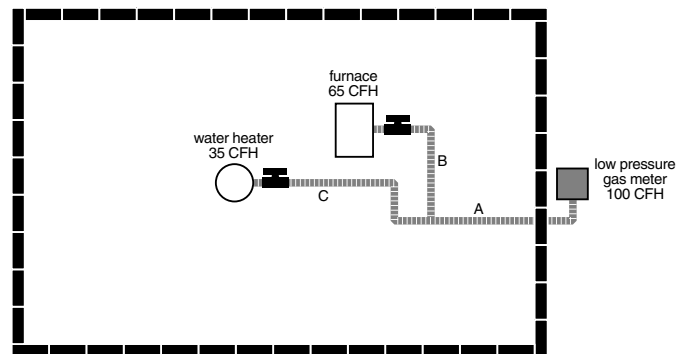
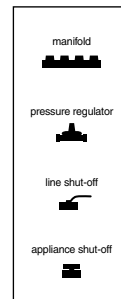

Figure: 3-1



### LENGTH OF RUNS

- A = 10 Feet
- B = 10 Feet
- C = 15 Feet

Supply pressure 6 inches w.c.  
Allowable drop 0.5 inches w.c.

1. The system presented in Figure: 3-1 is typical of a single family installation in which there are a limited number of appliances located in one general area. The supply pressure is 6 inches water column and the allowable drop is 1/2 inch.
2. To size section A, determine the longest run from the meter that includes section A and the total gas load it must deliver:
  - Meter to Furnace is 20 feet (A+B).

- Meter to Water Heater is 25 feet (A+C). This is the longest run.
- Determine the maximum load transported by Section A.
- Furnace plus Water Heater = 100 CFH (100,000 BTU).
- Select Table N-1 “Low Pressure 6 inch- 1/2 inch w.c. drop”.

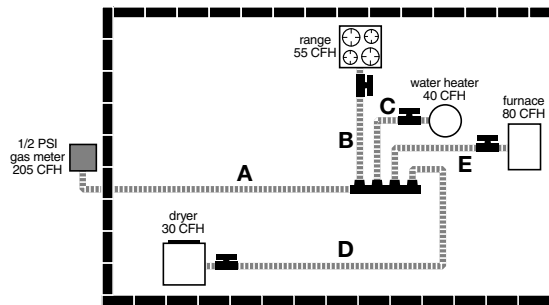

Figure: 3-2

- Using the longest length method, select the column showing the measured length, or the next longest length if the table does not give the exact length. Referring to Table: N-1 the column for 25 feet of piping shows that sizes 3/8 and 1/2 are too small and the next available size is 3/4 supplying 157 CFH.

- The correct size is 3/4 inch.

3. To size Section B, use the same column identified above and the load delivered:

- Length is 25 feet (A+C) and load is 65 CFH (65,000 BTU).
- Table: N-1 shows that size 3/4 inch supplies 157 CFH.
- The correct size is 3/4 inch.

4. To size Section C, use the 25 feet length and determine the required load:

- Length is 25 feet (A+C) and load is 35 CFH (35,000 BTU).
- Table: N-1 shows that size 1/2 inch is required, because size 3/8 inch only supplies 29 CFH (29,000 BTU).
- The correct size is 1/2 inch.

**EXAMPLE: 2 MEDIUM PRESSURE 12-14 INCH W.C. (1/2 PSI)**

1. The system shown in Figure: 3-2 is typical of a single family installation with several appliances. The arrangement chosen is parallel. The MEDIUM PRESSURE SYSTEM (1/2 PSI) allows a higher pressure drop (1 inch water column) than is available with low pressure systems.

**LENGTH OF RUNS**

A = 10 Feet  
 B = 20 Feet  
 C = 10 Feet  
 D = 40 Feet  
 E = 10 Feet

Supply pressure 1/2 PSI  
 (12 inch-14 inch w.c.)  
 Allowable drop: 1 inch w.c.

2. To size SECTION A, determine the LONGEST RUN from the meter to the furthest appliance:

- Meter to Dryer is 50 feet (10+40) A+D.
- Determine maximum load transported by section A.
- Dryer + Range + Water heater + Furnace = 205 CFH (205,000 BTU).

- Select Table: N-2 “Medium Pressure 1/2 PSI with 1 inch drop”. Table: N-2 shows that 3/4 inch size is too small for 205 CFH at 50 feet but 1 inch can handle 267 CFH.
- The correct size is 1 inch.

3. To size SECTION B, the distance remains 50 feet:

- Load is 55 CFH (55,000 BTU).
- Table: N-2 shows that 1/2 inch size can handle 63 CFH.
- The correct size for section B is 1/2 inch.

4. To size SECTION C, the distance is 50 feet:

- Load is 40 CFH (40,000 BTU).
- Table: N-2 shows that 1/2 inch size can handle 63 CFH.
- The correct size for section C is 3/8 inch.

5. To size SECTION D, the distance is 50 feet:

- Load is 30 CFH ( 30,000 BTU).
- Table N-2 shows that 3/8 inch size can handle 29 CFH at 50 feet.
- The correct size for section D is 1/2 inch.

6. To size SECTION E, the distance is 50 feet:

- Load is 80 CFH (80,000 BTU).
- Table: N-2 shows that 3/4 inch size can handle 157 CFH at 20 feet.
- The correct size for section E is 3/4 inch.

**EXAMPLE: 3 ELEVATED PRESSURE 2 PSI SYSTEM- PARALLEL ARRANGEMENT**

1. The system shown in Figure: 3-3 is adapted for multifamily or single family application with an extended (100 feet) tubing run from the

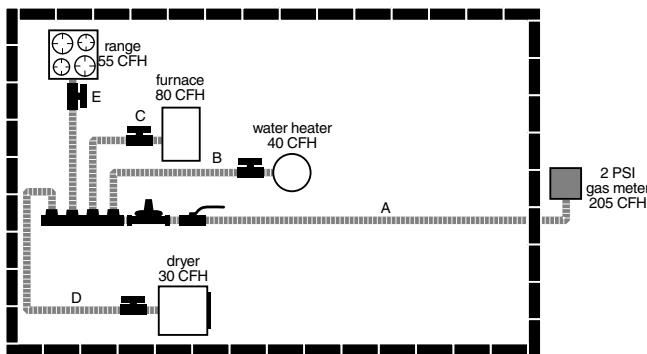
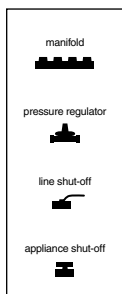

Figure: 3-3



**LENGTH OF RUNS**

- A = 100 Feet
- B = 15 Feet
- C = 10 Feet
- D = 25 Feet
- E = 20 Feet

Supply pressure 2 PSI  
 Allowable drop: 1 PSI up to reg.  
 1 inch w.c.-reg. to appliance

meter to the regulator. The 2 PSI system is well adapted to handle the long runs required in multifamily buildings with centralized meter banks.

2. To size section A determine the entire gas load it will deliver:

- Furnace + Water Heater + Dryer + Range = 80 CFH + 40 CFH + 30 CFH + 55 CFH = 205 CFH(205,000 BTUH) Select Table: N-3 “Elevated Pressure 2 PSI with 1 PSI drop” This is the standard table chosen to stay within the FGP-REG-3 regulator capacity. See note below.

- Length is 100 feet.
- Table: N-3 shows that 3/8 inch size is too small for 205 CFH but 1/2 inch can handle 226 CFH.
- The correct size is 1/2 inch.

3. To size each of the other sections:  
 Select Table: N-2 “Regulator Outlet 8.0 inches w.c with a drop of 1.0 inches w.c:

- Section B is 15 feet with a 40 CFH load 3/8 inch has a capacity of 52 CFH.
- Section C is 10 feet with a 80 CFH load 1/2 inch has a capacity of 138 CFH.
- Section D is 25 feet with a 30 CFH load 3/8 inch has a capacity of 41 CFH.
- Section E is 20 feet with a 55 CFH load 1/2 inch has a capacity of 99 CFH.

**Supply Pressure and Capacities**

Based on flow in cubic feet per hour

P/N	1/2 PSI (34 mbar)	3/4 PSI (52 mbar)	1 PSI (69 mbar)	1-1/2 PSI (103 mbar)
FGP-REG-3	145 (4.1)	200 (5.7)	250 (7.1)	250 (7.1)
FGP-REG-5A	335 (9.5)	475 (13.5)	550 (15.6)	550 (15.6)
FGP-REG-7L	690 (19.5)	970 (27.5)	1000 (28.3)	1000 (28.3)

**EXAMPLE: 4 MEDIUM PRESSURE  
12-14 INCHES W.C. 1/2 PSI) PARALLEL  
SYSTEM WITH A SERIES BRANCH**

1. The system shown in Figure: 3-4 has a barbeque installed nearby the range. A parallel arrangement was chosen for the medium pressure system (12 inch W.C. with 1 inch W.C. drop) with a single run feeding both range and barbecue in series.

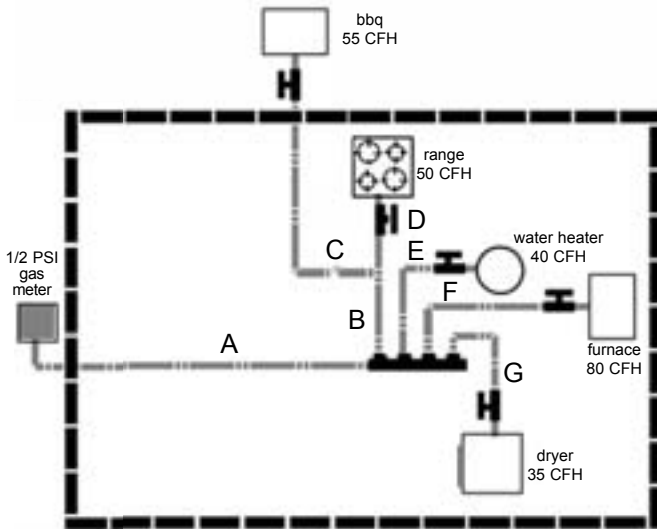

Figure: 3-4

LENGTH OF RUNS

- A = 20 Feet
- B = 35 Feet
- C = 20 Feet
- D = 10 Feet
- E = 10 Feet
- F = 10 Feet
- G = 15 Feet

2. To size SECTION A, determine the length of the longest run from the meter and the entire gas load it must deliver:

- Range + Barbecue + Water Heater + Furnace +Dryer = 260 CFH (260,000 BTUH).
- Meter to Barbecue is 75 feet (A+B+C) This is the longest length.
- Select Table: N-2 Medium Pressure. Table: N-2 shows that 1-1/4 inch is required for 260 CFH at 75 feet.
- The correct size is 1-1/4 inch.

3. To size SECTION B, the line from the manifold serves both the Range and the Barbecue:

- Total load is 105 CFH (105,000 BTUH).
- Longest length is 75 feet (A+B+C) from the meter to the Barbecue.
- Table: N-2 shows that size 3/4 inch can handle 129 CFH at 75 feet.
- The correct size is 3/4 inch.

4. To size SECTION C, the distance from the meter to the barbecue is 75 feet (A+B+C):

- Load is 55 CFH (55,000 BTUH).
- Table: N-2 shows that size 3/4 inch can handle 129 CFH at 80 feet.
- The correct size is 3/4 inch.

5. To size SECTION D, the distance is 75 feet:

- Load is 50 CFH (50,000 BTUH).
- Table: N-2 shows that size 1/2 inch can handle 52 CFH at 75 feet.
- The correct size is 1/2 inch.

6. To size SECTION E, the distance is 75 feet:

- Load is 40 CFH (40,000 BTUH).
- Table: N-2 shows that size 1/2 inch can handle 52 CFH at 30 feet.
- The correct size is 1/2 inch.

7. To size SECTION F, the distance is 75 feet:

- Load is 80 CFH (80,000 BTUH).
- Table: N-2 shows that size 3/4 inch can handle 129 CFH at 30 feet.
- The correct size is 3/4 inch.

8. To size SECTION G, the distance is 75 feet:

- Load is 35 CFH (35,000 BTUH).
- Table: N-2 shows that size 1/2 inch can handle 52 CFH at 40 feet.
- The correct size is 1/2 inch.

## SECTION 3.2C — SIZING HYBRID SYSTEMS (Black Iron and *TracPipe*® Combination)

To size a commercial or a residential system with a rigid black iron trunk line and flexible *TracPipe* branches feeding the appliances, you will need both the standard gas piping capacity tables for black iron printed in the B149 Natural Gas and Propane Installation Code and the *TracPipe* Capacity Tables printed later in this manual.

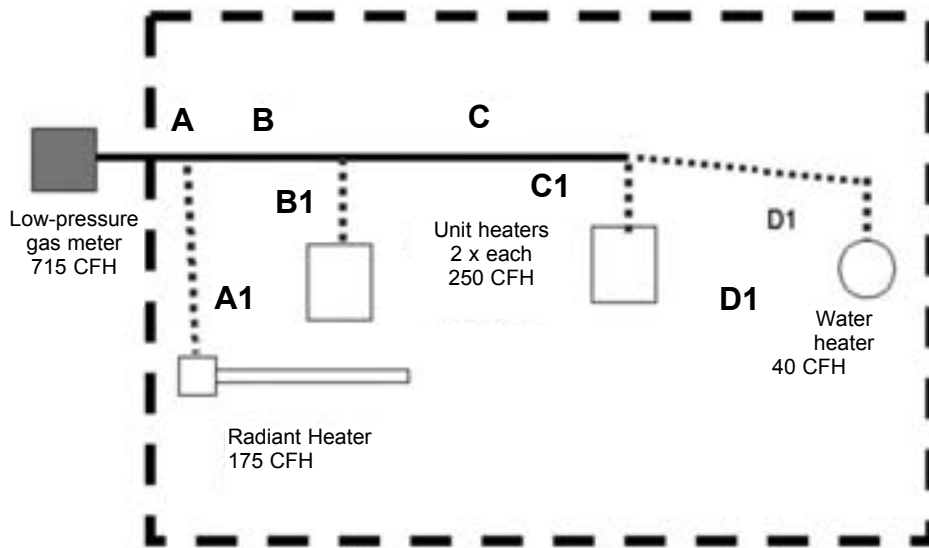

Figure: 3-5

### LENGTH OF RUNS

A = 15 Feet    C = 20 Feet  
A1 = 45 Feet    C1 = 5 Feet  
B = 15 Feet    D1 = 20 Feet  
B1 = 10 Feet

**NOTE:** Black Iron pipe Capacity Table is provided in this Design Guide Section 7.2

### EXAMPLE: 5 LOW PRESSURE HYBRID SYSTEM (Black Iron and *TracPipe* Combination) SERIES ARRANGEMENT

1. The system shown in Figure: 3-5 is a typical commercial building with 4 appliances. The gas pressure for this example is standard low pressure with 6-inch supply pressure and 0.5-inch pressure drop.
2. To determine rigid pipe size (section A) determine the longest run from the meter

to the furthest appliance: Meter to Water Heater add A + B + C + D1 = 70 feet. Total Load is 715 CFH 15,000 BTU). Section A correct size is 2 inch black pipe.

3. To determine rigid pipe size (section B) reduce load by the load carried in section A1 to Radiant Heater (175 CFH). Use same number for length: 70 feet is longest run. Load for this section is 540 CFH Section B correct size is 1-1/2 inch black pipe.

4. To determine rigid pipe size (section C) reduce load further by the load carried in Section B1 to first unit heater (250 CFH). Use same number for length: 70 feet is longest run. Load for this section is 290 CFH. Section C, Correct size is 1-1/4 inch black pipe.

5. To determine *TracPipe* sizing for the branch runs the length to be used is the total length of black pipe plus *TracPipe* from the meter to the furthest appliance. The load used is the load of the individual piece of equipment.

6. To determine the size of *TracPipe* (section D1) the length is 70 feet and the load is 40 CFH. Using Table: N-1 Section D correct size is 3/4 inch.

7. To determine the size of *TracPipe* (section C1) the length is 70 feet and the load is 250 CFH. Using Table: N-1 Section C1 correct size is 1-1/4 inch.

8. To determine the size of *TracPipe* (section B1) the length is 70 feet and the load is 250 CFH. Using Table: N-1 Section B1 correct size is 1-1/4 inch.

- To determine the size of **TracPipe** (section A1) the length is 70 feet and the load is 175 CFH. Using Table: N-1: Section A1 correct size is 1-1/4 inch.

**EXAMPLE: 6 LOW PRESSURE HYBRID SYSTEM (Black Iron and *TracPipe*® Combination) SERIES ARRANGEMENT**

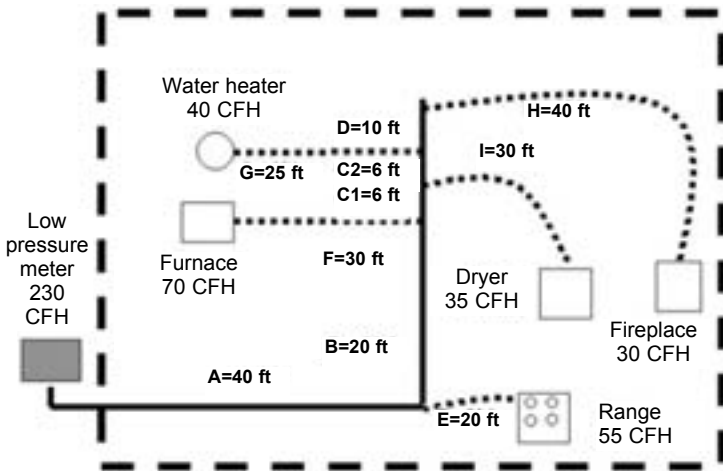

Figure: 3-6

- The system presented in Figure: 3-6 is a typical residence with 5 appliances. The supply pressure is 7 inches w.c. The allowable drop is 1-inch w.c. total.
- The black iron trunk line (A+B+C1+C2+D) will first be sized for a drop of 1.0 inch, w.c. in accordance with the standard method (longest total run) and each **TracPipe** branch run to an appliance will then be sized for 1.0 inch w.c. drop based on the longest total run. The maximum pressure drop to each appliance will be 1.0-inch w.c.
- The longest total run is 122 feet (total length of all black iron sections and **TracPipe** section to the furthest appliance). The total load is 70+40+55+35+30=230 CFH. Correct size for A is 1-1/4 inch.
- Section B, the longest run remains 122 feet but the load is reduced to 175 CFH. Correct size is 1 inch.

- Section C1, the longest run is 122 feet and load is reduced to 105. Correct size is 3/4 inch.
- Section C2, the longest run is 122 feet and load is reduced to 70. Correct size is 3/4 inch.
- Section D, the longest run is 122 feet and load is reduced to 30. Correct size is 1/2 inch.
- Section E, length is 122 feet and the load is 55 CFH. From Table: N-2 the correct size is 3/4 inch.
- Section F, length is 122 feet and the load is 70 CFH. From Table: N-2 the correct size is 3/4 inch.
- Section G, length is 122 feet and the load is 40 CFH. From Table: N-2 the correct size is 1/2 inch.
- Section H, length is 122 feet and the load is 30 CFH. From Table: N-2 the correct size is 1/2 inch.
- Section I, length is 122 feet and the load is 35 CFH. From Table: N-2 the correct size is 1/2 inch.



## SECTION 3.2D — ALTERNATE SIZING METHOD: SUM OF PRESSURE LOSS CALCULATIONS

1. In addition to the longest run sizing method, there is another approach to pipe sizing, which yields results closer to the actual friction loss results (obtained from testing) for each section of an installed gas piping system. This engineered approach “Sum of Pressure Loss Calculations” avoids the simplified, conservative approximations of the longest run method. Mechanical engineers who design piping systems understand that placing a building’s entire load (theoretically) at the farthest equipment outlet is not only inaccurate, but will often yield pipe sizes which are larger than necessary. The longest run method was devised at a time when gas utilities could not always guarantee a constant pressure at every meter during times of high demands; it is a conservative approach and, although it is the customary sizing approach in Canada, other engineered calculations are permitted by the code.
2. Pressure loss calculations which sum up friction losses in each section of a gas piping system can provide a system design with more accurate and possibly smaller piping diameters than the traditional longest run method. These calculations utilize pressure loss charts for each size of CSST, which have been developed from actual test results. The maximum flow capacity is predicted with more precision than with the longest run method. The Sum of Pressure Loss method is described below with tables providing pressure loss per foot based upon the total load supplied by that length of pipe with all appliances operating.
3. The system designer has simply to determine the load and the length for each run. A tentative size is chosen and pressure loss in that leg is determined by multiplying the loss per foot (inches w.c. from

the chart) by the length. Starting at the meter and working outward the pressure loss for each leg is then summed up until the farthest appliance is reached. The total calculated loss is then compared with the allowable loss, which must not be exceeded from the meter to the farthest appliance. The allowable pressure loss for each system is the responsibility of the system designer, based on model codes and on the available pressure at the meter set (or second stage regulator) and the pressure required for each appliance (usually found on the manufacturer’s data plate.) If the initial proposed design calculation yields a total pressure loss, which is higher than allowed, simply go back and calculate again with larger sizes, starting from the meter.

### USING SUM OF PRESSURE LOSS METHOD EXAMPLE: 7 LOW PRESSURE SYSTEM SERIES ARRANGEMENT

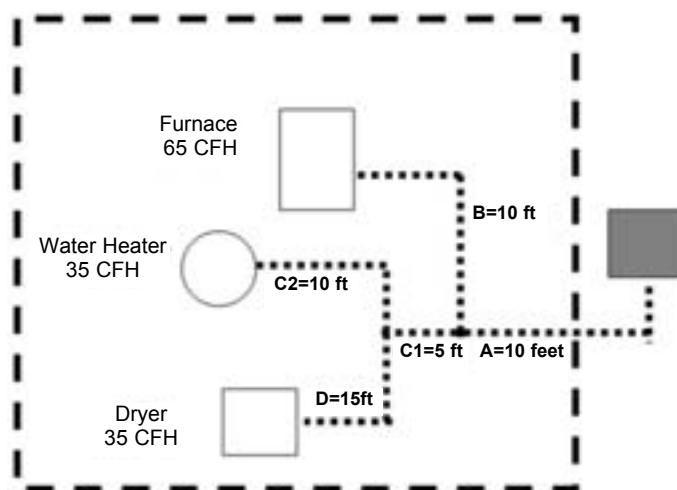

Figure: 3-7

1. The system presented in Figure: 3-7 is similar to that in 3-1, a single-family installation with the addition of one more appliance, a dryer. The supply pressure is 6 inches water column and the allowable pressure drop is 0.5 inch.
2. To size section A, calculate the load carried by that section:
  - Furnace plus Water Heater plus Dryer = 135 CFH (135,000 BTU).
 Using Table: PD-1A find pressure loss at

135 MBTU load through 3/4 inch **TracPipe**<sup>®</sup>  
Average of .0135 and .0158 is .0147. Drop per foot is 0.0147; multiply by length 10 feet = 0.147 drop.

- To size section B find the drop per foot for the load carried by that section:
  - Furnace Load 65 CFH (MBTU).
 Using Table: PD-1A find pressure loss at 65 MBTU through 1/2 inch **TracPipe**<sup>®</sup>. Use the average of loss between 60 and 70 MBTU: Average of .0177 and .0244 is .0211; Drop per foot is 0.0211; Multiply by length 10 feet = 0.211 drop.  
Sum pressure loss meter to Furnace  $0.147 + 0.211 = .358$  inch w.c.  
This leg is sized properly at 1/2 inch because sum of loss is less than .5 in. w.c.

- To size section C1 find the drop per foot for the load carried by that section:
  - 70 CFH (MBTU).
 Using Table: PD-1A find pressure loss at 70 MBTU load through 1/2 inch **TracPipe**<sup>®</sup>. Drop per foot is .0244; length is 5 feet;  $5 \times .0244$  is .122.

- To size section C2 find the drop per foot for the load carried by that section:
  - 35 CFH (MBTU)
 Using Table: PD-1A find pressure loss at 35 CFH load through 1/2 inch **TracPipe**<sup>®</sup>. Average of .0077 and .0042 is .0060; length is 10 feet;  $10 \times .006$  is .06. Sum pressure loss to water heater  $0.147 + .122 + .06 = .329$  inches w.c. This leg is sized properly at 1/2 inch because sum of loss is less than .5 in. w.c.

- To size section D find the drop per foot for the load carried by that section:
  - 35 CFH (MBTU).
 Using Table: PD-1A find pressure loss at 35 MBTU through 1/2 inch **TracPipe**<sup>®</sup>. Drop per foot is .006 (See number 4 above); Multiply by length 15 feet = .09.

Sum pressure loss to dryer  $0.147 + 0.122 + .09 = .359$  inch w.c.

This leg is sized properly at 1/2" because sum of loss is less than .5 in. w.c.

The sum of pressure loss method allows the addition of an appliance without increasing trunk line size.

**EXAMPLE: 8 LOW PRESSURE HYBRID SYSTEM (Steel Pipe and TracPipe Combination) SERIES ARRANGEMENT USING SUM OF PRESSURE LOSS METHOD**

- The system presented in Figure: 3-8 is identical to that in Figure: 3-6, a single-family installation with 5 appliances. Low pressure 6-7 inches and a pressure drop of 0.5 inch water column. **NOTE:** In Example: 6 this system was sized using the longest run method. Here we will use the sum of pressure loss method discussed in section 3.2D.

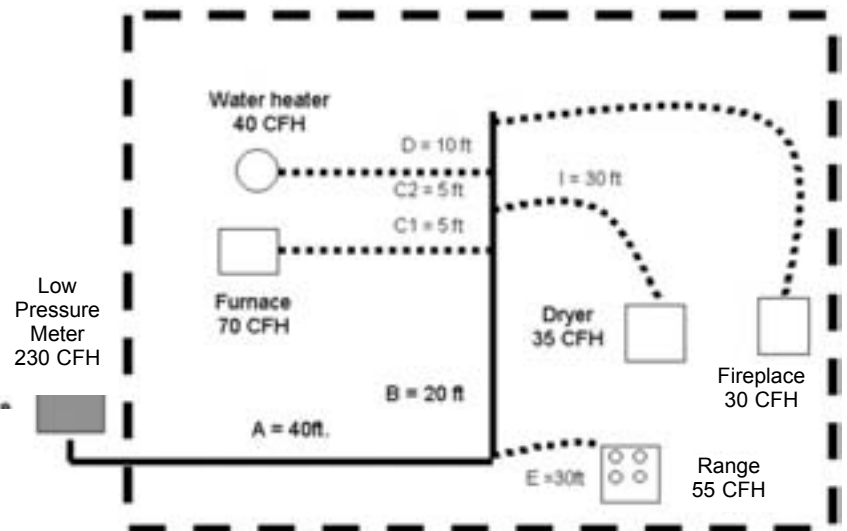

Figure: 3-8

- Begin by using pipe sizes determined in Example: 6 and determine if these are correct with this method. It is possible that smaller pipe sizes may be sufficient; this will be determined by calculating the sum of pressure losses from the meter to each appliance. To use this method a tentative size will be assigned to each run and this size will be confirmed or revised by the calculation. The sum total loss of a run from



the meter to the appliance cannot exceed the allowable pressure loss.

3. To determine pressure loss through section A (steel pipe truck), use the load through that section (230 CFH) for 1-1/4 inch steel pipe and find the pressure loss per foot using Table: PD-2A. (Since 230 CFH is not listed in the chart you must extrapolate the pressure drop using the two flow rates above and below the desired capacity.) This would equate to approximately 0.0018 inch w.c. Pressure drop per foot. Multiply the length: 40 feet by the loss per foot: 0.0018. The pressure loss for this section is 0.072.
4. To determine the pressure loss through section B, we use the load through that section (175 CFH). Find the loss for 1 inch size using Table: PD-2A. This would be approximately 0.0041 inch w.c. per foot. Multiply the length: 20 feet by the loss per foot: 0.0041. The pressure loss for this section is 0.0820.
5. To determine the pressure loss through section C1 we use the load through that section (105 CFH). Find the pressure loss for 1 inch using Table: PD-2A. This would be approximately 0.0016 inch w.c. Multiply the length: 5 feet by the loss per foot 0.0016. The pressure loss for this section is 0.0080 inch w.c.
6. To determine pressure loss through section C2 we use the load through that section (70 CFH). Find the pressure loss for 3/4 inch using Table: PD-2A. This would be 0.0024 feet w.c. Multiply the length: 5 feet by the loss per foot: 0.0024. The pressure loss for this section is 0.0120 inches w.c.
7. To determine pressure loss through section D we use the load through that section (30 CFH). Find the pressure loss for 1/2 inch using Table: PD-2A. This would be 0.0020 inch w.c. Multiply the length: 10 feet by the loss per foot: 0.0020. The pressure loss for this section is 0.0200 inch w.c.
8. To determine pressure loss through section E (**TracPipe**® drop to range) use the load through that section (55 CFH) and extrapolate the pressure loss using Table: PD-1A. Trying the 3/4 inch column we find that the pressure loss would be approximately 0.0029 inch w.c. Multiply the length: 30 feet by the loss per foot 0.0029. The pressure loss for this section is 0.0870. Add the loss of section A to the loss of section E for the total loss from the meter to the range.  $0.072 + 0.0870 = 0.159$ . Since this is less than the 0.5 inch w.c. allowable drop the correct size for section E is 3/4 inch.
9. To determine pressure loss through section F (**TracPipe** drop to the furnace), use the load (70 CFH) and find pressure loss from Table: PD-1A. In the 3/4 inch column we find 0.0038. Multiply the length: 30 feet by 0.0038. The pressure loss for this section is 0.1140. Add the loss of sections A + B to the loss of section F for total loss from meter to furnace.  $0.072 + 0.082 + 0.114 = 0.2680$ . The correct size for section F is 3/4 inch.
10. To determine pressure loss through section G (**TracPipe** drop to the water heater), use the load (40 CFH) and find pressure loss from Table: PD-1. In the 1/2 inch column we find 0.0077. Multiply the length: 25 feet by 0.0077. The pressure loss for this section is 0.1925. Add the loss of sections A + B + C1 + C2 to the loss of section G for total loss from meter to furnace.  $0.072 + 0.0820 + 0.0080 + 0.1925 = 0.3545$ . The correct size for section G is 1/2 inch.
11. To determine pressure loss through section H (**TracPipe** drop to the fireplace), use the load (30 CFH) and find pressure loss from Table: PD-1. In the 1/2 inch column we find 0.0042. Multiply the length: 40 feet by 0.0042. The pressure loss for this section is 0.1680. Add the loss of sections A + B + C1 + C2 + D to the loss of section H for total loss from meter to fur-

nace.  $0.072 + 0.0820 + 0.0080 + 0.0120 + 0.1680 = 0.3420$ . The correct size for section H is 1/2 inch.

12. To determine pressure loss through Section I (**TracPipe**® drop to the Dryer), use the load (35 CFH) and find pressure loss from Table: PD-1. In the 1/2 inch column we find 0.006. Multiply the length: 30 feet by 0.006. The pressure loss for this section is 0.18. Add the loss of sections A + B + C1 to the loss of section I for total loss from meter to Dryer.  $0.072 + 0.0820 + 0.0080 + 0.18 = 0.3420$ . The correct size for section I is 1/2 inch. Using the Sum of Pressure Loss Method we calculate that three of the five **TracPipe** sections (when compared with the longest length method) can utilize reduced sizes to deliver the necessary load with a pressure loss equal to or less than the allowable 0.5 inches water column. This enables the installer to use 1/2 inch **TracPipe** on all but the furnace and range drops, which remain 3/4 inch.



# CHAPTER 4 INSTALLATION PRACTICES

## SECTION 4.1 — GENERAL INSTALLATION PRACTICES

Precautions must be taken to ensure that any exposed flexible piping is not damaged or abused during building construction. All system hardware should be stored in a secure, dry location prior to installation.

1. The piping system is for use with fuel gas and is rated for operating pressures up to 25 PSI. **TracPipe**® gas piping (3/8 inch up to 1-1/4 inch sizes) has been tested and is approved for pressures up to 125 PSI, and may ONLY be used at this pressure with the consent of the local gas utility and code authority. Pressure tests up to 125 PSI are permitted on sizes up to 1-1/4 inch if required by the authority having jurisdiction.
2. Only components provided by **OMEGA FLEX** or specified as part of the **TracPipe** piping system are to be used in the installation.

DO NOT USE **TRACPIPE** TUBING OR FITTINGS WITH TUBING OR FITTINGS OF ANY OTHER MANUFACTURER. INTERMIXING OF CSST TUBING OR FITTING COMPONENTS BETWEEN CSST MANUFACTURERS IS PROHIBITED. CONNECTIONS BETWEEN TWO DIFFERENT BRANDS OF CSST MAY ONLY BE ACCOMPLISHED USING STANDARD MALLEABLE IRON FITTINGS.

3. Ends of the piping are to be temporarily capped, plugged or taped closed prior to installation and pulling through structure to prevent entrance of dirt, or other debris.
4. Contact with sharp objects or harmful substances is to be avoided. **Contact with any chemicals containing chlorides or ammonia must be followed by thorough rinse and wipe dry.** Typical chloride based chemicals include fluxes used for soldering copper tubes and acid based cleaners such as muriatic acid used for cleaning brickwork. **Use only non-corrosive leak detection fluids.** (Available: **TracPipe** Leak Check Solution P/N FGP-LCS).

### 5. BENDING **TRACPIPE**

Undue stress or strain on the tubing or fittings is to be avoided. Bending flexible gas piping is one feature which contributes to the speed of installation. The recommended bend radius for general routing of tubing is listed in Table: 4-1. Multiple tight bends can restrict the gas flow and increase pressure drop. The tightest bend allowed for each size of **TracPipe**

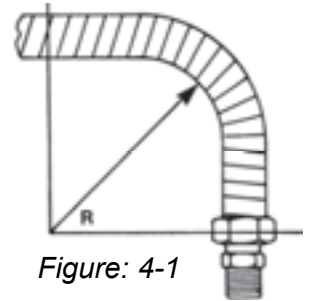

Figure: 4-1

### RECOMMENDED MINIMUM BENDING RADIUS FOR FLEXIBLE GAS PIPING

Table: 4-1

TUBING SIZE	ABSOLUTE MINIMUM BEND RADIUS R	RECOMMENDED MINIMUM BEND RADIUS (R)
3/8 inch	9/16 inch	3 inch
1/2 inch	3/4 inch	3 inch
3/4 inch	1 inch	3 inch
1 inch	3 inch	5 inch
1-1/4 inch	3 inch	5 inch
1-1/2 inch	3 inch	5 inch
2 inch	4 inch	6 inch

is shown in the chart below. Typical locations requiring tight bends are termination mount installations in hollow stud walls.

6. SUPPORTING **TRACPIPE**®

Piping shall be supported in a workmanlike manner with pipe straps, bands, brackets or hangers suitable for the size and weight of the piping. **TracPipe** which passes over or through a structural member is considered to be supported by that member.

6A. VERTICAL RUNS

Spacing of supports is not to exceed 10 feet, requiring hangers only where the height of each floor is greater than 10 feet.

6B. HORIZONTAL RUNS

Spacing of supports hangers, supports and anchors-piping shall be supported at intervals not to exceed those shown in Table: 4-2. It is acceptable to use standard pipe straps or tubing clips available in metal or plastic materials, **OMEGAFLEX** has found that the use of two-attachment point plastic clips or metal EMT pipe straps is advisable.

Some plastic clips, especially the "J-clips" designed to support plastic tubing are susceptible to breakage upon subsequent handling by other trades.

**HORIZONTAL OR INCLINED RUNS**

*Table: 4-2*

<b>PIPING SIZE</b>	<b>SPACING OF SUPPORTS</b>
3/8 inch	4 FEET
1/2 inch	6 FEET
3/4 inch	6 FEET
1 inch	6 FEET
1-1/4 inch	6 FEET
1-1/2 inch	6 FEET
2 inch	6 FEET

## SECTION 4.2 HOW TO ASSEMBLE *TracPipe*® *AutoFlare*® FITTINGS

### INSTRUCTIONS for Making Fitting Connections to Flexible Gas Piping

1. **CUT-TO-LENGTH:** Determine proper length. Cut through plastic jacket and stainless tube using a tube cutter with a sharp wheel. Cut must be centered between two corrugations. Use full circular strokes in one direction and tighten roller pressure slightly (a quarter turn) after each revolution. **DO NOT OVERTIGHTEN ROLLER**, which may flatten tube.

**NOTE:** Due to the large diameter and depth of corrugation on sizes over 1 inch, tubing must be cut with a standard tubing cutter RIDGID™ 152 or equal using a *TracPipe*® cutting wheel No. FGP-E-5272 (P/N E-5272 or equal).

**CAUTION:** Use of a small cutting wheel may flatten the first corrugation and make cutting and/or sealing of fittings difficult.

2. **STRIP JACKET:** Using a utility knife, strip back the jacket. See Table: 4-3 for approximate jacket strip length. Care should be taken to minimize the amount of jacket material removed. Caution: For your personal safety--Knife blade and cut tube ends are both sharp. Use care when cutting the jacket and handling the tube.

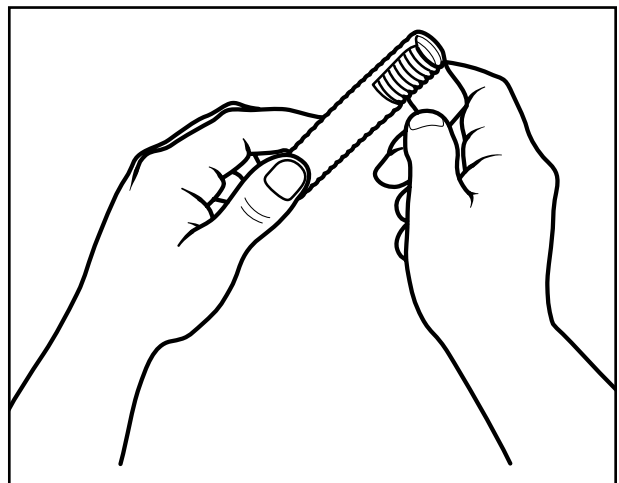
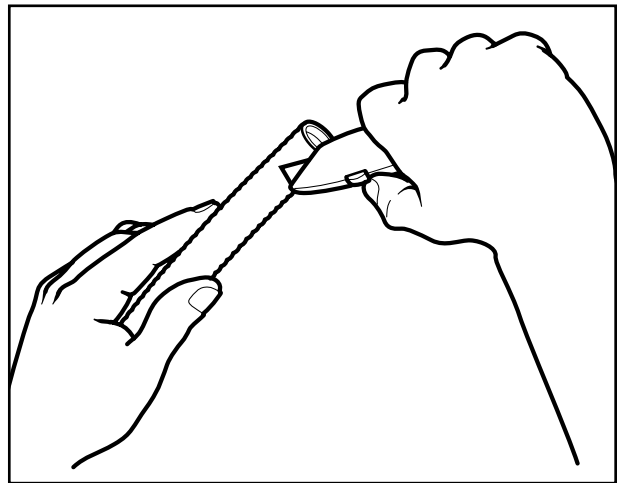
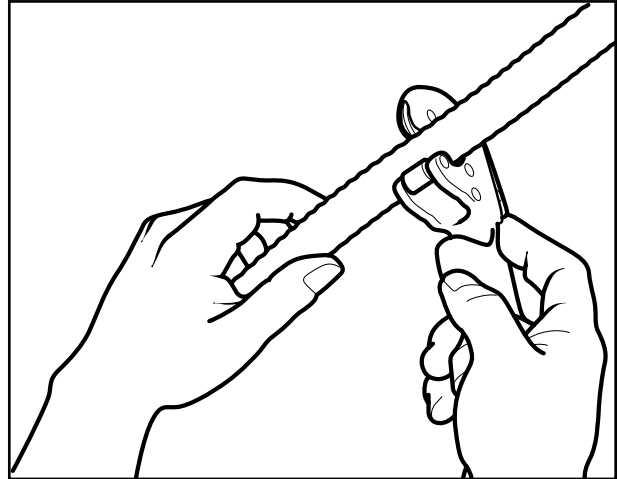

Table: 4-3

**APPROX STRIP LENGTH**

Tubing Size		FST Fittings	Termination Type and PS-II Fittings
3/8"	-375	1-1/8"	1-1/2"
1/2"	-500	1-3/16"	1-1/2"
3/4"	-750	1-1/4"	1-3/4"
1"	-1000	1-3/8"	2"
1-1/4"	-1250	1-5/8"	2-1/4"
1-1/2"	-1500	1-5/8"	2-1/2"
2"	-2000	2"	2-3/4"

## INSTRUCTIONS for making Fitting Connections to Flexible Gas Piping (Continued)

3. **INSTALL FITTING NUT:** Slide nut over cut end: place two split-rings into the first corrugation next to the tube cut. Slide nut forward to trap the rings.

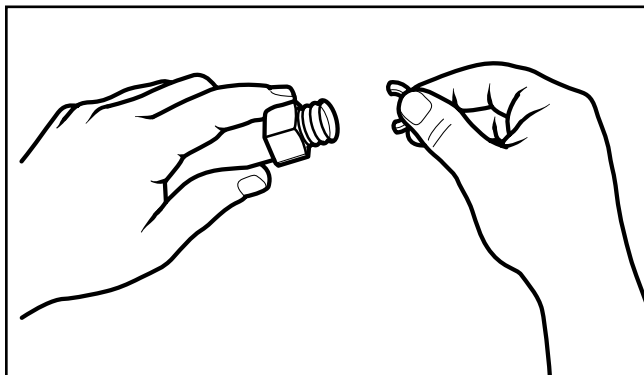

4. **WRENCH FITTING:** Place the adapter into the nut and engage threads. Note that the **AutoFlare®** fitting is designed to form a leak tight seat on the stainless tubing as you tighten the fitting. (The piloting feature of the adapter will not always enter the bore of the tubing before the tightening operation, but will center the fitting when tightened). Using appropriate wrenches, tighten the fitting until adapter bottoms and the resistance to wrenching increases greatly. The flare has now been created on the tubing end.

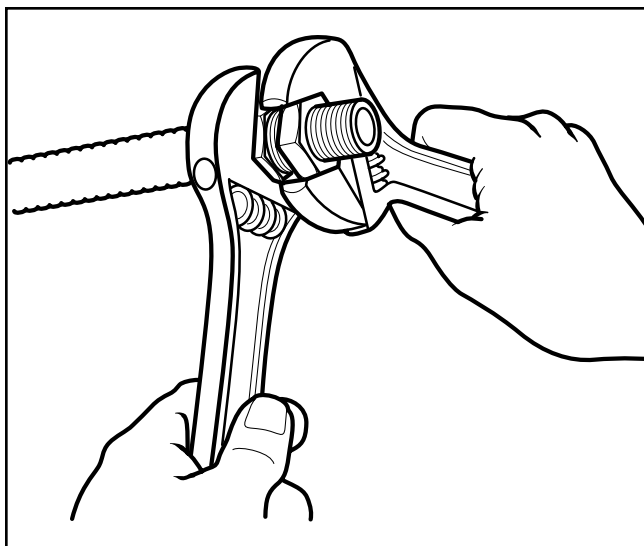

**CAUTION: DO NOT USE ANY THREAD SEALANTS FOR THIS CONNECTION. SEALANTS ARE TO BE USED ON THE PIPE THREAD ONLY.**

5. **FINAL TORQUE:** Tighten nut and adapter to the torque values shown in Table: 4-4. For field installations use the following method: Tighten nut and adapter as though you were making up a flared tubing joint. Note relation between hex flats at this point and continue to tighten for two additional hex flats (one-third turn) to obtain required torque and final leak-tight seal.

*Table: 4-4*

Flexible Pipe Size	Fitting	Torque Value
3/8" FGP-SS4-375	FGP-FST-375	40 feet-lb.
1/2" FGP-SS4-500	FGP-FST-500	42 feet-lb.
3/4" FGP-SS4-750	FGP-FST-750	45 feet-lb.
1" FGP-SS4-1000	FGP-FST-1000	75 feet-lb.
1-1/4" FGP-SS4-1250	FGP-FST-1250	150-200 ft.-lb.
1-1/2" FGP-SS4-1500	FGP-FST-1500	200-250 ft.-lb.
2" FGP-SS4-2000	FGP-FST-2000	250-300 ft.-lb.



*AutoFlare® (Patented) – The Fitting is the Flaring Tool*

## SECTION 4.2A — TROUBLE SHOOTING FITTING CONNECTIONS

1. The tubing cut is the critical step in the fitup procedure. Always cut in a straight section of piping, rather than an area you have bent. Use light roller pressure applied on every revolution to cut tube evenly around its surface. Remember that this tube has a thinner wall than the copper tube you are accustomed to cutting. A sharp blade is very important, and it will be helpful to reserve one cutter for stainless steel only.
2. If the fitting connection cannot be made to seal upon applying torque per the instructions in Section 4.2, continue to tighten an additional quarter to a half turn. If leakage continues, do not continue to apply torque. Disassemble the fitting and inspect the sealing surfaces. The most likely cause of leakage is foreign material on the sealing surfaces. Wipe both fitting and tubing flare with a clean cloth. Inspect the formed flare on the tubing end, which should appear round when compared with the split ring washers and the nut in place. If any deformation is noted, the tubing can be recut and the fitting re-attached. The patented Autoflare fitting has an insert which is self piloting and does not require special tooling to make a leak proof fitting.
3. REASSEMBLY - When reattaching the AutoFlare fitting, it is only necessary to

re-insert the split rings into the space between the first two corrugations and to pull the nut back over the rings into position. The adapter can then be conveniently re-threaded into the nut and torqued as before. If the nut cannot be pulled into place, examine the split-rings, which may have been “coined” by the first torque operation. If this is the case, simply reverse the split-rings positioning to align with the nut and continue the assembly process. If the fitting is reattached more than three times, or if the nut cannot be pulled over the rings in any position, then the split-rings must be replaced. Packets of spare split-rings are available (P/N FGP-RING-SIZE) and the remaining fitting parts can be re-used.

## SECTION 4.3 — ROUTING

Depending on local building codes and construction practice, Flexible gas piping can be routed:

1. Beneath floor joists, through floor and ceiling joists, along side of floor and ceiling joists. This is the typical location for residences and commercial buildings with basements and for multi-floor systems. Multiple tubing runs may be bundled.

2. Inside hollow interior wall cavities. This is the preferred location for vertical sections of piping, rather than horizontal sections.
3. Through approved duct underground or encased in solid floor. When piping runs are located below grade or within solid floors, the **TracPipe**® shall be routed within a non-metallic water-tight duct. No tubing joints are permitted within the floor. Gas piping runs encased within a solid floor shall be ventilated. See Underground Installation, Section 4.9 for underground use of **TracPipe PS-II**. **TracPipe PS-II** meets code requirements for underground and encased in solid floor installations.
4. Clearance holes for routing the piping through studs, joists, plates etc. shall have a diameter at least 1/2 inch larger than the outside diameter of the piping. When a structural member must be drilled, conformance to building codes must be followed. No structural member shall be seriously weakened or impaired by cutting, notching or otherwise altering the member. Minimum drill hole sizes are listed in Table: 4-5.

Table: 4-5

TUBING SIZE	DRILL HOLE SIZE
3/8 inch	1-1/8 inch
1/2 inch	1-3/8 inch
3/4 inch	1-1/2 inch
1 inch	1-3/4 inch
1-1/4 inch	2-1/4 inch
1-1/2 inch	2-1/2 inch
2 inch	3 inch

#### 5. METAL STUDS

For installations involving horizontal runs through galvanized steel studs, the use of plastic grommets supplied by the stud manufacturer is recommended. The use of these grommets will reduce the likelihood of damage to the tubing non-metallic jacket.

6. Care shall be taken to route the tubing in areas that are least susceptible to potential threats wherever possible. Flexible gas piping larger than 1 inch internal diameter installed within hollow cavity walls of 2 x 4 construction shall be protected along the entire concealed length.

### SECTION 4.3A — CONCEALED LOCATIONS FOR FITTINGS — GENERAL PROVISIONS

The **AutoFlare**® mechanical attachment fittings have been tested and are listed per the requirements of ANSI LC1 and CSA 6.26 Standard (USA and CANADA) This specification provides test requirements which certify fittings for concealed installations and connections to appliances where concealing the fittings is the only practical alternative.

These guidelines address some of the known situations which may require the use of a concealed fitting. While accessibility of fittings may be desirable, there are often situations where concealing the fittings is the only practical option. This guide cannot address all applications of concealed fittings, but provides instead typical instructions to demonstrate the principles which apply to fittings listed for installation in concealed locations.

#### EXCLUSIONS:

1. Manifold Stations (for 2 PSI systems) which include the multiport manifold, shut off valve, and pressure regulator shall not be installed in concealed locations regardless of the qualifications of tubing fittings.

#### NEW INSTALLATIONS:

1. CSST may be connected to steel piping systems through threaded pipe connections. This can be a stub-out to an appliance connection or outdoors to a meter, etc.
2. Flexible piping connections to fireplace “key valves” can be located in a concealed location, when accessibility is not readily



provided. See Figure: 4-2 and Figure: 4-3 for typical key valve mountings.

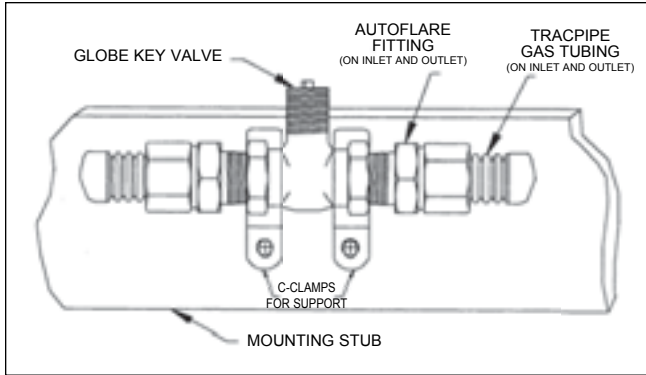

Figure: 4-2

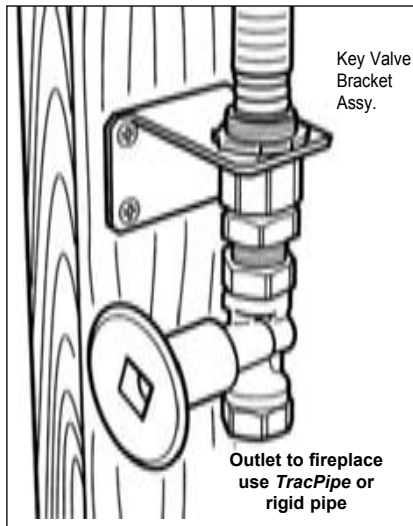

Figure: 4-3

- Multiple gas outlets – when multiple outlets are supplied from a single run of piping, each downstream outlet branch can be connected to the main run using a tee fitting which can be located in a concealed location. (See Figure: 4-4).

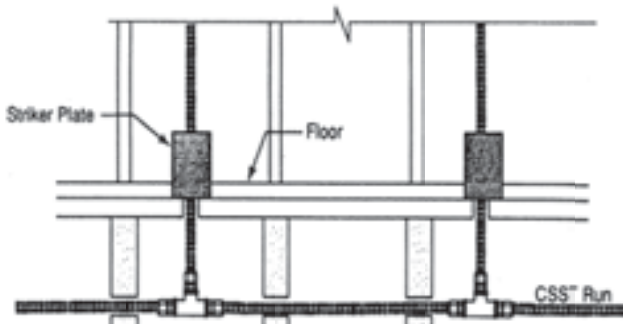

Figure: 4-4 Multiple outlets along main tubing run

## MODIFICATIONS TO INSTALLED SYSTEMS:

- New ceilings in unfinished rooms/basements- Flexible piping fittings originally installed in accessible ceiling locations can be concealed at a later date in the event that a ceiling is installed. Precautions shall be taken to ensure that the newly concealed piping and fittings are adequately protected from accidental puncture in accordance with the instructions in this guideline.
- Extensions to existing tubing runs-A tubing run can be modified to permit an extension to another appliance location provided there is sufficient capacity to supply both appliances at the same time. If an accessible location for the modification is not available, the existing tubing run can be modified with a tee fitting, resulting in a concealed fitting.
- Repairs to existing tubing runs-Damaged tubing runs shall be repaired in accordance with instructions in this guide (Section 5.2). The repair can result in a line splice which may ultimately be located in a concealed location.

## SECTION 4.3B — OUTDOOR INSTALLATION ISSUES

The following section provides instructions for the use of **TracPipe**® in systems in which portions of the piping are exposed to the outdoors as required to make connections to gas meters or appliances which are attached to, mounted on, or located in close proximity to the building structure. ANSI/IAS LCI-CSA 6-26 contains test requirements determining suitability for exposure of CSST piping systems to outdoor environments. **TracPipe**® is certified to this standard and is fully qualified for outdoor installations. The **TracPipe**® yellow jacket contains UV inhibitors to retard jacket degradation when exposed to long periods of sunlight.

- When installed outdoors, the plastic jacketing shall remain intact as much as practical for the given installation. Any portions of exposed stainless steel shall be wrapped with self bonding silicone tape sealing the fitting connection to prevent later corrosive attack by acid wash or chloride based compounds. (See Figures: 4-5 and 4-6).

2. When **TracPipe**® is installed in a swimming pool mechanical room or exposed to a corrosive environment which may be harmful to the tubing, all exposed portions of the stainless steel tubing shall be wrapped with self-bonding tape. (See Figures: 4-5 and 4-6).
3. When installed along the side of a structure (between the ground and a height of 6 feet) in an exposed condition, the **TracPipe**® shall be installed in a location which will not subject the piping to mechanical damage or be protected inside a conduit.

**NOTE:** For support and protection, **OmegaFlex**® recommends that outside runs along the side of a building be clipped securely to the wall or other structural component.

4. **TracPipe**® shall not be buried directly in the ground or penetrate concrete unless it is sleeved inside of a non-metallic (PVC or use **TracPipe**® **PS-II** Polyethylene) water tight conduit. The conduit shall be sealed at any exposed end to prevent water from entering. See instructions for underground installations Section 4.9.

5. When installed underneath mobile homes or in crawl spaces, **TracPipe**® shall be installed in accordance with these standard outdoor instructions.

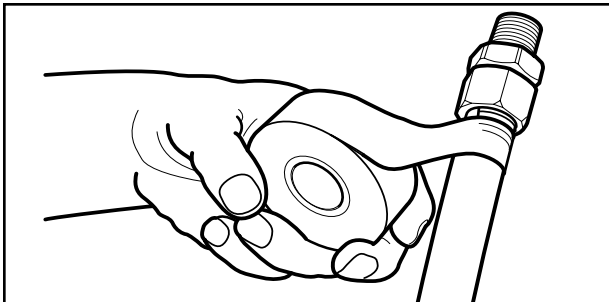

Figure: 4-5 Wrapping with self bonding silicone tape - begin on jacket.

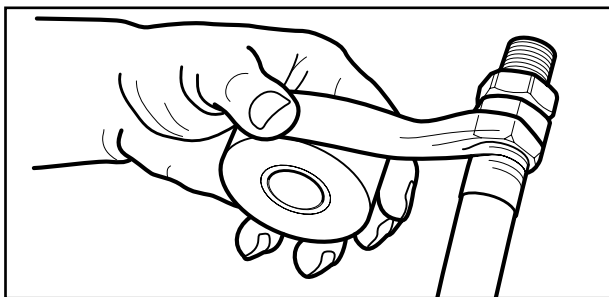

Figure: 4-6 Wrapping with self bonding silicone tape - end on nut.

## SECTION 4.4 — PROTECTION

The flexible gas piping must be adequately protected from puncture, shear, crush or other physical damage threats. The tubing shall be protected at points of support and when passing through structural members such as studs, joists and plates in accordance with this section. PROTECTION IS REQUIRED WHENEVER THE TUBING IS CONCEALED, RESTRAINED, AND WITHIN 3 INCHES OF A POTENTIAL THREAT. If the tubing requires protection, the following measures should be taken.

### SECTION 4.4A — STRIKER PLATE REQUIREMENTS

1. Install shielding devices i.e. striker plates to protect the tubing from penetration by drill bits, nails, screws, etc. in those areas where the tubing will be concealed and will not be free to move to avoid such puncture threats.

**NOTE:** Only CSA approved hardened striker plates listed for CSST systems may be used.

- a. At support points and points of penetration less than 2 inches away from any edge of a stud, joist, plate, etc. shielding is required at the area of support and within 5 inches of

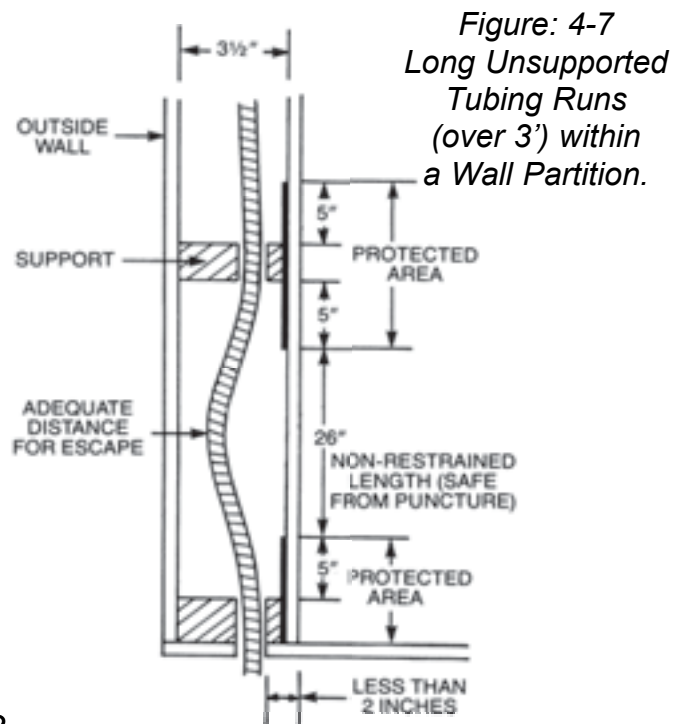

Figure: 4-7 Long Unsupported Tubing Runs (over 3') within a Wall Partition.

each side (if appropriate). Use a half striker or a full striker plate in these locations. (Figure: 4-7).

- b. At support points and points of penetration 2 to 3 inches from any edge of stud, joist plate, etc. shielding is required throughout area of support. Use a quarter striker plate in these locations. (Figure: 4-8).

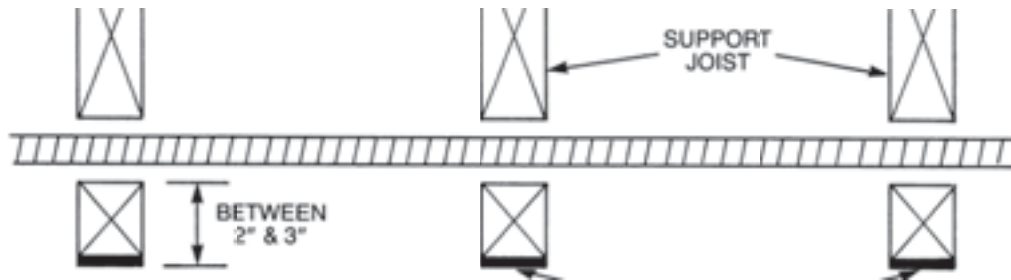

Figure: 4-8  
Shielding Requirements at Support Area when Points of Penetration are 2-3 inches from any Edge of a Stud, Joist, Plate, etc.

- c. Hardened steel striker plates provide the required protection through building structures as described above. Type RW Floppy steel conduit shall be installed as additional protection at termination points. (Figure 4-9).

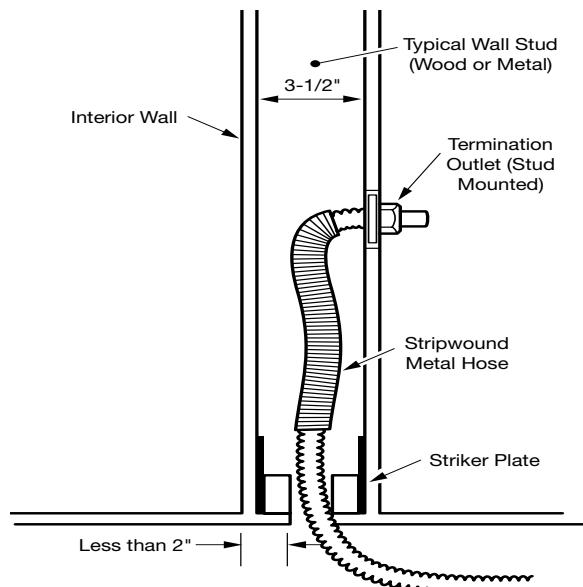

Figure: 4-9

- d. When tubing is routed horizontally between studs, install quarter striker plates at each stud and floppy galvanized steel conduit (spiral metal hose) along the entire length.
- e. Schedule 40 steel pipe has been tested by CSA International and found acceptable

for puncture protection. Steel pipe can be used where standard striker plates cannot reasonably be installed. Examples of this type of use include: (but are not limited to) outside walls of buildings with sheathing in place, between floors with enclosed joist areas, and retrofits in existing buildings with walls in place. Steel pipe having an inner diameter at least one-half inch larger than

the **TracPipe**® O.D. is approved by CSA International for this use as an alternate to striker plates. Protection must extend 5 inches beyond the penetration of the structural member(s). A 12 inch pipe length is appropriate for penetration of a single stud. **Omegaflex** recommends the use of standard striker plates where the building construction permits their installation. See Table: 4-6 for pipe sizes.

TracPipe Size	Steel Pipe Size
3/8 inch	1-1/4 inch
1/2 inch	1-1/4 inch
3/4 inch	1-1/2 inch
1 inch	2 inch
1-1/4 inch	2-1/2 inch
1-1/2 inch	2-1/2 inch
2 inch	3-1/2 inch

Table: 4-6

- 2. The best protection is to install the tubing in those out of the way areas where testing has shown no protection is necessary, for example:
  - a. Where the tubing is supported more than 3 inches from any outside edge of a stud, joist, plate, etc. or wall surface. (Figure: 4-10).

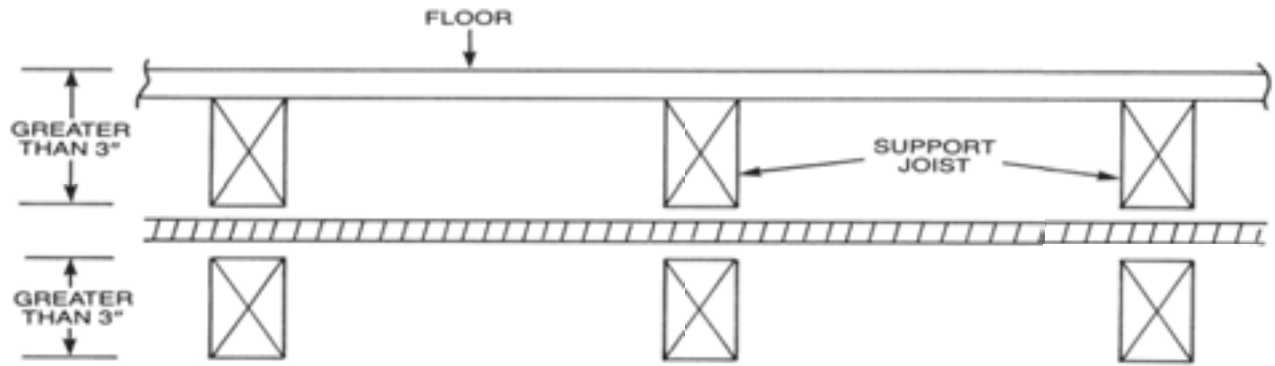

Figure: 4-10

*No Shielding Requirement at Support Area when Points of Penetration are greater than 3 inches from any Edge of a Stud, Joist, Plate, etc.*

- b. Where any non-restrained tubing can be displaced from the direction of potential penetration at least 3 inches.
  - c. When tubing is supported under the joists in basements or crawl spaces and is not concealed by wallboard or ceilings.
  - d. In unfinished garage walls where tubing is exposed.
3. **TracPipe**® with its specially formulated yellow polyethylene jacket has been tested to the flame spread and smoke density requirements of ASTM E84 and meets ANSI LC-1 limits imposed for this criteria.
  4. For through-penetration fire stop instructions refer to the UL classification requirements shown in appendix A. When passing through a fire stop (2hr. wall) the YELLOW jacket does not have to be removed. Seal between building and **TracPipe**® with an approved 3M type CP-25 or equivalent caulk.
  5. **TracPipe**® has thru-penetration UL Classifications for 1, 2 and 4 hour requirements depending on materials and type of construction. See Appendix A.
  6. **CounterStrike**® meets building code requirements (ASTM E84) with respect to flame spread and smoke density. This permits installation in drop ceilings used as return air plenums.
  7. **CounterStrike**® has thru-penetration UL Classifications for 1, 2 and 4 hour requirements depending on materials and type of construction. See Appendix A.

**NOTE:** For **TracPipe**® **PS-II** tubing version with black outer jacket, the installer shall meet local building codes with respect to flame spread and smoke density regulations for non-metallic materials. **Omegaflex**® recommends either removing the black jacket or transitioning to the standard yellow jacketed product when passing through areas such as drop ceiling return plenums.

## SECTION 4.5 — METER CONNECTIONS

1. Meters which depend on the service and house piping for support shall not be directly connected to the flexible piping. Instead, use a meter termination fitting or termination mount fitting with steel pipe for the outdoor portion of the connection. For mounting of meters, all fastener locations should be used when installing the flange or mounting plate. (Figures: 4-11 and 4-12).
2. Meters which are independently supported with a bracket can be directly connected outdoors with **TracPipe**<sup>®</sup>. (See Figure: 4-13). If practical, direct connections shall include a 3 to 6 inch additional length of tubing to accommodate differential settling and meter movement. No mechanical protection of the tubing is required for outdoor connections. PRIOR TO INSTALLING **TRACPIPE**<sup>®</sup> DIRECTLY TO A METER, ENSURE THAT THE LOCAL UTILITY ALLOWS THIS PRACTICE as some utilities have regulations specifying meter attachments. Any exposed sections of stainless steel piping must be wrapped with a silicone self-bonding tape. This is especially important with masonry construction. (See Figure: 4-12). A PVC sleeve is required for **TracPipe**<sup>®</sup> penetration of masonry and recommended for wood frame construction.

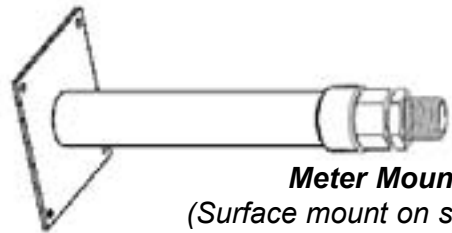

**Meter Mount**  
(Surface mount on sheathing or through the rim joist.)

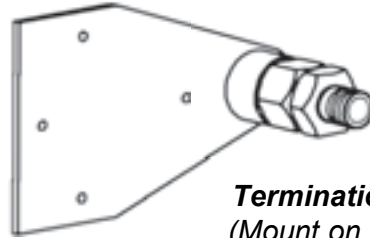

**Termination Mount**  
(Mount on one stud.)

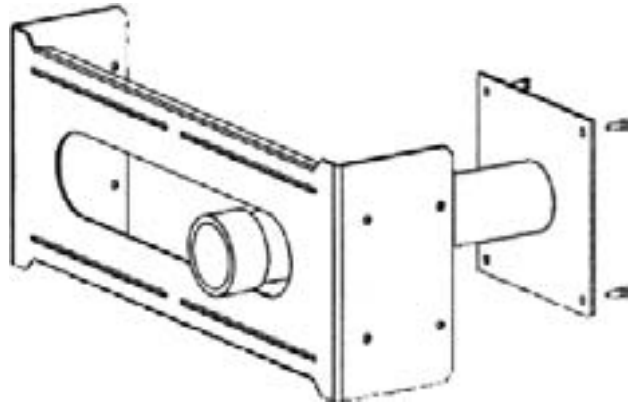

**Stud Bracket**  
(Mount between two studs.)

Figure: 4-12  
Meter Mounting Accessories

**Note:** Diameter of hole shall be at least 1/2" greater than O.D. of tubing and shall be sleeved and/or sealed in accordance with local building code (if applicable).

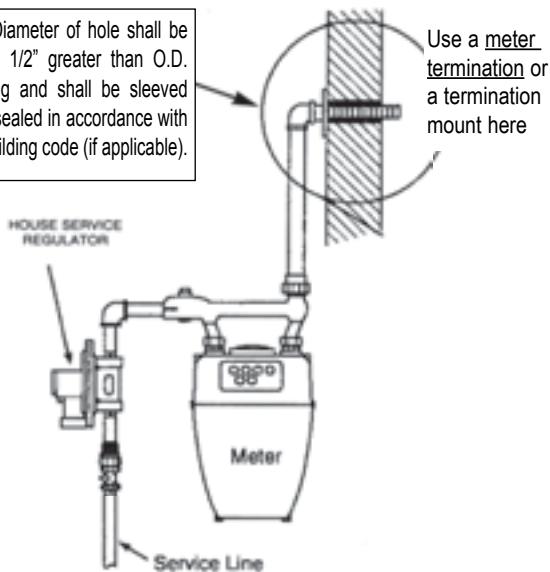

Figure: 4-11

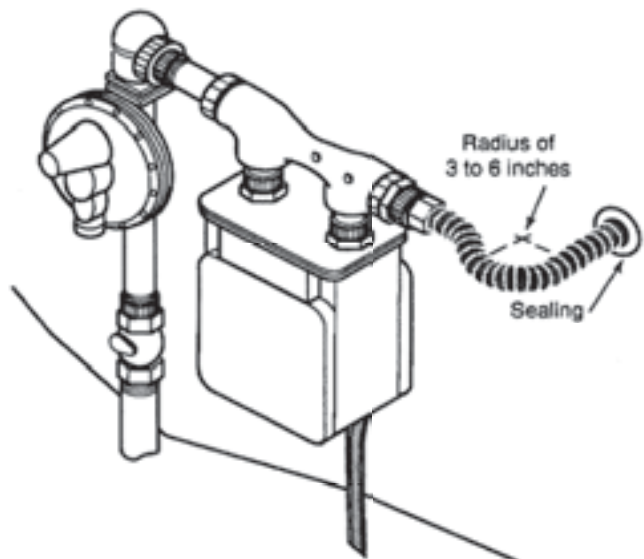

Figure: 4-13

**SECTION 4.6 — CSST  
Connection to Outdoor Propane  
Tanks (Located in Close  
Proximity to the Building)**

To provide for vertical or horizontal movement that may be experienced with outdoor propane tanks due to freeze/thaw ground conditions, **TracPipe**® Flexible Gas Piping may be installed in a loop configuration as shown in Figure: 4-14. Use Table: 4.7 to determine loop diameter based on size used.

The tank shall be in a fixed condition on a level pad and not subject to tipping or other movement other than that covered in this section.

The tank shall be of the fill in place type (not the exchange type) and located in close proximity to the building. **TracPipe**® used for this application is to be downstream of 2nd stage pressure reduction only. Movement of the tank shall not exceed 15 cm.

Installation shall be done by trade professionals trained to install **TracPipe**® products, and be in compliance with the **TracPipe**® Design and Installation Guide and all applicable codes and standards. **TracPipe**® is not listed for propane in the liquid state.

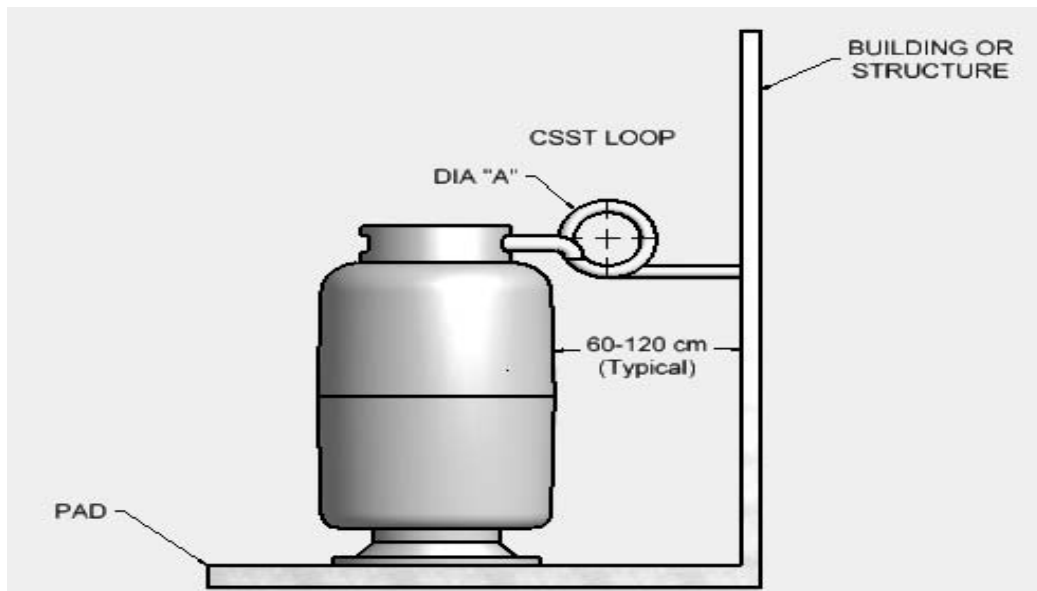

Figure: 4-14

Size	Dia. □A□min	Max. Movement
3/8□(12 mm)	33 cm	15 cm
1/2□(15 mm)	38 cm	15 cm
3/4□(22 mm)	46 cm	15 cm
1□(28 mm)	56 cm	15 cm

Table: 4-7

## SECTION 4.7 — APPLIANCE CONNECTIONS

A listed termination outlet (termination mount or flange fitting) shall be installed and secured to the structure at all floor and hollow wall piping outlets used for moveable appliances and quick disconnect devices. The termination outlets are designed to simplify the installation of gas connections for movable appliances and minimize the need for concealed fittings. The flange fitting or plate shall be securely fastened in place during rough-in. It may be attached to a brace spanning between studs for a wall location, or directly to the floor. (See Figure: 4-14). The flange may also be mounted with a flange L- bracket, which is nailed or screwed to the stud.

When a moveable appliance is in a location

where a termination outlet cannot be readily installed through the structure, the **TracPipe®** can be transitioned to black pipe at a suitable location and the black iron pipe fastened to the block walls or concrete. Another option is to use termination mounting bracket fastened to the block wall and make the drop with **TracPipe®**. Final connection is with a flexible appliance connector. (See Figure: 4-14).

1. MOVABLE APPLIANCE CONNECTIONS (SUCH AS RANGES AND DRYERS) SHOULD BE MADE USING APPROVED FLEXIBLE APPLIANCE CONNECTORS. (See Figure: 4-15). See also recessed wall box next page.
2. FIXED APPLIANCE CONNECTIONS MAY BE DIRECTLY CONNECTED TO THE FLEXIBLE GAS PIPING SYSTEMS

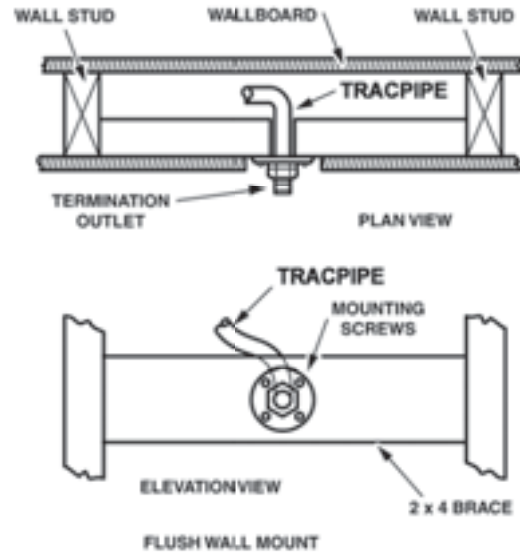
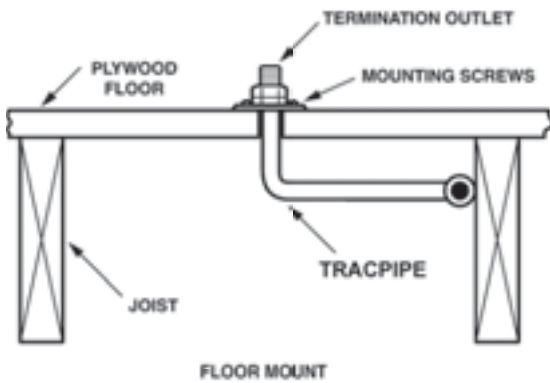

Figure: 4-14  
Support Device Flange Termination Outlet

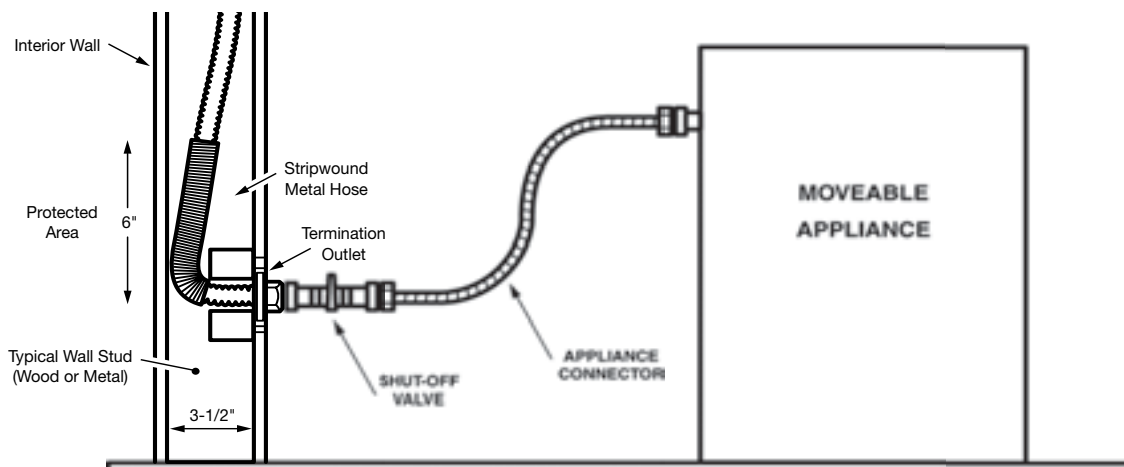

Figure: 4-15 Stainless Steel Gas Connector Connection to a Movable Gas Appliance

(in most jurisdictions). When the fixed appliance is located in a secure, dedicated space, such as a basement, attic, garage or utility closet, the flexible piping may be directly connected to the appliance shut-off valve without installation of a flange fitting or flexible appliance connector.

3. RECESSED WALL BOX

**TracPipe®** Part Number FGP-WBT-SIZE  
(Not fire rated)

**TracPipe®** Part Number FGP-WBTM-SIZE  
(Fire rated to UL 1479)

Product Description: **TracPipe®** Recessed Wall Box makes possible appliance stub outs with zero clearance for a finished appearance in laundry rooms, kitchens and mechanical rooms. This accessory provides a rigid attachment point for appliance connectors serving movable appliances.

3A. Wall Box Installation Instructions

1. Install **TracPipe®** gas pipe and cut to desired length using a tubing cutter with sharp wheel. Strip yellow jacket back approximately 2 inch. Inspect pipe for a clean cut without tears.

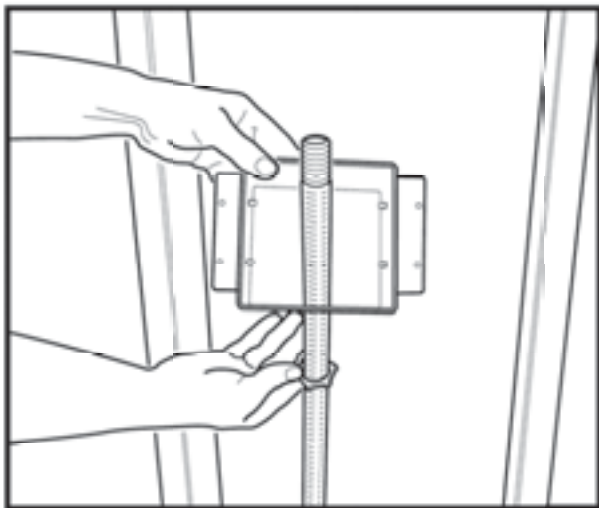

2. Remove box cover and slip locknut and box over end of pipe.

**Note:** Mounting tabs are oriented for a single layer of drywall. When two layers are used for some 2-HR rated walls, remove screws on tabs and invert mounting tabs.



**Caution:** FGP-WBTM is fire rated to UL 1479. This box has been designed for use with **TracPipe®** Flexible Gas Piping as an appliance termination and is not suitable for connection to any other CSST brand or black iron pipe. Installers must be trained on **TracPipe®** before installing this product.

**BOX**

**COVER**

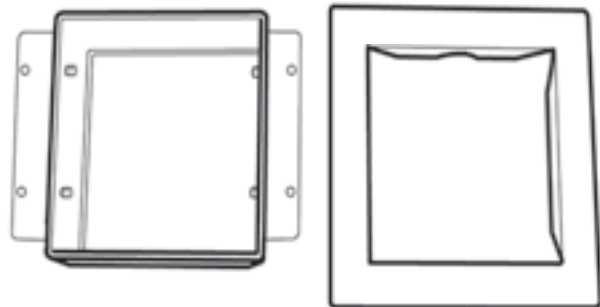

P/N FGP-WBT shown



VALVE



NUT



SPLIT RINGS



LOCKNUT



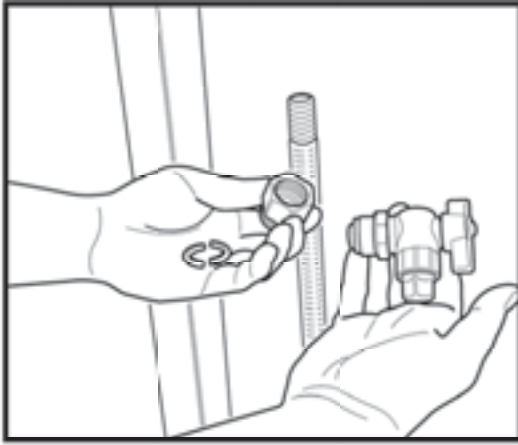

3. Disassemble valve and split rings from nut.

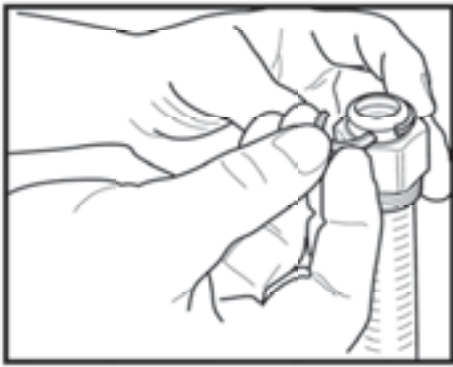

4. Slip nut over end of pipe and insert split rings into valley of the first corrugation.

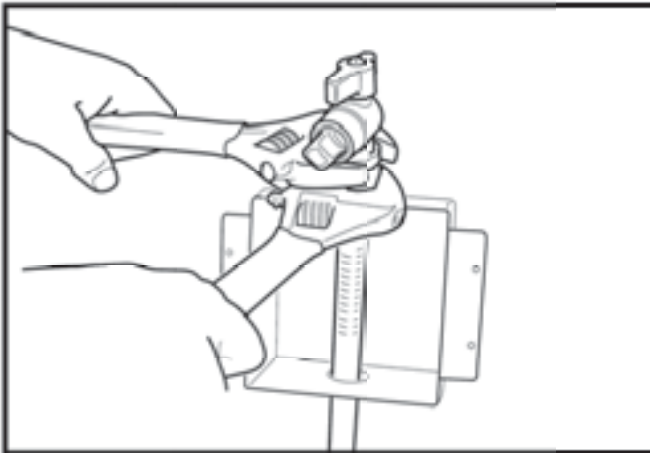

5. Thread 90 degree ball valve onto nut and tighten so valve outlet faces forward. It is recommended that crescent wrenches be used to avoid damaging valve or nut.  
**Do not use thread sealants on this connection.**

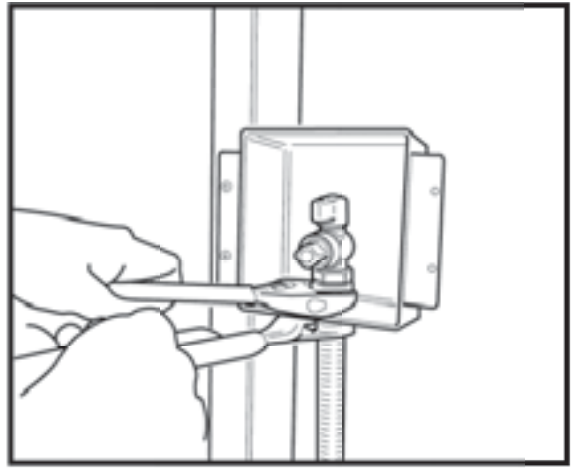

6. Slide box up and over the threads on the bottom of the nut and mount box to stud.

7. Secure valve assembly to box with lock-nut.

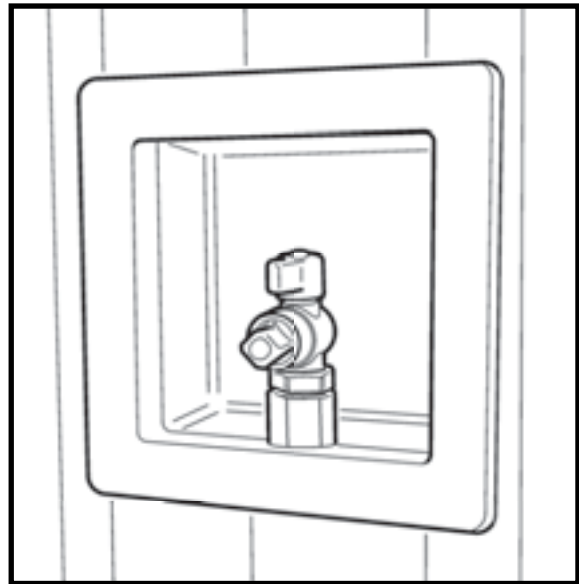

8. Install box cover after completion of dry-wall. If the gap between the edges of the box and the drywall is less than 1/4", no fire caulking is required.

**Note:** These instructions must be used in conjunction with the *TracPipe*® Design and Installation Guide. *TracPipe*® flexible gas piping material must only be installed by a qualified person who has been trained through the *TracPipe*® Gas Piping Installation Program.

## SECTION 4.7A — PAD MOUNTED EQUIPMENT, ROOF TOP EQUIPMENT

1. Gas appliances mounted on concrete pads or blocks, such as gas air conditioners, heat pumps, pool heaters and NGV refueling stations, shall be connected to the **TracPipe**® system at a termination fitting using either rigid pipe or an approved outdoor appliance connector. Direct connection of **TracPipe**® to pad mounted equipment is permitted when the CSST is securely supported and located where it will be protected from physical damage. Follow local and provincial codes.

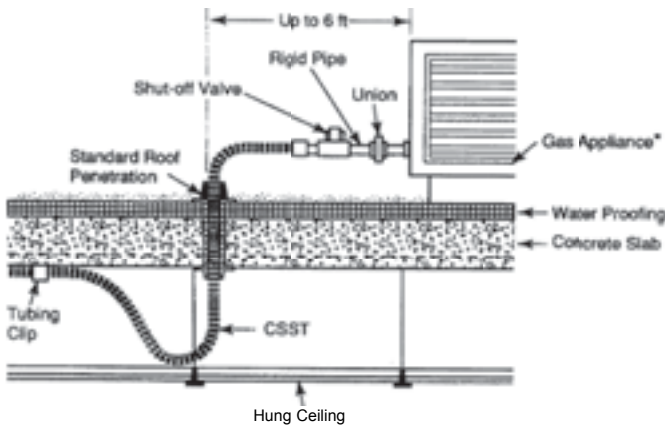

Figure 4-16 Short (1-6 foot) outdoor connection to roof mounted equipment

2. No special mechanical protection of the piping is required for connection to roof top equipment. Whenever possible, roof penetrations shall be located within 6 feet of the equipment to be connected as shown in Figure: 4-16. Long runs of tubing shall be supported with non-metallic blocks at

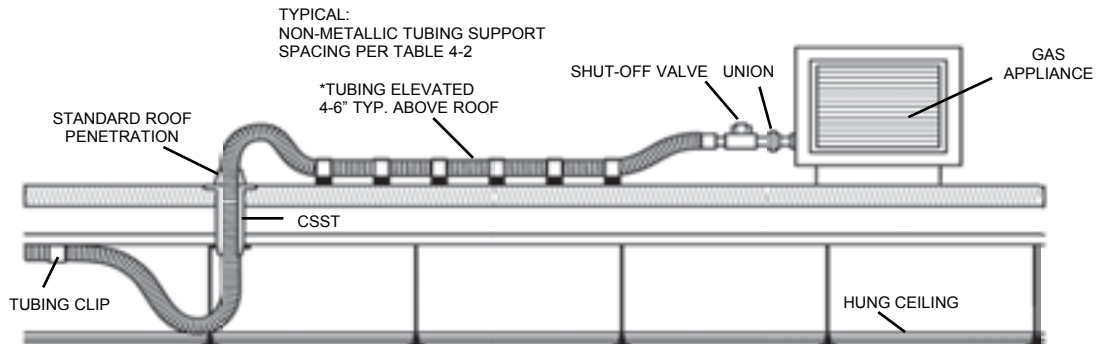

Figure 4-17

\*HEIGHT OF ELEVATION BASED ON LOCAL PLUMBING/BUILDING CODE REQUIREMENTS AND/OR WINTER ICE BUILDUP.

the support interval listed in Table: 4-2, and raised above the roof a distance determined by local code/practice.

3. **TracPipe**® may be supported with strut/channel running from block to block beneath the flexible gas pipe. Galvanized shallow channel (13/16 inch) with splice plates at joints and bends provides a secure, damage resistant “track”. With metallic strut support, blocks can be reduced to every 8 feet. The **TracPipe**® should be firmly attached to each block with metallic clamps designed for the strut or appropriate fastening mechanism. (See Figure: 4-18). Black cable ties (UV resistant) at intermediate points facilitate rolling out the **TracPipe**®. The blocks are to be attached to the roof surface in accordance with the roofing manufacturer’s instructions.

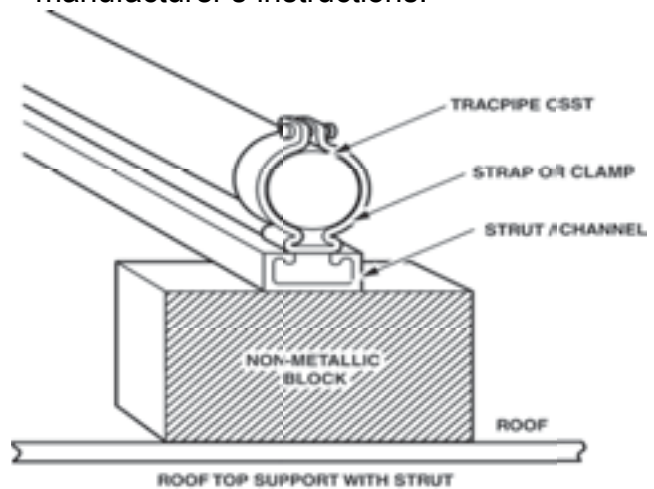

Figure 4-18

4. Piping run vertically up the side of the building shall be protected in accordance with the General Provisions section of the outdoor use guidelines (Section 4.3B).

## SECTION 4.7B — OUTDOOR APPLIANCES — BARBECUE GRILL AND GAS LIGHT CONNECTIONS

1. Movable grills shall be connected using an approved outdoor appliance connector which shall be attached to the flexible piping system at either a termination mount fitting, a transition to a steel nipple, or a quick-connect device such as the M. B. Sturgis Model 3/375 shown in Figure: 4-19. The quick-connect outlet shall be installed in accordance with manufacturer's instructions.
2. Permanently mounted grills located on decks shall be connected with the **TracPipe**® system as shown in Figure: 4-20 and in accordance with this guide. The outdoor portion of the piping shall be supported against the side of any of the inside deck joists. If the elevation of the deck is below the top of the foundation, any exposed piping shall be protected using water-tight non-metallic conduit.

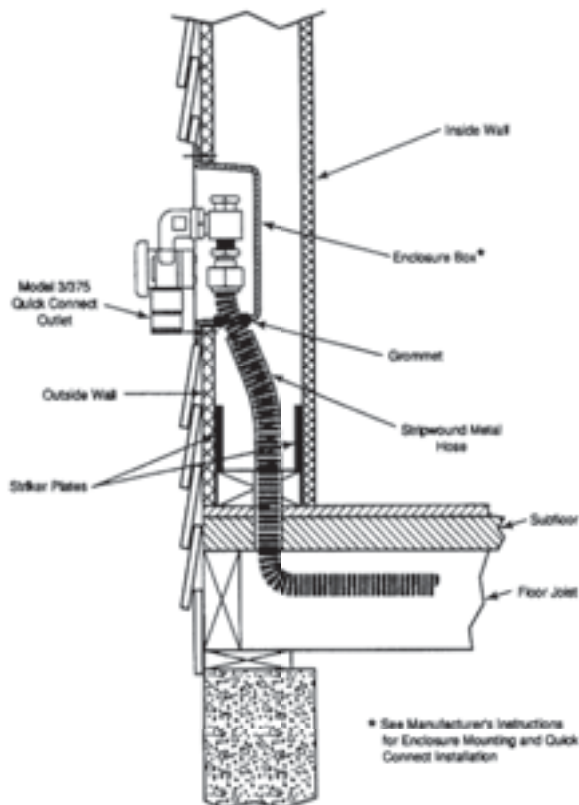

Figure: 4-19

3. Permanently mounted lights located on decks shall be connected to the piping system the same as permanently mounted grills shown in Figure: 4-20 and in accordance with the manufacturer's instructions.

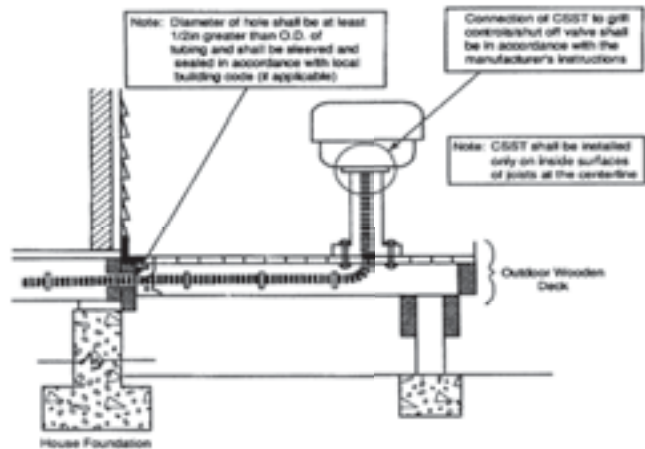

Figure: 4-20

4. Yard mounted lights shall be connected to the **TracPipe**® system as shown in Figure: 4-21. All piping installed below grade shall be protected by non-metallic, water-tight conduit or **TracPipe**® PS-II for underground use. Exposed ends of the conduit shall be sealed against water entry.

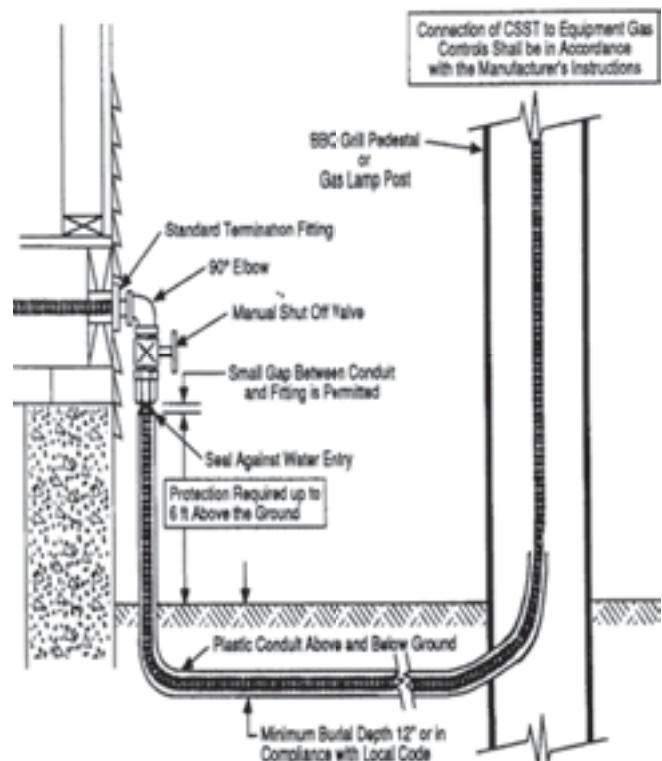

Figure: 4-21

## SECTION 4.7C — FIREPLACE INSTALLATIONS

1. **TracPipe**® may be used to deliver gas directly to the valve for a gas fireplace. This is approved for decorative and heat generating fireplaces and for gas logs used in masonry and pre-fabricated fireplaces. DO NOT use **TracPipe**® to connect gas log lighters or gas wands for use in all-fuel (woodburning) fireplaces. See Figure: 4-22).
2. Most gas fireplaces and gas logs (Refer to ANSI Z24.60) fall into the definition of fixed appliances which can be directly connected to **TracPipe**® without the use of a flange mount fitting. The attachment is generally to the shut-off valve which may be located in the control area beneath the burner unit or at the side of the log set. **TracPipe**® can be run into the lower control area for attachment without removal of the polyethylene jacket. In vented fireplaces, attachment to gas logs is best accomplished by removal of the jacket inside the fire box. This precludes direct flame contact with the polyethylene jacket. Stainless steel melting temperatures (2000° F) are consistent with black iron.
3. For gas log lighter installations in all-fuel fireplaces, the **TracPipe**® run MUST be terminated at the key valve or another location outside the fireplace. The final

attachment should be made using black iron pipe.

4. When it is necessary to install **TracPipe**® through sheet metal enclosures, such as those commonly used in decorative gas fireplaces, the manufacturer's recommendation is to leave the protective yellow polyethylene jacket in place through the sheet metal penetration. The **TracPipe**® should be clipped to the building structure at a suitable location outside the fireplace to limit the amount of motion after installation. If additional protection is required, such as an installation with a source of vibration (fan, etc.) which may cause abrasion, then a short piece of floppy conduit or PVC pipe may be used between the jacket and the enclosure.
5. In masonry fireplace installations of decorative gas appliances (log sets) it is recommended to leave the polyethylene jacket in place throughout the masonry penetration providing a non-metallic sleeve for the flexible stainless steel. Caulking can then take place between the jacket and the penetration at interior and/or exterior locations. Remove the jacket inside the firebox. If additional protection is required, the **TracPipe**® may be sleeved using PVC pipe in addition to the included jacket.
6. The FGP-FPT may be used in all applications where it is desirable not to penetrate the enclosure with tubing. (See Figure: 4-23).

### MASONRY FIREPLACE

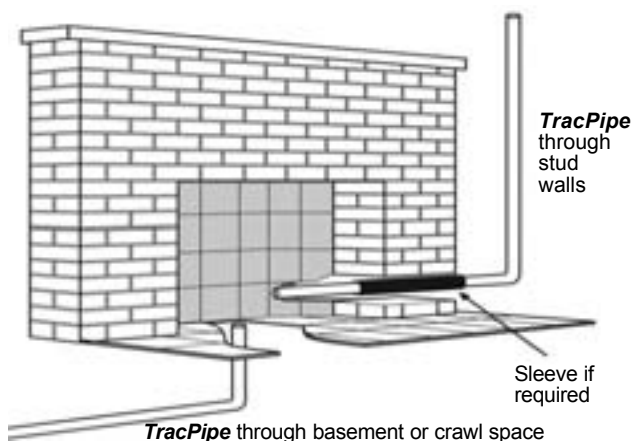

Figure: 4-22

### METAL FABRICATED FIREPLACE

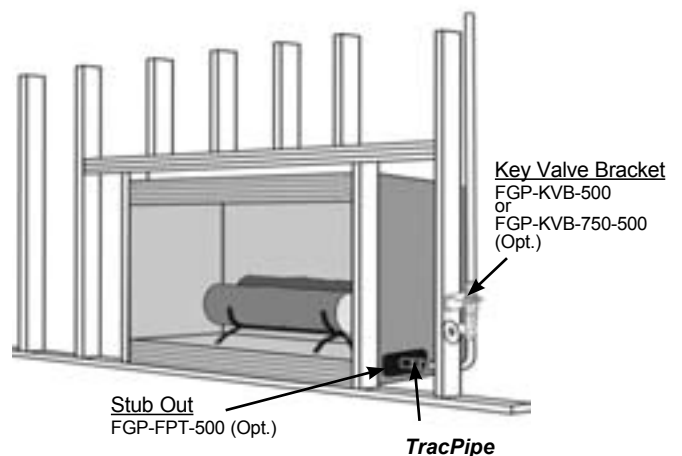
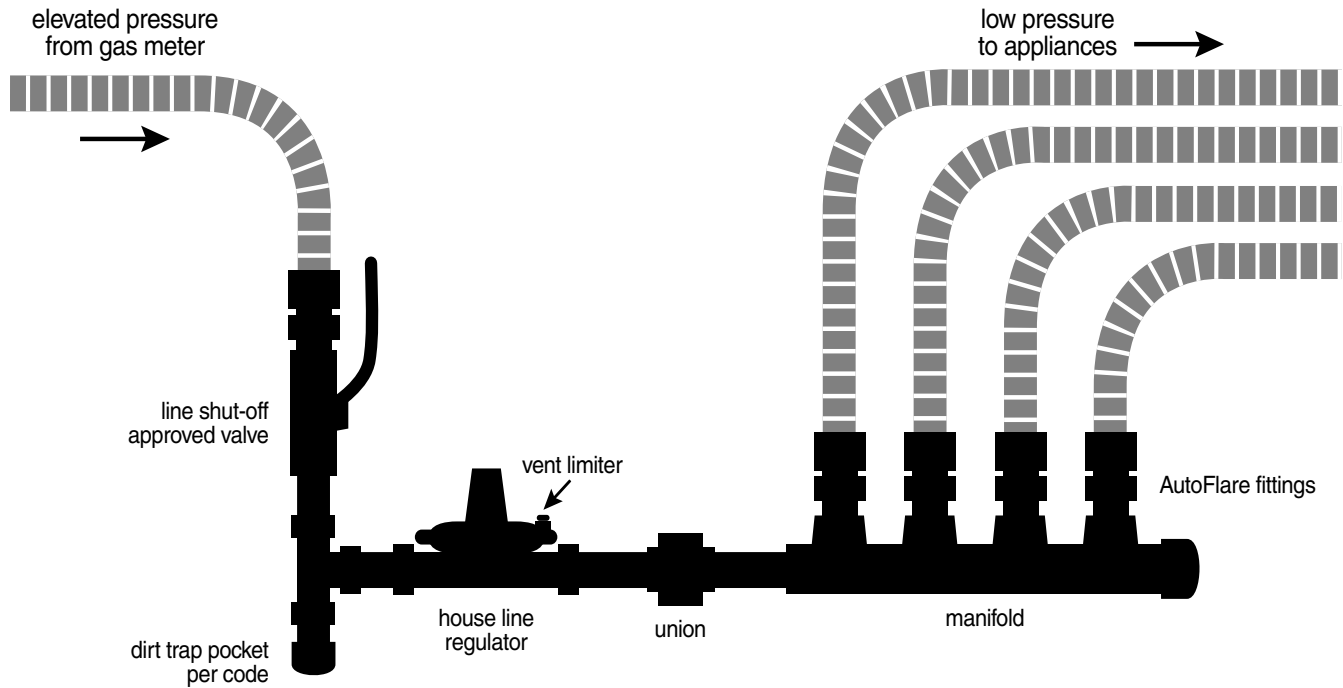

Figure: 4-23



## SECTION 4.8 — MANIFOLD AND REGULATOR STATION

The use of a central manifold and regulator station is recommended for elevated pressure systems which are typically installed in a parallel arrangement to take advantage of the capacity of the regulator, which is sufficient for several appliances. Manifolds are available with the *TracPipe*® system, or the use of black iron pipe and tee fabricated manifolds is permitted with this system. The manifold/regulator station should be located nearby the largest gas consuming appliances, typically the furnace or boiler and the water heater in order to allow short runs to these units.

The manifold station **MUST** be located in an accessible location because of the shut-off valve(s) and regulator it contains. The manifold station may be contained in an enclosure box called a gas load center. Optional gas shut-off valves may be mounted on the manifold for each appliance run.

Manifolds installed on low pressure systems or in locations removed from the regulator may be concealed.

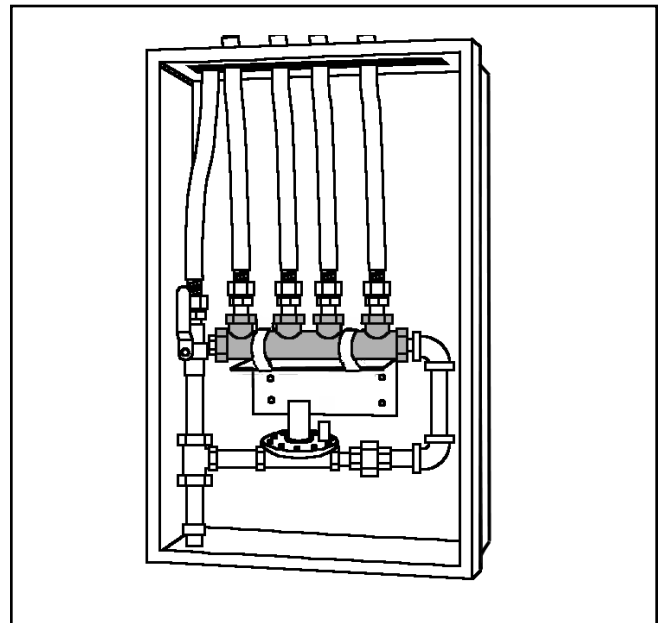

**Gas Load Center**

## SECTION 4.8A — REGULATORS AND ELEVATED PRESSURE SYSTEMS

A tubing system used at gas pressures exceeding 1/2 PSI but serving appliances rated for 1/2 PSI maximum, shall contain a pounds-to-inches regulator to limit the downstream pressure to no more than 1/2 PSI. The regulator must incorporate a lock-up feature limiting downstream pressure to 1/2 PSI under no flow conditions. The regulator shall comply with the applicable provisions of ANSI Z21.18/CSA 6.3, ANSI Z21.80/CSA 6.22 or other recognized regulator standard.

Regulators used to reduce elevated system pressures for use by appliances must also conform to the following:

1. Must be sized to supply the required appliance load.(See chart below).

### Supply Pressure and Capacities

Based on flow in cubic feet per hour

P/N	1/2 PSI (34 mbar)	3/4 PSI (52 mbar)	1 PSI (69 mbar)	1-1/2 PSI (103 mbar)
FGP-REG-3	145 (4.1)	200 (5.7)	250 (7.1)	250 (7.1)
FGP-REG-5A	335 (9.5)	475 (13.5)	550 (15.6)	550 (15.6)
FGP-REG-7L	690 (19.5)	970 (27.5)	1000 (28.3)	1000 (28.3)

2. Must be equipped with an acceptable vent limiting device, supplied by the manufacturer, or be capable of being vented to the outdoors. The vent-limiting device can be used when the regulator is installed in a ventilated area. **OMEGAFLEX** ships all regulators with vent-limiters installed.

**NOTE:** For outdoor venting, the line must be at least the same size as the regulator vent connection, and cannot exceed a length of 30 feet. The vent shall be designed to prevent entry of water, insects or other foreign materials that could cause blockage of the line. **DO NOT VENT TO APPLIANCE FLUE OR BUILDING EXHAUST SYSTEM. DO NOT VENT TO PILOT LIGHT.**

3. MUST BE INSTALLED IN ACCORDANCE WITH MANUFACTURERS INSTRUCTIONS. WHEN A VENT-LIMITER IS USED

THE REGULATOR MUST BE MOUNTED IN AN UPRIGHT POSITION. INSTALL THE REGULATOR PROPERLY WITH GAS FLOWING AS INDICATED BY THE ARROW ON THE CASTING.

4. Must be installed in a fully accessible area with an approved shut off valve ahead of regulator. An optional union will enable removal of the regulator if the location does not otherwise permit removal for servicing. The ability of the autoflare fitting to allow disassembly and reattachment provides for regulator removal in most instances.
5. Line regulators do not vent gas under normal operating conditions. Any regulator found to be venting gas should be replaced immediately. Vent-limiters are required to limit venting in the event of a diaphragm failure, within the regulator, to limits identical to those imposed on a gas appliance control valve.
6. An area is considered to be ventilated if the combustion, ventilation or dilution air is obtained from the occupied areas of the building, or from outside, or from both, into the common areas of the appliance locations. Reference applicable codebook for details.
7. For outdoor installations remove the vent limiter and mount regulator with the vent outlet pointing down to prevent the entrance of water. A plastic cap FGP-CAP-3 is available for outdoor installations permitting regulator to be mounted in an upright position.

## SECTION 4.8B — REGULATOR ADJUSTMENTS

1. Regulators can be adjusted to deliver different outlet pressures within a limited range. The range is determined by the spring installed.
2. Adjustment can be accomplished by first removing the regulator seal cap to expose the adjusting screw. Turning the screw clockwise will increase outlet pressure, turning it counter-clockwise will decrease pressure.

3. If spring adjustment will not produce desired outlet pressure, check to make sure supply pressure is at least equal to desired outlet pressure plus pressure drop of the regulator. If supply pressure is adequate, consult factory if adjustment still cannot be made. Do not continue to turn regulator adjusting

screw clockwise if outlet pressure readings do not continue to increase. THIS MAY RESULT IN OVER-FIRING DUE TO LOSS OF PRESSURE CONTROL, SHOULD THERE BE A SUBSEQUENT INCREASE IN INLET PRESSURE.

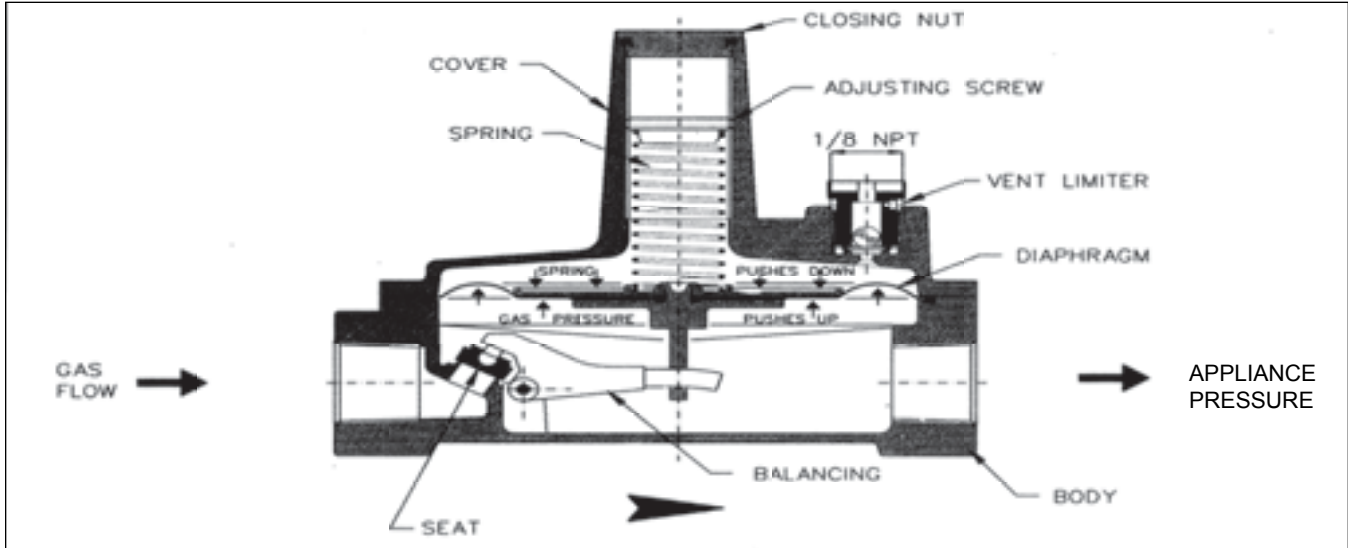

## SECTION 4.8C — REGULATOR SUPPLY PRESSURE AND CAPACITIES DROP FOR SINGLE AND MULTIPLE APPLIANCES

NATURAL GAS 0.64 SPECIFIC GRAVITY

REGULATOR CAPACITIES expressed in CFH (m3/h) 0.64 Specific Gravity Gas

Regulator Application	Part Number	NPT SIZE	Maximum Single Appliance Load	Outlet Pressure Set Point	Operating Inlet Pressure			
					1/2 psi (34 mbar)	3/4 psi (52 mbar)	**1 psi (69 mbar)	***1-1/2 psi (103 mbar)
2 psig	FGP-REG-3	1/2"	140 (4.0)	8" w.c.	145 (4.1)	200 (5.7)	250 (7.1)	250 (7.1)
2 psig	FGP-REG-3P	1/2"	140 (4.0)	11" w.c.	93 (2.6)	172 (4.9)	225 (6.4)	250 (7.1)
2 psig	FGP-REG-5A	3/4"	300 (8.5)	8" w.c.	335 (9.5)	475 (13.5)	550 (15.6)	550 (15.6)
2 psig	FGP-REG-5P	3/4"	300 (8.5)	11" w.c.	211 (6.0)	391 (11.1)	511 (14.5)	550 (15.6)
2 psig	FGP-REG-7L	1"	900 (25.5)	8" w.c.	690 (19.5)	970 (27.5)	1000 (28.3)	1000 (28.3)
2 psig	FGP-REG-7L	1"	900 (25.5)	*11" w.c.	441 (12.5)	816 (23.1)	1000 (28.3)	1000 (28.3)
								***
5 psig w/ OPD	FGP-REG-3L47	1/2"	125 (3.5)	8" w.c.	125 (3.5)	125 (3.5)	125 (3.5)	125 (3.5)
5 psig w/ OPD	FGP-REG-3L47	1/2"	125 (3.5)	*11" w.c.	105 (3.0)	125 (3.5)	125 (3.5)	125 (3.5)
5 psig w/ OPD	FGP-REG-3L48	1/2"	200 (5.7)	8" w.c.	160 (4.5)	200 (5.7)	200 (5.7)	200 (5.7)
5 psig w/ OPD	FGP-REG-3L48	1/2"	200 (5.7)	*11" w.c.	120 (3.4)	200 (5.7)	200 (5.7)	200 (5.7)
5 psig w/ OPD	FGP-REG-5AL48	3/4"	320 (9.1)	8" w.c.	320 (9.1)	320 (9.1)	320 (9.1)	320 (9.1)
5 psig w/ OPD	FGP-REG-5AL48	3/4"	320 (9.1)	*11" w.c.	245 (6.9)	320 (9.1)	320 (9.1)	320 (9.1)
5 psig w/ OPD	FGP-REG-5AL600	3/4"	425 (12.0)	8" w.c.	345 (9.8)	425 (12.0)	425 (12.0)	425 (12.0)
5 psig w/ OPD	FGP-REG-5AL600	3/4"	425 (12.0)	*11" w.c.	260 (7.3)	425 (12.0)	425 (12.0)	425 (12.0)
5 psig w/ OPD	FGP-REG-5AL601	1"	465 (13.2)	8" w.c.	375 (10.6)	465 (13.2)	465 (13.2)	465 (13.2)
5 psig w/ OPD	FGP-REG-5AL601	1"	465 (13.2)	*11" w.c.	285 (8.1)	465 (13.2)	465 (13.2)	465 (13.2)

\* Requires manual field adjustment of regulator to obtain 11" w.c. outlet pressure

\*\* Recommended sizing column for 2 psig Natural Gas TracPipe CounterStrike installations refer to Table N-5 Section 7.0.

\*\*\* Recommended sizing column for 5 psig Natural Gas TracPipe CounterStrike installations refer to Table N-6 Section 7.0.

## PROPANE 1.53 SPECIFIC GRAVITY

### REGULATOR CAPACITIES expressed in CFH (m3/h) 1.53 Specific Gravity Gas

(MBTUh values based on Gas with a heating value of 2520 BTU per cubic foot)

Regulator Application	Part Number	NPT SIZE	Maximum Single Appliance Load	Outlet Pressure Set Point	Operating Inlet Pressure			
					1/2 psi (34 mbar)	3/4 psi (52 mbar)	**1 psi (69 mbar)	1-1/2 psi (103 mbar)
2 psig	FGP-REG-3P	1/2"	91 (2.6) [229 MBTUh]	11" w.c.	60 (1.7) [152 MBTUh]	112 (3.2) [281 MBTUh]	146 (4.1) [368 MBTUh]	162 (4.6) [409 MBTUh]
2 psig	FGP-REG-5P	3/4"	195 (5.5) [491 MBTUh]	11" w.c.	137 (3.9) [345 MBTUh]	254 (7.2) [639 MBTUh]	332 (9.4) [836 MBTUh]	357 (10.1) [899 MBTUh]
2 psig	FGP-REG-7L	1"	584 (16.5) [1472 MBTUh]	*11" w.c.	286 (8.1) [721 MBTUh]	529 (15.0) [1334 MBTUh]	649 (18.4) [1635 MBTUh]	649 (18.4) [1635 MBTUh]

\* Requires manual field adjustment of regulator to obtain 11" w.c. outlet pressure

\*\* Recommended sizing column for 2 psig Propane TracPipe CounterStrike installations refer to Table P-3 Section 7.0.

**CAUTION:** Recent code changes require the use of 5-PSI labeled regulators in 5-PSI systems. Regulators labeled 2-PSI are not approved for 5-PSI use.

CONSULT THE REGULATOR MANUFACTURER FOR ADDITIONAL CAPACITY & PRESSURE DROP INFORMATION.

**NOTE:** All supply pressures in excess of 2 PSI, the new ANSI Z21.80 Line Regulator Standard requires a means (an Over-Pressure protection device /OPD), approved and tested with 5-PSI or 2-5 PSI Labeled regulator - to limit the downstream pressure to 2-PSI maximum, in the event of regulator failure. 5 PSIG Regulators with OPD are Z21.80 CSA Design certified with vent limiters for Natural Gas ONLY. To utilize these regulators on Propane systems above 2-PSIG, vent limiters should be removed and local codes followed for venting of regulators.

## SECTION 4.8D — OVER-PRESSURE PROTECTION

At supply pressures in excess of 2-PSI the ANSI Z21.80 line regulator standard requires a means - an over-pressure protection device (OPD)-approved and tested with the regulator- to limit the downstream pressure to 2-PSI maximum, in the event of regulator failure.

To comply with the ANSI Standard and with the B149.1 Natural Gas and Propane Installation code, all installations exceeding 2-PSI (primarily 5-PSI systems, but including all other elevated pressure installations higher than 2-PSI nominal) require a tested and approved overpressure protection device for use with the pounds-to-inches regulator. This require-

ment applies to line regulators, but not to appliance regulators.

Regulators for 5 PSI systems must be shipped as an assembled unit from our factory, regulator with OPD attached. Consult the current **TracPipe®** Price List for information regarding part numbers and capacity.

## SECTION 4.9 — UNDER-GROUND INSTALLATIONS

### 1. CODE REQUIREMENTS

When gas piping runs are located below grade in contact with earth or other material that could corrode the piping, codes require that the gas piping is protected against corrosion.

When piping is installed in solid floors, codes allow the piping to be encased in a duct and the duct ventilated. The duct shall be designed to withstand the superimposed loads. **TRACPIPE®** DOES NOT PERMIT THE INSTALLATION OF COUPLINGS OR FITTINGS WITHIN THE FLOOR.

### 2. REGIONAL/MODEL CODES

**PS-II (patented)** installations conform to the underground fuel gas installation requirements of B149.1 Natural Gas and Propane Installation Code.

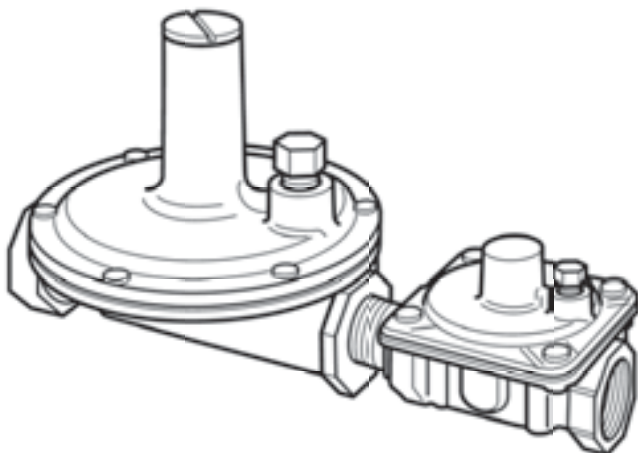

Regulator with OPD attached



## SECTION 4.9A — GUIDELINES FOR UNDER- GROUND INSTALLATIONS

TABLE: 4-8

1. Lay *TracPipe*® *PS-II* in a trench. Install the gas piping on a continuous solid surface per code to the appropriate burial depth as defined in Table: 4-9.
2. When transitioning *TracPipe*® *PS-II* from below grade or above the floor, use the recommended minimum bend radius as depicted in Figure: 4-24 and shown in Table: 4.8.

RECOMMENDED MINIMUM BENDING RADIUS FOR <i>TracPipe</i> PS-II	
Tube Size	Minimum Bend Radius R PS-II
3/8 inch	6 inches
1/2 inch	6 inches
3/4 inch	8 inches
1 inch	10 inches
1-1/4 inch	12 inches
1-1/2 inch	16 inches
2 inch	18 inches

**WARNING:** *TracPipe*® *PS-II* Systems must only be installed by a qualified person who has been trained through the *TracPipe*® Gas Piping Installation Program. All installations must comply with local code requirements and the instructions contained in the *TracPipe*® Design and Installation Guide.

3. Recommended exposed clearance height (height to the *TracPipe*® fitting above grade) is 12 inches minimum when terminating at this point. For vertical runs up the outside of a building in traffic areas, protect the *TracPipe*® as explained in Section 4.3B.
4. Avoid bending the above grade vertical portion of the *TracPipe*® *PS-II* piping

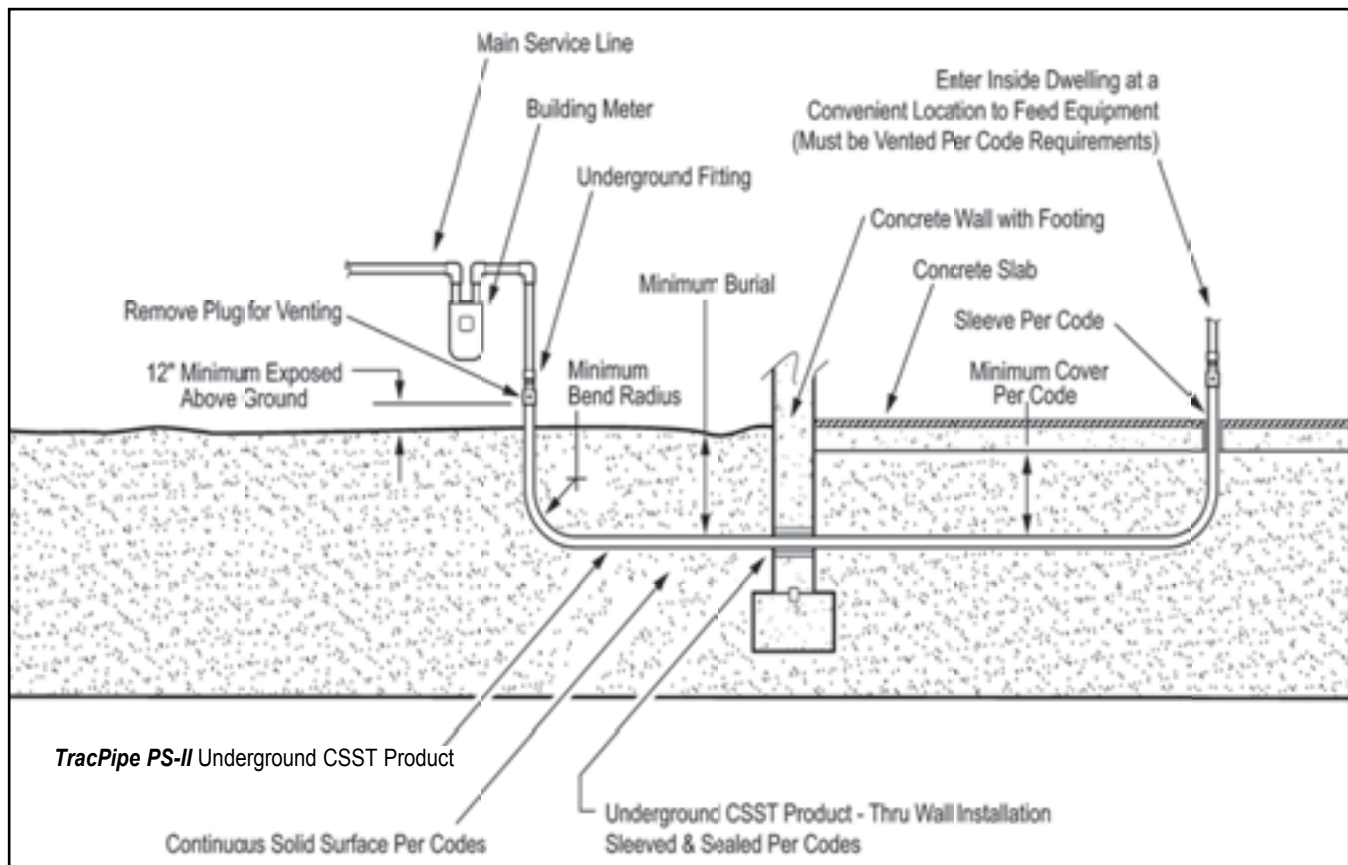

Figure: 4-24

beyond the Minimum Bend radius in Table: 4-8. To make a tighter bend in order to line up for a wall penetration, use a rigid fitting such as a malleable iron 90.

5. **TracPipe® PS-II** is suitable for above ground installations and is resistant to U.V. exposure. Portions rising above grade should be rigidly supported by direct attachment to a wall or independent support, (e.g. metallic strut) or by connection to rigid downstream piping or fittings (e.g. at a meter or Propane second stage regulator)
6. When installing **TracPipe® PS-II** underground through a foundation wall the space between the gas piping and the building shall be sealed to prevent entry of gas or water.
7. **TracPipe® PS-II** can penetrate directly through a concrete slab unless other requirements are established by local codes concerning slab penetrations and firestop requirements.

8. **TracPipe® PS-II** can be transitioned to standard **TracPipe®** piping above grade using **TracPipe® AutoFlare®** fittings with a **TracPipe® PS-II** Coupling P/N FGP-UGC-SIZE. Remove the black plastic vent coupling on the standard **TracPipe®** side.

Alternatively use a malleable iron coupling for the transition.

9. **TracPipe® PS-II** must be transitioned above ground to standard **TracPipe®** when routing through plenums or through penetration firestop installations. The black sleeve is not qualified for these locations.
10. Venting of **TracPipe® PS-II** shall be designed per local codes to prevent the entrance of water, insects or foreign materials.
11. Typical underground installations for corrugated stainless steel tubing include, but are not limited to:
  - Pool and spa heaters
  - School science laboratories
  - Gas service to outbuildings
  - Gas lampposts and grills

TABLE: 4-9

Minimum cover requirements for <b>TRACPIPE PS-II</b> , Burial in inches (cover is defined as the shortest distance measured between a point on top surface of the outer sleeve and the top surface of finished grade, concrete or similar cover)	
Location of buried <b>TracPipe PS-II</b>	Minimum cover for direct burial without concrete encasement
All locations not specified below	18 inches
In trench below 2-in thick concrete or equivalent	12 inches
Under a building with interior slab	4 inches
Under minimum of 4-in. thick concrete exterior slab with no vehicular traffic and the slab extending not less than 6-in beyond the underground installation	4 inches
Under streets, highways, roads, alleys, driveways, and parking lots	24 inches
One and two family dwelling driveways and parking lots and used only for dwelling-related purposes	18 inches
In or under airport runways, including adjacent areas where trespassing prohibited	18 inches

**Note:** When encased in concrete, the concrete envelope shall not be less than 2 inches thick.

### TracPipe PS-II Cut-Away

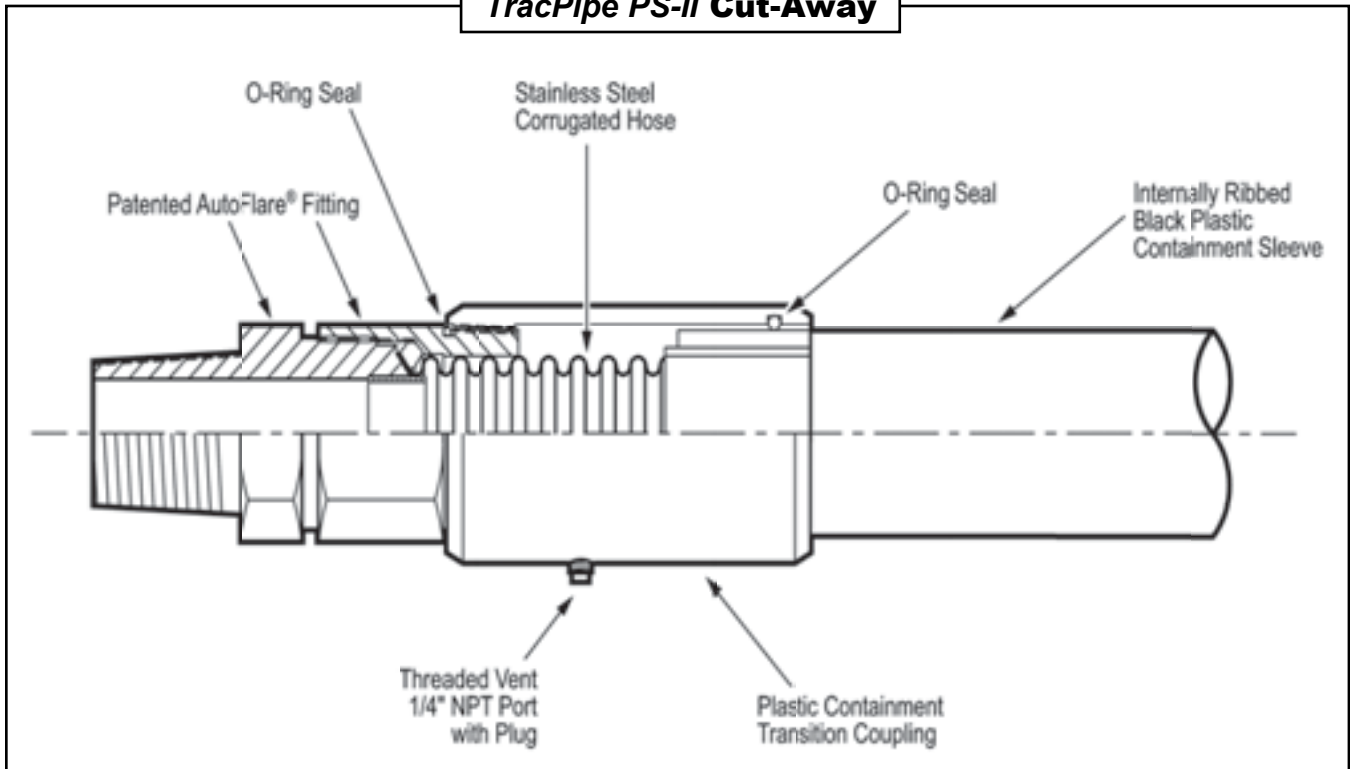

## SECTION 4.9B — TRACPIPE® PS-II

1. **TracPipe® PS-II** is a patented system suitable for above ground and underground use. It is designed with our standard CSST tubing and incorporates an internally ribbed sleeve (conduit), and specially designed end fittings that provide vent capability at either end of a piping run in the event of a leak in the CSST.
2. **TracPipe® PS-II** is IAPMO tested and UPC listed for underground use per IGC 201-2004, complies with all model code requirements for underground/under slab burial, and is CSA listed for above ground use.  
**NOTE:** The ANSI/CSA LC-1 Standard has no provisions for evaluating CSST for direct burial.
3. For above ground **PS-II** installations, the installer shall meet local building codes with respect to flame spread and smoke density regulations for nonmetallic materials. **PS-II** is not suitable for use in return air plenums or through penetration fire stop systems per UL classification requirements.
4. **TracPipe® PS-II** is supplied in standard lengths on reels or custom cut lengths. Standard reel lengths are 100, 150, and 250 feet (100 foot lengths for sizes up to 1 inch.)
5. **TracPipe® PS-II** lengths can be spliced together by using available couplings. All metallic portions of the fittings underground shall be mastic-wrapped to conform to local codes for under ground piping. Be certain prior to back-filling that no metallic portions of the piping system will be exposed to earth. **No fittings or couplings are permitted under building slabs.**
6. **NOTE:** When pressure testing **TracPipe® PS-II**, it is necessary to remove at least one fitting vent plug to insure proper test results on the stainless steel tubing. Codes do not require pressure testing of the sleeve. If local jurisdictions require the sleeve to be tested, do not exceed the pressure of the pipe (25 PSI maximum).

## SECTION 4.9C — TRACPIPE® PS-II FITTING ATTACHMENT

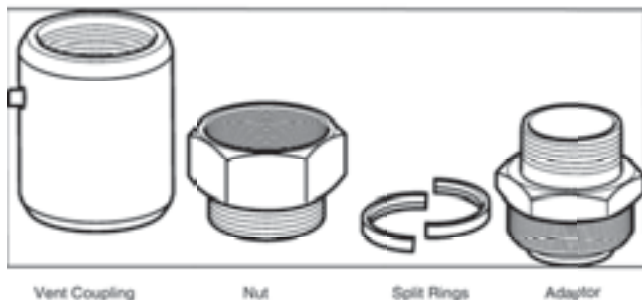

1. **TracPipe® PS-II** is constructed from **Omegaflex®** standard **TracPipe®** stainless steel flexible gas pipe sleeved in a fully vent-capable polyethylene sleeve.

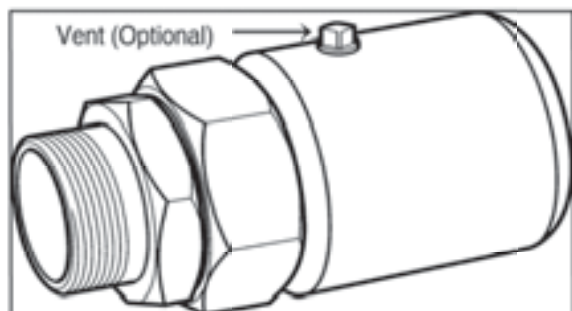

2. **TracPipe® PS-II** fittings are constructed from **TracPipe®** patented **AutoFlare®** fittings with a plastic containment coupling and 1/4 inch NPT vent port. Fittings assemble without special tools.
3. **NOTE:** When pressure testing **TracPipe® PS-II**, it is necessary to remove at least one fitting vent plug to insure proper test results on the stainless steel tubing.

### Tools Required for Assembly

- \* Utility knife with sharp blade
- \* Appropriate size Adjustable or Monkey Wrenches
- \* Tubing Cutter:

For up to 3/4" - #151 Ridgid® Tubing Cutter (FGP-TC-151) w/ TracPipe® Cutting Wheel (FGP-E-5272).

For 1" and up - #152 Ridgid® Tubing Cutter (FGP-TC-152) w/ TracPipe® Cutting Wheel (FGP-E-5272)

- \* Reciprocating Saw or Hacksaw

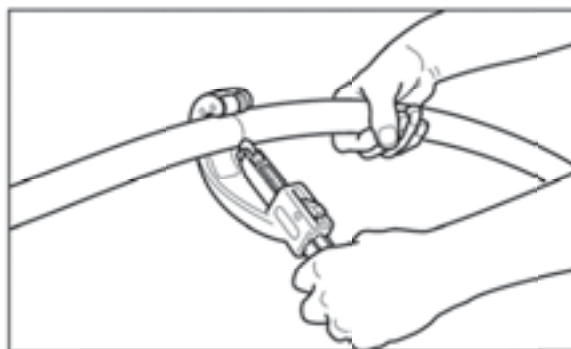

1. Unreel pipe into trench or on the ground and cut to desired length-plus one foot. Cutting up to 1 inch size can be done with a large tubing cutter. For 1-1/4 inch to 2 inch sizes, a reciprocating saw is recommended.

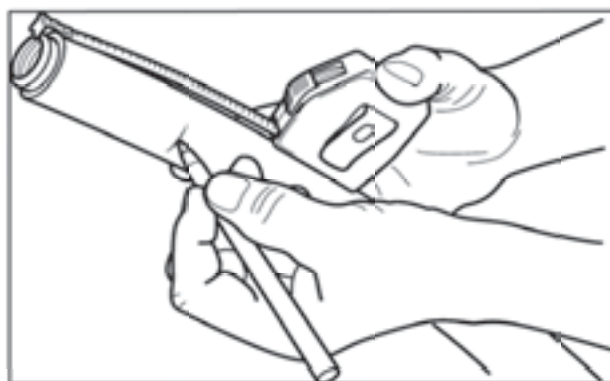

Table: 4-10

### **Jacket Strip Length / Fitting Torque / Superimposed Loading Chart**

Size	3/8	1/2	3/4	1	1-1/4	1-1/2	2
Jacket Strip Length	1-1/2"	1-1/2"	1-3/4"	2"	2-1/4"	2-1/2"	2-3/4"
Fitting Torque Value	40 ft-lb	42 ft-lb	45 ft-lb	75 ft-lb	150 ft-lb	200 ft-lb	250 ft-lb
OD for Core Hole Sizing	.820	1.08	1.32	1.6	1.96	2.18	2.8
Max. Superimposed Loading psf	9640	7254	5409	4203	3390	2901	2124

**Notes:** 1. Super-imposed loading includes all dead load and live load combinations.  
2. Maximum buried depth of 36"; 3. Soil Density : 120 pcf; 4. Factor of safety used: 4.

2. Mark the sleeve at specified length on the Strip Length Chart (Table: 4-10) - plus 2 inches.

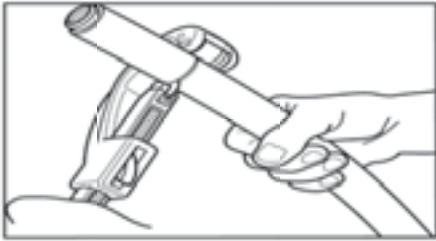

3. Using the appropriate tubing cutter with **TracPipe**® #FGP-E-5272 cutting wheel, score the black sleeve approximately half of the way through. Use extreme care not to cut or score the stainless corrugated pipe! Typically, no more than two turns in on the cutter is sufficient.

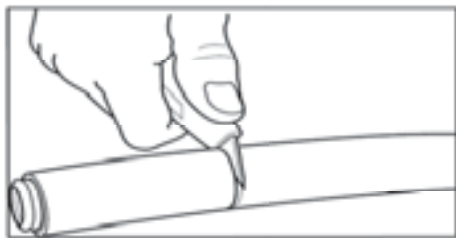

4. Finish cutting through the sleeve down to the stainless corrugated pipe using a sharp utility knife.

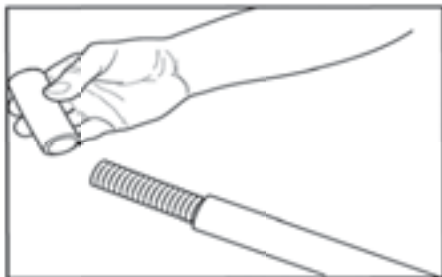

5. Using a twisting motion, remove the black sleeve from the pipe. It may be necessary to cut sleeve longitudinally and peel off for larger sizes. Inspect stainless pipe for scoring from the tubing cutter.

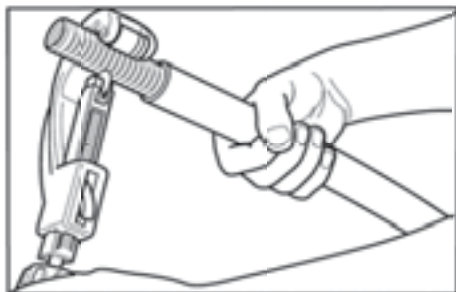

6. Using the tubing cutter, trim corrugated pipe to strip length specified in Table: 4.8. Cut slowly

in the root of the corrugation in the same manner you would cut copper tubing. Inspect end of pipe for a clean cut without tears in corrugation.



7. Remove adapter and split rings from fitting. Attach adapter to equipment. Slip coupling and nut over end of pipe all the way to expose first corrugations of pipe. Insert split rings into first corrugation as shown.

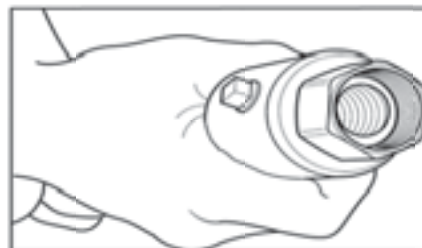

8. Holding the black coupling, slide fitting up to capture split rings into nut. Be sure split rings slip all the way to the base of the internal threads. Assembly is now ready to be attached to the adapter on the equipment.

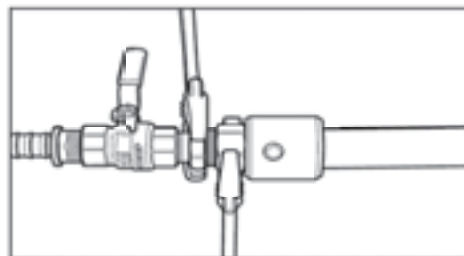

9. Thread nut onto adapter previously installed on the equipment. Using appropriate wrenches, hold adapter and tighten nut to proper torque specified.

Do not over tighten or use any pipe dope or thread sealants on this connection. This is a metal-to-metal seat and will not seal if pipe dope or thread sealants are used. Sealants are to be used on the NPT connection to the equipment only!

**NOTE:** When installing coupling FGP-UGC-SIZE the same instructions apply, except metallic parts of the fitting must be wrapped in a code approved manner (e.g. mastic used for wrapping metallic pipe).

## SECTION 4.10 — ELECTRICAL BONDING/ GROUNDING



### WARNING! FIRE / FUEL GAS PIPING

The *TracPipe*® flexible gas piping **MUST** be bonded to an effective ground-fault current path per the Canadian Electrical Code NFPA 54 in accordance with the instructions contained in this section.

It is **HIGHLY RECOMMENDED** to equipotentially bond all mechanical systems to the building's grounding electrode.

#### 1. Definitions:

**Grounding:** The process of making an electrical connection to the general mass of the earth. This is most often accomplished with ground rods, ground mats or some other grounding system. Low resistance grounding is critical to the operation of lightning protection techniques.

**Bonding:** The process of making an electrical connection between the grounding electrode and any equipment, appliance, or metal conductor: pipes, plumbing, flues, etc. Equipment bonding serves to protect people and equipment in the event of an electrical fault.

**Equipotential Bonding:** The process of making an electrical connection between the grounding electrode and any metal conductor: pipes, plumbing, flues, etc., which may be exposed to a lightning strike and can be a conductive path for lightning energy towards or away from the grounding electrode.

2. The *TracPipe*® gas piping system shall be bonded in accordance with these instructions, the Canadian Electrical Code and the Canadian B149.1 Code. In the event of a conflict between these instructions and local codes, the local codes shall control. The piping system is not to be used as a grounding conductor or electrode for an electrical system.

## SECTION 4.10A — TRACPIPE® COUNTERSTRIKE® CSST INSTALLATION INSTRUCTIONS

1. *CounterStrike*® CSST with the black, protective sleeve uses the same easy to install *AutoFlare*® fittings as conventional *TracPipe*® with the yellow jacket. *CounterStrike*® systems are sized in the same manner as *TracPipe*® either using capacity tables or other approved methods.
2. The instructions for cutting the tubing and for making fitting connections to *CounterStrike*® are identical to standard yellow-jacketed *TracPipe*®. The jacket shall remain intact as much as practical when attaching the fitting.
3. Unlike *TracPipe*®, there are no additional bonding requirements for *CounterStrike*® imposed by the manufacturer's installation instructions. However, *CounterStrike*® is to be bonded in accordance with the Canadian Electrical Code (C22.1) Section 10-406(4) in the same manner as the minimum requirements for copper water piping. However, installers must always adhere to any local requirements that may conflict with these instructions.
4. *CounterStrike*® meets building code requirements (ASTM E84) with respect to flame spread and smoke density. This permits installation in drop ceilings used as return air plenums.
5. *CounterStrike*® has thru penetration UL classifications for 1, 2 and 4 hours with the black jacket intact.

## SECTION 4.10B — BONDING CONVENTIONAL YELLOW-JACKETED TRACPIPE®

1. For bonding of the conventional yellow-jacketed **TracPipe**® system, a bonding clamp must be attached to the brass **AutoFlare**® fitting adapter (adjacent to the pipe thread area – See Figure: 4-25) or to a black pipe component (pipe or fitting) located in the same electrically continuous gas piping system as the **AutoFlare**® fitting. The corrugated stainless steel portion of the gas piping system SHALL NOT be used as the bonding attachment point under any circumstances. The bonding conductor shall be bonded per the Canadian Electrical Code (C22.1) Section 10-406(4).

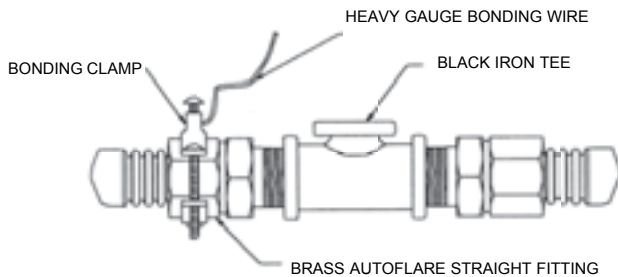

Figure: 4-25

### BRASS BONDING CLAMPS

Part No.	Fits <b>TracPipe</b> ® <b>AutoFlare</b> ® Fitting	Fits Iron Pipe Size
FGP-GC-1	3/8", 1/2"	1/2", 3/4", 1"
FGP-GC-2	3/4", 1", 1-1/4"	1-1/4", 1-1/2", 2"
FGP-GC-3	1-1/2", 2"	2-1/2", 3", 4"

**NOTE:** **TracPipe**® Bonding clamps have been tested and approved by CSA in accordance with UL 467 / CSA C22.2 No. 41-07 when installed on Black Iron / Galvanized steel pipe and **TracPipe**® **AutoFlare**® brass hex fittings (report #3000657, 5/2/08).

### IMPORTANT SAFETY PRECAUTION

- Failure to properly bond the conventional yellow-jacketed **TracPipe**® flexible gas piping may lead to damage to the CSST system in the event of a lightning strike.
  - The lightning may arc to or from another metal system, creating a hole in the wall of the **TracPipe**® CSST.
  - This presents a risk of fire in the building, and could lead to serious personal injury or significant property damage.
2. Lightning is a powerful and unpredictable natural force, and it has the capacity of damaging gas piping systems due to arcing between the gas piping system and other metallic systems in the building.
  3. If the building to be piped is in a high lightning flash density area or a region with a high number of thunderstorm days per year, (Figure: 4-26) consideration should be given to utilizing the Lightning Risk Assessment method given in Annex L of NFPA 780 for a determination of the need for a lightning protection system.

### NOTES:

- a. If possible, avoid running the bonding jumper a long distance through the building. The connection should be as short as possible. Gas meter should be near the electrical service if possible. If not, the bond can be connected at any point near the electrical service per Figure: 4-25.
- b. Lightning induced voltages seeking ground are subject to impedance; consider utilizing a braided or stranded bonding jumper for greater surface area, rather than solid wire.

- c. Upon completion of the conventional yellow-jacketed **TracPipe**® gas piping system installation and prior to gas service initiation, check to see if the bonding has been completed.
  
- d. Routing of gas piping should be as low in the structure as reasonably possible for best performance.





# CHAPTER 5

## INSPECTION, REPAIR AND REPLACEMENT

### SECTION 5.1 — MINIMUM INSPECTION REQUIREMENTS

#### TracPipe® Inspection Checklist

All installations shall be inspected by the jurisdiction having authority in accordance with provincial and local mechanical/plumbing codes and the Canadian CSA B149.1 Natural Gas and Propane Installation Code.

- Installer qualified per providence and/or local requirements.
- Installer has **TracPipe®** Training Certification card.
- Inspection and pressure test completed at rough in.
- Strike protection in place where required.
- TracPipe®** is bonded to the grounding electrode system.
- TracPipe®** tubing is supported at proper interval.

#### RECOMMENDED

- Installation of equipotential bonding between grounding electrode and all mechanical systems.

**TracPipe®** Flexible Gas Piping

**OMEGA FLEX® INC.**

451 Creamery Way, Exton, PA 19341-2509

Toll free: (800) 671-8622

Tel: (610) 524-7272

Fax: (610) 524-7282

## SECTION 5.2 — REPAIR OF DAMAGED PIPING

If the tubing is damaged, refer to the following sections to determine the severity of damage and, if necessary, the method of repair.

1. No repairs or replacement of the tubing is necessary if the tubing is only slightly dented due to impact or crushing as indicated in Figure: 5-1.
2. The tubing must be replaced under the following circumstances:
  - a. The tubing has been significantly crushed or dented (Figure: 5-2).
  - b. The tubing has been damaged by puncture of any kind, i.e., nails, screws, drill bits, etc.
  - c. The tubing has been bent beyond its minimum bend radius so that a crease or kink remains. (Figure: 5-3).

### METHOD OF REPAIR

A line splice can be made using an **AutoFlare** coupling, but if the tubing run is short and easily accessible, the preferred repair method is to replace the entire length. Tubing run can often be replaced faster than repairing the damaged section with a splice and this does not add any additional fitting joints to the system. The **AutoFlare**® fittings can be re-attached to the new tubing run

1. Where repairs or replacements involve corrugated stainless steel tubing systems of

different manufacturers, the systems can be joined again through standard pipe couplings and the appropriate CSST fittings. Figure: 5-4.



Figure: 5-1 – Repair Unnecessary. No Significant Damage to the Tubing Due to Impact or Crushing

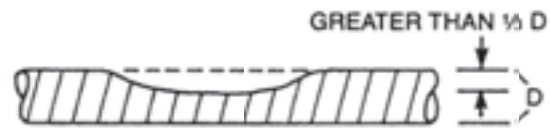

Figure: 5-2 – Repair Necessary. Significant Damage to the Tubing Due to Impact or Crushing

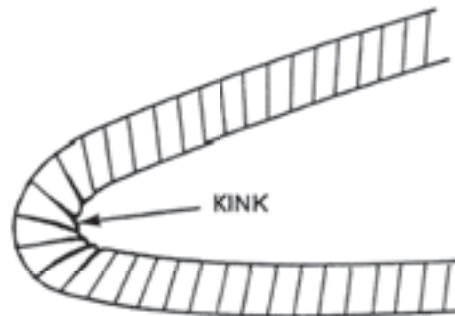

Figure: 5-3 – Repair Necessary. Damage Due to Bending Beyond Minimum Bend Radius

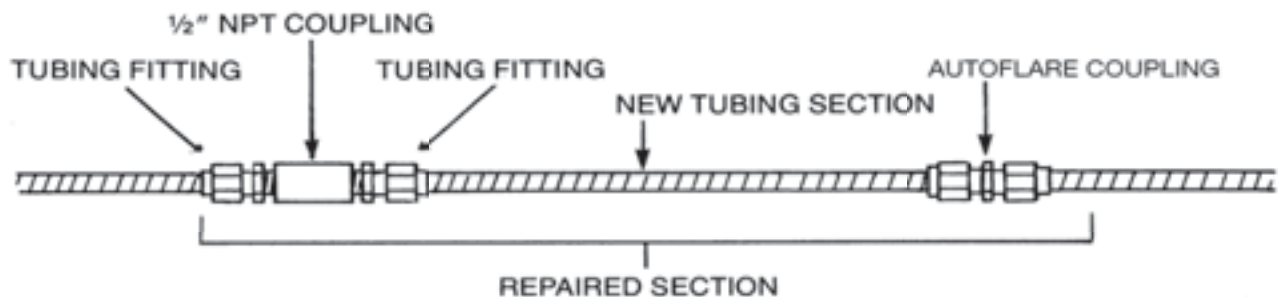

Figure: 5-4 – Repair of Damaged Tubing with a New Section of Tubing and a joint splice or an AutoFlare Coupling

# CHAPTER 6 PRESSURE/LEAKAGE TESTING

## SECTION 6.0 — PRESSURE TEST PROCEDURE

The final installation must be inspected and tested for leaks at 1-1/2 times the maximum working pressure, but not less than 3 PSI, using the procedures specified in Part 6.22 “Testing of Piping” of the CSA B149.1 Code. Pressure test according to these guidelines or to local codes. When local codes are more stringent, local codes must be followed. If no local codes apply, test according to the CSA B149.1 Code. The installer should never pressure test above 10 PSI with the pounds-to-inches regulator installed. This may damage the regulator.

1. Pressure testing should be performed during rough construction of the facility before interior walls are finished. This will permit a more complete inspection of the piping system during the pressure testing, and save costly rework in the event of leaks or other problems. *TracPipe*® is not responsible for repairs necessary to correct defects discovered after interior walls are finished.
2. Do not connect appliances or pressurize the system with fuel gas until after the pressure test is completed.
3. All gas outlets for appliance connections should be capped during pressure testing.

4. **USE ONLY NON-CORROSIVE LEAK CHECK SOLUTIONS.** Rinse with water and dry the tubing thoroughly after leak detection. (Available: *TracPipe*® Leak Check Solution P/N FGP-LCS).

5. Most utilities perform a leak test after setting the gas meter and prior to turning on the gas. This test is performed after the final construction is complete and finished interior walls are in place. This test is performed to assure no damage was done to the tubing during the closing-in construction process.

6. **NOTE:** When pressure testing *TracPipe*® *PS-II*, it is necessary to remove at least one fitting vent plug to insure proper test results on the stainless steel tubing. Codes do not require pressure testing of the sleeve. If local jurisdictions require the sleeve to be tested, do not exceed the pressure of the pipe (25 PSI maximum).

## SECTION 6.1 — Pressure Test for Elevated Pressure Systems

**NOTE: DO NOT SUBJECT *TracPipe*® SIZES 1-1/2 OR 2 INCH TO EXCESSIVE PRESSURE.**

Pressure test 1-1/2 inch and 2 inch sizes to local code requirements but not to exceed 40 PSI. In the absence of code requirements, test to 1-1/2 times actual working pressure, not to exceed 40 PSI.

The 2-5 PSI system requires a two-part pressure test. (See Figure: 6-1) The first part is performed on the elevated pressure section, between the meter connection and the pounds-to inches house line regulator.

The second part is performed on the low pressure section, between the pounds-to-inches house line regulator and the gas appliance outlet. If a steel pipe “jumper” is inserted in place of the house line regulator the entire system can be pressure tested in one step.

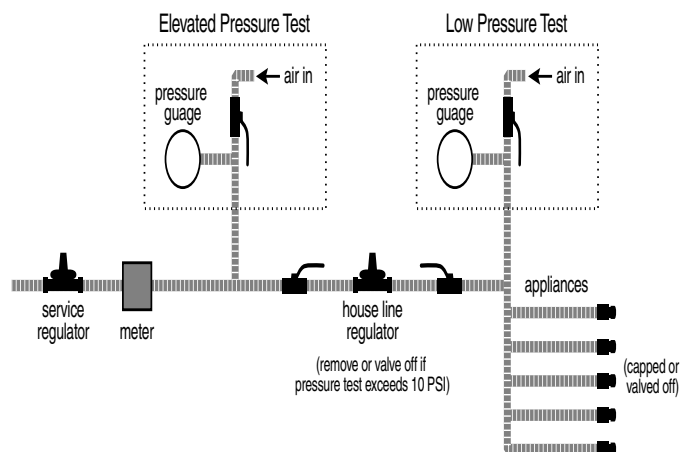

Figure: 6-1 – Pressure Test Requirement for a 2 PSI System

## **SECTION 6.1A — APPLIANCE CONNECTION LEAKAGE CHECK PROCEDURE**

1. After the final pressure test, inspection and final construction is complete (finished interior walls) connect the appliances to the tubing system.
2. This final connection can be accomplished by a stainless steel flexible connector, direct connection with CSST tubing or with rigid black pipe. See Section 4.6 for installation details and guidelines.
3. Turn the gas on at the meter and inspect for leakage before operating the appliances.
4. Connections made at the appliances should be leak checked with a bubble solution. Before placing the appliances in operation the tubing system should be purged. This displaces the air in the system with fuel gas. Be sure to bleed tubing system into a well ventilated area.

**NOTE:** Leak test solutions may cause corrosion to some types of material in the gas tubing system. Be sure to water rinse after the test and thoroughly dry all contacted material. Also, the vent limiter should not be leak tested with a liquid test solution. This will contaminate the internal ball check mechanism or plug the breathing hole, resulting in erratic regulator operation.

## **SECTION 6.1B — REGULATOR PERFORMANCE**

### **A. Load Response**

1. A performance test should be conducted while operating all appliances at full load.

This will insure adequate pressure to each appliance under full-load conditions. To accomplish this, measure the line pressure at the appliance connection while operating the appliance.

2. The inlet pressure for typical natural gas appliances should measure between 4 and 6 inches water column under full-load conditions. If this pressure can not be obtained a slight adjustment to the pounds-to-inches regulator may be necessary to increase the line pressure. Do not set any system regulator over the system design pressure (2 PSI).

### **B. Spring Adjustment**

1. The 2 PSI system pounds-to-inches house line regulator can be adjusted with an outlet pressure ranging between 7 and 11 inches of water column. The regulator must be adjusted according to the manufacturer's recommended procedure. A pressure gauge mounted just downstream of the regulator can monitor the set pressure under various loads.
2. The regulator is typically set when the system is operating at approximately 75 percent of maximum load.
3. The average natural gas appliance is designed to operate at 3 to 4 inches water column manifold pressure, and a pressure difference of 1 to 2 inches of water column across the appliance regulator which will prevent slow regulator response. Thus, the appliance regulator will operate best at 5 to 6 inches water column inlet pressure. In this case, the 2 PSI house line regulator should be reset to deliver approximately 8 to 10 inches of water column outlet pressure under load to allow for 3 inches of water column pressure drop in the tubing. Some appliances may have different inlet pressure requirements.

# CHAPTER 7 CAPACITY TABLES

## SECTION 7.0 — SIZING TABLES for *TracPipe*® Flexible Gas Piping

### STANDARD TABLES

#### Natural Gas:

<7 in. w.c. / 0.5 in. w.c. drop-	<b>Table N-1: Low Pressure</b> (Standard).....	Page 60
=> 7-14 in. w.c. / 1 in. w.c. drop-	<b>Table N-2: Medium Pressure</b> (1 inch drop).....	Page 60
2 PSI / 1 PSI drop-	<b>Table N-3: Elevated Pressure</b> (2 PSI).....	Page 61
5 PSI / 3.5 PSI drop-	<b>Table N-4: Elevated Pressure</b> (5 PSI).....	Page 61
20 PSI / 10 PSI drop-	<b>Table N-5: Elevated Pressure</b> (20 PSI).....	Page 62

#### Propane:

11-min / 1.0 in w.c. drop-	<b>Table P-1: Propane Low Pressure</b> .....	Page 62
2 PSI / 1 PSI drop-	<b>Table P-2: Propane Elevated Pressure</b> (2 PSI).....	Page 63
20 PSI / 10 PSI drop-	<b>Table P-3: Propane Elevated Pressure</b> (20 PSI).....	Page 63

**Table N-1 Low Pressure (Standard)**

Size EHD		Maximum Capacity of OmegaFlex TracPipe CSST in Cubic Feet per Hour (CFH) of Natural Gas (1000 BTU per cubic foot approx)																														
		Min. Gas Pressure: < 7 in w.c.																														
		Pressure Drop: 0.5 in w.c. (Based on a 0.60 Specific Gravity Gas)																														
		Tubing Length (feet)																														
		5	10	15	20	25	30	40	50	60	70	75	80	90	100	125	150	200	250	300	400	500	600	700	800	900	1000	1100	1200	1300	1400	1500
3/8"	15	63	45	37	33	29	27	23	21	19	18	17	17	16	15	14	12	11	10	9	8	7	6	6	5	5	5	4	4	4	4	4
1/2"	19	138	99	81	70	63	58	50	45	41	38	37	36	34	32	29	26	23	20	19	16	14	13	12	11	10	10	9	9	9	8	
3/4"	25	344	245	201	175	157	143	125	112	102	95	92	89	84	80	71	65	57	51	46	40	36	33	31	29	27	26	24	23	22	22	21
1"	31	589	419	343	298	267	244	212	190	174	161	156	151	142	135	121	111	96	86	79	68	61	56	52	48	46	43	41	40	38	37	35
1 1/4"	37	1109	789	646	561	503	460	399	358	327	303	283	284	268	254	228	208	181	162	148	128	115	105	97	91	86	82	78	75	72	69	67
1 1/2"	46	1790	1261	1027	888	793	723	625	559	509	471	455	440	415	383	351	320	277	247	226	195	174	159	147	137	129	123	117	112	107	103	100
2"	62	4142	2934	2398	2078	1860	1698	1472	1317	1203	1114	1076	1042	983	933	835	762	661	591	540	468	419	382	354	331	312	296	283	271	260	251	242

see notes below\*  
 EHD (Equivalent Hydraulic Diameter) A theoretical size which reflects the hydraulic performance of the tubing. It is not a true physical measure. This number is used to compare individual sizes between different manufacturers.  
 The higher the EHD number the greater the flow capacity of the piping.

**Table N-2 Medium Pressure (1 in drop)**

Size EHD		Maximum Capacity of OmegaFlex TracPipe CSST in Cubic Feet per Hour (CFH) of Natural Gas (1000 BTU per cubic foot approx)																														
		Min. Gas Pressure: >= 7-14 in w.c.																														
		Pressure Drop: 1.0 in w.c. (Based on a 0.60 Specific Gravity Gas)																														
		Tubing Length (feet)																														
		5	10	15	20	25	30	40	50	60	70	75	80	90	100	125	150	200	250	300	400	500	600	700	800	900	1000	1100	1200	1300	1400	1500
3/8"	15	87	63	52	45	41	37	33	29	27	25	24	23	22	21	19	17	15	14	12	11	10	9	8	8	7	7	7	6	6	6	6
1/2"	19	193	138	113	99	88	81	70	63	58	54	52	50	47	45	40	37	32	29	26	23	20	19	17	16	15	14	14	13	13	12	12
3/4"	25	482	344	282	245	220	201	175	157	143	133	129	125	118	112	100	92	80	71	65	57	51	46	43	40	38	36	34	32	31	30	30
1"	31	827	589	483	419	376	343	298	267	244	227	219	212	200	190	170	156	135	121	111	96	86	79	73	68	64	61	58	56	54	52	50
1 1/4"	37	1558	1109	908	789	707	646	561	503	460	426	412	399	377	358	320	293	254	228	208	181	162	148	137	128	121	115	110	105	101	97	94
1 1/2"	46	2541	1790	1458	1261	1126	1027	888	793	723	669	646	625	589	559	499	455	393	351	320	277	247	226	209	195	184	174	166	159	152	147	142
2"	62	5848	4142	3396	2934	2626	2398	2078	1860	1698	1573	1520	1472	1388	1317	1179	1076	933	835	762	661	591	540	500	468	441	419	399	382	367	354	342

\*Notes: Tables above include losses for four 90-degree bends and two end fittings. Tubing runs with larger numbers of bends and/or fittings shall be increased by the equivalent length of tubing to the following equation:  
 L = 1.3n where L is the additional length of tubing and n is the number of additional fittings and/or bends.

**Table N-3 Elevated Pressure 2 psig**

Size		Maximum Capacity of OmegaFlex TracPipe CSST in Cubic Feet per Hour (CFH) of Natural Gas (1000 BTU per cubic foot approx)																														
		Gas Pressure: 2 psig										Gas Pressure: 1.0 psig																				
		Pressure Drop: 1.0 psi (Based on a 0.60 Specific Gravity Gas)																														
		Tubing Length (feet)																														
		5	10	15	20	25	30	40	50	60	70	75	80	90	100	125	150	200	250	300	400	500	600	700	800	900	1000	1100	1200	1300	1400	1500
3/8"	15	410	353	286	246	220	200	172	154	139	128	124	120	112	107	94	87	75	67	61	53	47	43	40	38	36	34	33	31	30	29	28
1/2"	19	965	700	567	483	444	406	353	317	290	269	260	252	238	226	203	186	162	145	133	116	104	95	88	83	78	74	71	68	65	63	61
3/4"	25	2430	1734	1423	1237	1110	1015	883	792	724	672	650	630	595	565	507	464	403	361	331	287	258	236	219	205	193	184	175	168	162	156	151
1"	31	4220	3004	2463	2139	1917	1753	1522	1365	1248	1157	1118	1084	1023	971	871	796	691	620	567	492	441	403	374	350	330	314	299	287	276	266	257
1 1/4"	37	7969	5670	4646	4034	3615	3305	2870	2572	2352	2180	2108	2042	1927	1830	1640	1499	1302	1167	1067	926	830	759	703	659	622	590	563	540	519	500	484
1 1/2"	46	13626	9599	7820	6762	6041	5509	4763	4255	3881	3590	3467	3355	3161	2997	2678	2442	2111	1886	1720	1487	1329	1212	1121	1048	987	936	892	853	820	789	762
2"	62	30546	21637	17684	15326	13715	12526	10855	9715	8872	8217	7940	7689	7251	6881	6158	5624	4874	4362	3983	3452	3089	2821	2613	2445	2306	2188	2087	1998	1920	1851	1788

see notes below\*  
 EHD (Equivalent Hydraulic Diameter) A theoretical size which reflects the hydraulic performance of the tubing. It is not a true physical measure. This number is used to compare individual sizes between different manufacturers.  
 Pressure drop across a regulator will vary with flow rate. FGP-REC-3 has a 3/4 PSI pressure drop at a flow of 250 cubic feet per hour. regulator. The higher the EHD number the greater the flow capacity of the piping.  
 Table does not include effect of pressure drop across the line regulator. CAUTION: Capacities shown in table may exceed the maximum capacity for a selected regulator.

**Table N-4 Elevated Pressure 5 psig**

Size		Maximum Capacity of OmegaFlex TracPipe CSST in Cubic Feet per Hour (CFH) of Natural Gas (1000 BTU per cubic foot approx)																														
		Gas Pressure: 5 psig										Gas Pressure: 3.5 psig																				
		Pressure Drop: 3.5 psi (Based on a 0.60 Specific Gravity Gas)																														
		Tubing Length (feet)																														
		5	10	15	20	25	30	40	50	60	70	75	80	90	100	125	150	200	250	300	400	500	600	700	800	900	1000	1100	1200	1300	1400	1500
3/8"	15	736	672	552	475	420	382	329	293	267	246	238	230	216	205	182	166	143	128	116	100	89	78	73	68	65	62	59	57	54	53	51
1/2"	19	1769	1304	1040	905	827	755	654	586	532	493	479	463	437	415	373	341	297	266	244	212	190	174	162	152	143	136	130	125	120	116	112
3/4"	25	4472	3191	2619	2277	2042	1869	1625	1457	1333	1237	1196	1159	1095	1040	933	853	742	665	609	529	475	434	403	378	356	339	323	310	298	287	278
1"	31	7800	5659	4552	3953	3543	3240	2814	2522	2307	2139	2067	2003	1881	1795	1609	1472	1278	1146	1048	910	815	746	691	647	611	580	554	531	510	492	476
1 1/4"	37	14743	10489	8595	7463	6688	6116	5310	4759	4351	4034	3899	3778	3565	3386	3034	2774	2409	2159	1974	1714	1536	1404	1302	1219	1151	1093	1043	999	960	926	895
1 1/2"	46	25665	18080	14730	12737	11378	10377	8872	8015	7310	6762	6530	6320	5955	5646	5044	4600	3977	3553	3240	2802	2503	2283	2111	1974	1860	1763	1680	1608	1544	1487	1436
2"	62	56970	40353	32981	28383	25580	23361	20246	18119	16547	15326	14809	14341	13524	12634	11485	10489	9090	8135	7430	6439	5762	5262	4874	4561	4301	4081	3892	3727	3582	3452	3336

\*Notes: Tables above include losses for four 90-degree bends and two end fittings. Tubing runs with larger numbers of bends and/or fittings shall be increased by the equivalent length of tubing to the following equation:  
 L=1.3n where L is the additional length of tubing and n is the number of additional fittings and/or bends.

**Table N-5 Elevated Pressure 20 psig**

Size	EHD	Maximum Capacity of OmegaFlex TracPipe CSST in Cubic Feet per Hour (CFH) of Natural Gas (1000 BTU per cubic foot approx)																														
		Gas Pressure: 20 psig										Gas Pressure: 10.0 psig																				
		Pressure Drop: 10.0 psig (Based on a 0.60 Specific Gravity Gas)																														
		Tubing Length (feet)																														
		5	10	15	20	25	30	40	50	60	70	75	80	90	100	125	150	200	250	300	400	500	600	700	800	900	1000	1100	1200	1300	1400	1500
3/8"	15	1315	958	796	698	630	580	508	459	422	393	361	370	351	334	302	276	243	220	202	177	160	147	137	129	122	116	111	107	103	100	97
1/2"	19	3044	2214	1638	1610	1453	1336	1171	1057	972	905	877	851	807	768	693	638	559	504	464	406	367	337	314	295	280	266	255	245	236	228	221
3/4"	25	7190	5268	4391	3859	3491	3217	2827	2558	2357	2199	2132	2071	1965	1874	1695	1562	1373	1242	1144	1006	910	838	782	737	699	666	639	614	592	573	555
1"	31	12131	8910	7439	6545	5926	5464	4807	4353	4014	3747	3634	3531	3351	3197	2895	2669	2348	2126	1961	1725	1562	1440	1344	1267	1202	1147	1099	1058	1021	987	968
1 1/4"	37	18598	13773	11553	10199	9259	8556	7553	6857	6336	5926	5752	5593	5315	5078	4610	4259	3760	3414	3154	2784	2528	2336	2185	2062	1959	1872	1796	1730	1671	1618	1570
1 1/2"	46	33539	25802	21395	18733	16888	15533	13600	12268	11277	10502	10173	9874	9351	8907	8034	7385	6466	5833	5362	4695	4235	3883	3625	3408	3228	3074	2942	2826	2723	2632	2549
2"	62	65226	48577	40848	36123	32837	30375	26861	24418	22568	21147	20553	19974	18994	18158	16506	15269	13502	12274	11354	10040	9127	8443	7904	7466	7099	6787	6516	6278	6067	5878	5707

see notes below

EHD (Equivalent Hydraulic Diameter) A theoretical size which reflects the hydraulic performance of the tubing. It is not a true physical measure. This number is used to compare individual sizes between different manufactures. The higher the EHD number the greater the flow capacity of the piping. Table does not include effect of pressure drop across the regulator. User must size the regulator based on an inlet pressure between 10 and 20 psig with the desired outlet pressure range and capacity required.

**Table P-1 Propane Low Pressure**

Size	EHD	Maximum Capacity of TracPipe CSST in Thousands of BTU per Hour Propane Gas																														
		Min. Gas Pressure: 11-12 in w.c.										Min. Gas Pressure: 1.0 in w.c.																				
		Pressure Drop: 1.0 in w.c. (Based on a 1.52 Specific Gravity / 2520 BTU per cubic foot Gas)																														
		Tubing Length (feet)																														
		5	10	15	20	25	30	40	50	60	70	75	80	90	100	125	150	200	250	300	400	500	600	700	800	900	1000	1100	1200	1300	1400	1500
3/8"	15	138	100	82	71	65	59	52	46	43	40	38	36	35	33	30	27	24	22	19	17	16	14	13	13	11	11	11	9	9	9	9
1/2"	19	306	218	179	157	139	128	111	100	92	85	82	79	74	71	63	59	51	46	41	36	32	30	27	25	24	22	22	21	21	19	19
3/4"	25	763	545	446	388	348	318	277	249	226	211	204	196	187	177	158	146	127	112	103	90	81	73	68	63	60	57	54	51	49	47	47
1"	31	1309	933	765	663	595	543	472	423	386	359	347	336	317	301	269	247	214	192	176	152	136	125	116	108	101	97	92	89	85	82	79
1 1/4"	37	2467	1756	1438	1249	1119	1023	888	796	728	674	652	632	597	567	507	464	402	361	329	287	256	234	217	203	192	182	174	166	160	154	149
1 1/2"	46	4023	2834	2308	1997	1783	1626	1406	1256	1145	1059	1023	980	933	885	790	720	622	556	507	439	391	358	331	309	291	275	263	252	241	233	225
2"	62	9259	6558	5361	4645	4158	3797	3290	2945	2688	2490	2407	2331	2198	2085	1867	1704	1477	1322	1206	1047	936	855	792	741	698	663	632	605	581	560	541

\*Notes: Tables above include losses for four 90-degree bends and two end fittings. Tubing runs with larger numbers of bends and/or fittings shall be increased by the equivalent length of tubing to the following equation: L=1.3n where L is the additional length of tubing and n is the number of additional fittings and/or bends.



**Table P-2 Propane Elevated Pressure 2 psig**

Size	EHD	Maximum Capacity of TracPipe CSST in Thousands of BTU per Hour Propane Gas																														
		Min. Gas Pressure: <b>2 psig</b> Pressure Drop: <b>1.0 psi</b> (Based on a 1.52 Specific Gravity / 2520 BTU per cubic foot Gas)																														
		Tubing Length (feet)																														
		5	10	15	20	25	30	40	50	60	70	75	80	90	100	125	150	200	250	300	400	500	600	700	800	900	1000	1100	1200	1300	1400	1500
3/8"	15	649	558	453	389	347	316	271	243	220	203	196	189	177	169	144	137	118	105	96	84	74	68	63	60	57	54	49	47	46	44	
1/2"	19	1528	1106	898	781	701	643	559	502	459	426	412	399	377	358	321	294	256	230	211	184	165	150	139	131	123	117	112	108	103	100	97
3/4"	25	3847	2745	2253	1959	1757	1607	1398	1254	1146	1064	1029	997	942	895	803	735	638	572	524	454	408	374	347	325	306	291	277	266	256	247	239
1"	31	6881	4756	3900	3387	3035	2775	2410	2161	1976	1832	1770	1716	1620	1537	1379	1260	1094	982	898	779	698	638	592	554	522	497	473	454	437	421	407
1 1/4"	37	12617	8977	7356	6387	5724	5233	4544	4072	3724	3452	3338	3233	3051	2897	2597	2373	2061	1848	1669	1466	1314	1202	1113	1043	985	934	891	855	822	792	766
1 1/2"	46	21574	15198	12381	10706	9665	8722	7541	6737	6145	5684	5489	5312	5005	4745	4240	3866	3342	2986	2723	2354	2104	1919	1775	1659	1563	1482	1412	1351	1298	1249	1206
2"	62	48362	34257	27999	24285	21715	19832	17186	15381	14047	13010	12571	12174	11480	10894	9750	8804	7717	6906	6306	5465	4881	4466	4137	3871	3651	3464	3304	3163	3040	2931	2831

Notes: EHD (Equivalent Hydraulic Diameter) A theoretical size which reflects the hydraulic performance of the tubing. It is not a true physical measure. This number is used to compare individual sizes between different manufacturers. The higher the EHD number the greater the flow capacity of the piping. Table does not include effect of pressure drop across the line regulator. If the regulator loss exceeds 1/2 PSI (based on 11 inch outlet pressure). Do not use this chart. Pressure drops across a regulator will vary with flow rate. FGP-REG-SP has a 1/2 PSI pressure drop at a flow of 307 cubic feet per hour (774 MBTU/h). CAUTION: Capacities shown in the table may exceed the maximum capacity for a selected regulator.

**Table P-3 Elevated Pressure 20 psig**

Size	EHD	Maximum Capacity of OmegaFlex TracPipe CSST in Thousands of BTU per hour Propane Gas																														
		Gas Pressure: <b>20 psig</b> Pressure Drop: <b>10.0 psi</b> (Based on a 1.52 Specific Gravity / 2520 BTU per cubic foot Gas)																														
		Tubing Length (feet)																														
		5	10	15	20	25	30	40	50	60	70	75	80	90	100	125	150	200	250	300	400	500	600	700	800	900	1000	1100	1200	1300	1400	1500
3/8"	15	2082	1517	1260	1105	997	918	804	727	668	622	603	586	556	529	478	440	385	348	320	280	253	233	217	204	193	184	176	169	163	158	154
1/2"	19	4819	3505	2910	2549	2300	2115	1854	1674	1539	1433	1389	1347	1278	1216	1097	1010	885	798	735	643	581	534	497	467	443	421	404	388	374	361	350
3/4"	25	11384	8341	6952	6110	5527	5093	4476	4050	3732	3482	3376	3279	3111	2967	2684	2473	2174	1966	1811	1593	1441	1327	1238	1167	1107	1054	1012	972	937	907	879
1"	31	19207	14107	11778	10362	9382	8651	7611	6892	6355	5933	5754	5591	5306	5062	4584	4226	3718	3366	3105	2731	2473	2280	2128	2006	1903	1816	1740	1675	1617	1563	1517
1 1/4"	37	29446	21806	18291	16148	14659	13546	11958	10856	10032	9382	9107	8855	8415	8040	7299	6743	5953	5405	4994	4408	4003	3699	3459	3265	3102	2964	2844	2739	2646	2562	2486
1 1/2"	46	56268	40851	33874	29659	26754	24593	21532	19424	17855	16627	16107	15633	14805	14102	12720	11692	10237	9235	8489	7433	6705	6164	5739	5396	5111	4867	4658	4474	4311	4167	4036
2"	62	103429	76910	64673	57192	51990	48092	42528	38660	35763	33481	32509	31624	30073	28749	26133	24175	21377	19433	17976	15896	14450	13368	12514	11821	11240	10746	10317	9940	9606	9306	9036

Notes: Tables above include losses for four 90-degree bends and two end fittings. Tubing runs with larger numbers of bends and/or fittings shall be increased by the equivalent length of tubing to the following equation: L = 1.3n where L is the additional length of tubing and n is the number of additional fittings and/or bends.

## **SECTION 7.1 — PRESSURE DROP PER FOOT TABLES**

for *TracPipe* Flexible Gas Piping and Black Iron - Natural Gas

For propane (LP) gas applications:

1. Convert propane BTU load to CFH propane (divide by 2520 BTU per cubic foot).
2. Multiply CFH propane (1.52 SG) value by 1.5916 to obtain equivalent CFH Natural Gas (0.6 SG) value.
3. Find pressure drop per foot using CFH Natural Gas value from Step 2. This is the pressure drop per foot for Propane at the given BTU load.
4. Follow Sum of Pressure Loss instructions.

Convert 1,000 BTU values to CFH (Propane) using the formula:

$$\text{Propane} = 2520 \text{ BTU/Cu.Feet.}$$

**Section 7.1 - Table PD-1A**

**Pressure drop (inch wc per foot) for *TracPipe*® based on a given CFH Flow  
(Natural Gas SG = 0.60 Gas) at Inlet Pressures up to 5 PSI**

*Note: For Propane (LP) Gas applications, obtain Pressure Drop per foot values by following the Propane conversion method detailed in Section 7.1 of the TracPipe CounterStrike D&I Guide.*

CFH	3/8"	1/2"	3/4"	1"	1-1/4"	1-1/2"	2"
10	0.0019	0.0004	0.0001				
20	0.0085	0.0018	0.0003	0.0001			
30	0.0204	0.0042	0.0007	0.0002	0.0001		
40	0.0377	0.0077	0.0012	0.0004	0.0001	0.0001	
50	0.0609	0.0121	0.0019	0.0007	0.0002	0.0001	
60	0.0900	0.0177	0.0028	0.0009	0.0003	0.0001	
70	0.1253	0.0244	0.0038	0.0013	0.0004	0.0002	
80	0.1668	0.0321	0.0050	0.0017	0.0005	0.0002	
90	0.2146	0.0410	0.0064	0.0022	0.0006	0.0003	
100	0.2690	0.0509	0.0079	0.0027	0.0007	0.0003	0.0001
110	0.3300	0.0620	0.0096	0.0033	0.0009	0.0004	0.0001
120	0.3976	0.0743	0.0115	0.0039	0.0011	0.0005	0.0001
130	0.4721	0.0876	0.0135	0.0046	0.0013	0.0006	0.0001
140	0.5533	0.1022	0.0158	0.0053	0.0015	0.0006	0.0001
150	0.6415	0.1178	0.0182	0.0061	0.0017	0.0007	0.0001
160	0.7367	0.1347	0.0207	0.0070	0.0019	0.0008	0.0001
170	0.8389	0.1526	0.0235	0.0079	0.0022	0.0009	0.0002
180	0.9482	0.1718	0.0264	0.0089	0.0025	0.0011	0.0002
190	1.0647	0.1921	0.0295	0.0099	0.0028	0.0012	0.0002
200	1.1884	0.2136	0.0328	0.0110	0.0031	0.0013	0.0002
225	1.5297	0.2726	0.0418	0.0140	0.0039	0.0017	0.0003
250	1.9172	0.3390	0.0519	0.0174	0.0048	0.0020	0.0004
275	2.3517	0.4128	0.0631	0.0211	0.0058	0.0025	0.0004
300	2.8338	0.4943	0.0755	0.0252	0.0070	0.0029	0.0005
325	3.3642	0.5833	0.0890	0.0297	0.0082	0.0034	0.0006
350	3.9433	0.6799	0.1036	0.0345	0.0095	0.0040	0.0007
375	4.5717	0.7842	0.1193	0.0398	0.0110	0.0045	0.0008
400	5.2499	0.8962	0.1363	0.0454	0.0125	0.0052	0.0009
425	5.9783	1.0159	0.1543	0.0513	0.0142	0.0058	0.0010
450	6.7575	1.1434	0.1736	0.0577	0.0159	0.0065	0.0012
475	7.5877	1.2788	0.1940	0.0644	0.0178	0.0072	0.0013
500	8.4694	1.4219	0.2155	0.0715	0.0197	0.0080	0.0014
525	9.4030	1.5729	0.2382	0.0790	0.0218	0.0088	0.0016
550		1.7318	0.2621	0.0868	0.0240	0.0097	0.0017
575		1.8986	0.2872	0.0951	0.0262	0.0106	0.0019
600		2.0733	0.3134	0.1037	0.0286	0.0115	0.0021
625		2.2560	0.3408	0.1127	0.0311	0.0125	0.0022
650		2.4467	0.3694	0.1221	0.0337	0.0135	0.0024
675		2.6453	0.3992	0.1319	0.0364	0.0145	0.0026

**Section 7.1 - Table PD-1A**

**Pressure drop (inch wc per foot) for *TracPipe*® based on a given CFH Flow  
(Natural Gas SG = 0.60 Gas) at Inlet Pressures up to 5 PSI**

*Note: For Propane (LP) Gas applications, obtain Pressure Drop per foot values by following the Propane conversion method detailed in Section 7.1 of the TracPipe CounterStrike D&I Guide.*

CFH	1/2"	3/4"	1"	1-1/4"	1-1/2"	2"
700	2.8520	0.4301	0.1420	0.0392	0.0156	0.0028
725	3.0668	0.4623	0.1526	0.0421	0.0167	0.0030
750	3.2895	0.4956	0.1635	0.0451	0.0179	0.0032
775	3.5204	0.5302	0.1748	0.0482	0.0191	0.0034
800	3.7594	0.5659	0.1865	0.0514	0.0203	0.0037
825	4.0065	0.6028	0.1986	0.0547	0.0216	0.0039
850	4.2617	0.6410	0.2110	0.0582	0.0229	0.0041
875	4.5250	0.6803	0.2239	0.0617	0.0243	0.0044
900	4.7966	0.7208	0.2371	0.0653	0.0256	0.0046
925	5.0763	0.7625	0.2507	0.0691	0.0271	0.0049
950	5.3642	0.8055	0.2648	0.0729	0.0285	0.0052
975	5.6603	0.8496	0.2792	0.0769	0.0300	0.0055
1000	5.9647	0.8950	0.2940	0.0810	0.0316	0.0057
1100	7.2646	1.0885	0.3571	0.0983	0.0381	0.0070
1200	8.6972	1.3015	0.4264	0.1174	0.0453	0.0083
1300		1.5341	0.5020	0.1382	0.0531	0.0097
1400		1.7864	0.5839	0.1607	0.0615	0.0113
1500		2.0584	0.6722	0.1849	0.0705	0.0130
1600		2.3502	0.7668	0.2109	0.0801	0.0148
1700		2.6619	0.8677	0.2386	0.0903	0.0167
1800		2.9935	0.9750	0.2680	0.1011	0.0187
1900		3.3451	1.0887	0.2992	0.1125	0.0209
2000		3.7168	1.2088	0.3322	0.1245	0.0231
2100		4.1086	1.3353	0.3669	0.1371	0.0255
2200		4.5206	1.4682	0.4033	0.1503	0.0280
2300		4.9528	1.6075	0.4415	0.1641	0.0306
2400		5.4053	1.7533	0.4815	0.1786	0.0334
2500		5.8781	1.9056	0.5233	0.1936	0.0362
2600		6.3713	2.0643	0.5668	0.2092	0.0392
2700		6.8848	2.2295	0.6120	0.2254	0.0423
2800		7.4189	2.4011	0.6591	0.2422	0.0455
2900		7.9734	2.5793	0.7079	0.2597	0.0488
3000		8.5484	2.7640	0.7585	0.2777	0.0523
3100		9.1441	2.9552	0.8109	0.2963	0.0558
3200		9.7603	3.1529	0.8650	0.3155	0.0595
3300			3.3571	0.9210	0.3353	0.0633
3400			3.5679	0.9787	0.3557	0.0672
3500			3.7853	1.0382	0.3767	0.0712
3600			4.0091	1.0995	0.3983	0.0754
3700			4.2396	1.1626	0.4205	0.0797

**Section 7.1 - Table PD-1A**

**Pressure drop (inch wc per foot) for TracPipe® based on a given CFH Flow  
(Natural Gas SG = 0.60 Gas) at Inlet Pressures up to 5 PSI**

*Note: For Propane (LP) Gas applications, obtain Pressure Drop per foot values by following the Propane conversion method detailed in Section 7.1 of the TracPipe CounterStrike D&I Guide.*

CFH	1"	1-1/4"	1-1/2"	2"
3800	4.4766	1.2275	0.4433	0.0841
3900	4.7202	1.2941	0.4666	0.0886
4000	4.9704	1.3626	0.4906	0.0932
4100	5.2271	1.4329	0.5152	0.0979
4200	5.4905	1.5050	0.5403	0.1028
4300	5.7604	1.5788	0.5661	0.1078
4400	6.0370	1.6545	0.5924	0.1129
4500	6.3202	1.7320	0.6194	0.1181
4600	6.6100	1.8112	0.6469	0.1234
4700	6.9064	1.8923	0.6750	0.1289
4800	7.2094	1.9752	0.7037	0.1344
4900	7.5191	2.0599	0.7330	0.1401
5000	7.8355	2.1464	0.7629	0.1459
5250	8.6554	2.3706	0.8402	0.1610
5500	9.5170	2.6062	0.9212	0.1767
5750		2.8531	1.0059	0.1933
6000		3.1114	1.0943	0.2105
6250		3.3811	1.1864	0.2285
6500		3.6623	1.2821	0.2473
6750		3.9548	1.3815	0.2667
7000		4.2588	1.4846	0.2870
7250		4.5743	1.5913	0.3079
7500		4.9012	1.7017	0.3297
7750		5.2397	1.8158	0.3521
8000		5.5896	1.9335	0.3753
8250		5.9511	2.0549	0.3993
8500		6.3241	2.1799	0.4240
8750		6.7086	2.3086	0.4494
9000		7.1047	2.4409	0.4756
9250		7.5124	2.5769	0.5025
9500		7.9316	2.7166	0.5302
9750		8.3625	2.8598	0.5586
10000		8.8049	3.0067	0.5878
10500		9.7247	3.3115	0.6483

CFH	1-1/2"	2"
11000	3.6307	0.7119
11500	3.9645	0.7784
12000	4.3128	0.8479
12500	4.6756	0.9204
13000	5.0529	0.9959
13500	5.4447	1.0744
14000	5.8509	1.1559
14500	6.2716	1.2404
15000	6.7067	1.3278
16000	7.6202	1.5117
17000	8.5913	1.7077
18000	9.6200	1.9156
19000		2.1355
20000		2.3674
21000		2.6113
22000		2.8673
23000		3.1352
24000		3.4152
25000		3.7073
26000		4.0114
27000		4.3275
28000		4.6557
29000		4.9959
30000		5.3482
31000		5.7126
32000		6.0890
33000		6.4775
34000		6.8781
35000		7.2908
36000		7.7155
37000		8.1523
38000		8.6013
39000		9.0623
40000		9.5354

**Section 7.1 - Table PD-2A**

**Pressure drop (inch wc per foot) for Sch. 40 Metallic Pipe based on a given CFH Flow  
(Natural Gas SG = 0.60 Gas) at Inlet Pressures up to 5 PSI**

*Note: For Propane (LP) Gas applications, obtain Pressure Drop per foot values by following the Propane conversion method detailed in Section 7.1 of the TracPipe CounterStrike D&I Guide.*

CFH	1/2"	3/4"	1"	1-1/4"	1-1/2"	2"	2-1/2"	3"
10	0.0003	0.0001						
20	0.0009	0.0002	0.0001					
30	0.0020	0.0005	0.0002					
40	0.0033	0.0009	0.0003	0.0001				
50	0.0050	0.0013	0.0004	0.0001				
60	0.0071	0.0018	0.0006	0.0001	0.0001			
70	0.0094	0.0024	0.0007	0.0002	0.0001			
80	0.0120	0.0031	0.0009	0.0003	0.0001			
90	0.0149	0.0038	0.0012	0.0003	0.0001			
100	0.0181	0.0046	0.0014	0.0004	0.0002	0.0001		
110	0.0216	0.0055	0.0017	0.0005	0.0002	0.0001		
120	0.0254	0.0065	0.0020	0.0005	0.0003	0.0001		
130	0.0295	0.0075	0.0023	0.0006	0.0003	0.0001		
140	0.0338	0.0086	0.0027	0.0007	0.0003	0.0001		
150	0.0384	0.0098	0.0030	0.0008	0.0004	0.0001		
160	0.0433	0.0110	0.0034	0.0009	0.0004	0.0001	0.0001	
170	0.0484	0.0124	0.0038	0.0010	0.0005	0.0001	0.0001	
180	0.0538	0.0137	0.0043	0.0011	0.0005	0.0002	0.0001	
190	0.0595	0.0152	0.0047	0.0012	0.0006	0.0002	0.0001	
200	0.0654	0.0167	0.0052	0.0014	0.0006	0.0002	0.0001	
225	0.0813	0.0208	0.0064	0.0017	0.0008	0.0002	0.0001	
250	0.0988	0.0252	0.0078	0.0021	0.0010	0.0003	0.0001	
275	0.1178	0.0301	0.0093	0.0025	0.0012	0.0003	0.0001	0.0001
300	0.1384	0.0353	0.0109	0.0029	0.0014	0.0004	0.0002	0.0001
325	0.1605	0.0410	0.0127	0.0034	0.0016	0.0005	0.0002	0.0001
350	0.1840	0.0470	0.0146	0.0038	0.0018	0.0005	0.0002	0.0001
375	0.2091	0.0534	0.0165	0.0044	0.0021	0.0006	0.0003	0.0001
400	0.2356	0.0602	0.0186	0.0049	0.0023	0.0007	0.0003	0.0001
425	0.2635	0.0673	0.0208	0.0055	0.0026	0.0008	0.0003	0.0001
450	0.2929	0.0748	0.0232	0.0061	0.0029	0.0009	0.0004	0.0001
475	0.3237	0.0827	0.0256	0.0068	0.0032	0.0010	0.0004	0.0001
500	0.3559	0.0909	0.0282	0.0074	0.0035	0.0010	0.0004	0.0002
525	0.3896	0.0995	0.0308	0.0081	0.0039	0.0011	0.0005	0.0002
550	0.4246	0.1084	0.0336	0.0089	0.0042	0.0012	0.0005	0.0002
575	0.4609	0.1177	0.0365	0.0096	0.0046	0.0014	0.0006	0.0002
600	0.4987	0.1273	0.0394	0.0104	0.0049	0.0015	0.0006	0.0002
625	0.5378	0.1373	0.0425	0.0112	0.0053	0.0016	0.0007	0.0002
650	0.5783	0.1476	0.0457	0.0121	0.0057	0.0017	0.0007	0.0002
675	0.6201	0.1583	0.0490	0.0130	0.0061	0.0018	0.0008	0.0003

Tables calculated from Low-Pressure Gas Formula in NFPA -54

**Section 7.1 - Table PD-2A**

**Pressure drop (inch wc per foot) for Sch. 40 Metallic Pipe based on a given CFH Flow  
(Natural Gas SG = 0.60 Gas) at Inlet Pressures up to 5 PSI**

*Note: For Propane (LP) Gas applications, obtain Pressure Drop per foot values by following the Propane conversion method detailed in Section 7.1 of the TracPipe CounterStrike D&I Guide.*

CFH	1/2"	3/4"	1"	1-1/4"	1-1/2"	2"	2-1/2"	3"
700	0.6632	0.1693	0.0525	0.0139	0.0066	0.0019	0.0008	0.0003
725	0.7077	0.1807	0.0560	0.0148	0.0070	0.0021	0.0009	0.0003
750	0.7535	0.1924	0.0596	0.0157	0.0074	0.0022	0.0009	0.0003
775	0.8006	0.2044	0.0633	0.0167	0.0079	0.0024	0.0010	0.0003
800	0.8490	0.2168	0.0671	0.0177	0.0084	0.0025	0.0011	0.0004
825	0.8987	0.2295	0.0711	0.0188	0.0089	0.0026	0.0011	0.0004
850	0.9497	0.2425	0.0751	0.0198	0.0094	0.0028	0.0012	0.0004
875	1.0020	0.2559	0.0793	0.0209	0.0099	0.0029	0.0012	0.0004
900	1.0556	0.2695	0.0835	0.0221	0.0104	0.0031	0.0013	0.0005
925	1.1105	0.2835	0.0878	0.0232	0.0110	0.0033	0.0014	0.0005
950	1.1667	0.2979	0.0923	0.0244	0.0115	0.0034	0.0014	0.0005
975	1.2241	0.3125	0.0968	0.0256	0.0121	0.0036	0.0015	0.0005
1000	1.2828	0.3275	0.1015	0.0268	0.0127	0.0038	0.0016	0.0006
1100	1.5300	0.3907	0.1210	0.0320	0.0151	0.0045	0.0019	0.0007
1200	1.7972	0.4589	0.1421	0.0375	0.0178	0.0053	0.0022	0.0008
1300	2.0839	0.5321	0.1648	0.0435	0.0206	0.0061	0.0026	0.0009
1400	2.3901	0.6103	0.1890	0.0499	0.0236	0.0070	0.0030	0.0010
1500	2.7154	0.6933	0.2148	0.0567	0.0268	0.0080	0.0034	0.0012
1600	3.0596	0.7812	0.2420	0.0639	0.0302	0.0090	0.0038	0.0013
1700	3.4226	0.8739	0.2707	0.0715	0.0338	0.0101	0.0042	0.0015
1800	3.8043	0.9714	0.3009	0.0795	0.0376	0.0112	0.0047	0.0016
1900	4.2044	1.0735	0.3325	0.0878	0.0416	0.0124	0.0052	0.0018
2000	4.6228	1.1803	0.3656	0.0966	0.0457	0.0136	0.0057	0.0020
2100	5.0593	1.2918	0.4001	0.1057	0.0500	0.0149	0.0063	0.0022
2200	5.5139	1.4079	0.4361	0.1152	0.0545	0.0162	0.0068	0.0024
2300	5.9864	1.5285	0.4735	0.1251	0.0592	0.0176	0.0074	0.0026
2400	6.4766	1.6537	0.5122	0.1353	0.0640	0.0190	0.0080	0.0028
2500	6.9846	1.7834	0.5524	0.1459	0.0690	0.0205	0.0087	0.0030
2600	7.5100	1.9175	0.5940	0.1569	0.0742	0.0221	0.0093	0.0032
2700	8.0530	2.0562	0.6369	0.1682	0.0796	0.0237	0.0100	0.0035
2800	8.6133	2.1992	0.6812	0.1799	0.0851	0.0253	0.0107	0.0037
2900	9.1908	2.3467	0.7269	0.1920	0.0909	0.0270	0.0114	0.0040
3000	9.7856	2.4986	0.7740	0.2044	0.0967	0.0288	0.0121	0.0042
3100		2.6548	0.8223	0.2172	0.1028	0.0306	0.0129	0.0045
3200		2.8153	0.8721	0.2303	0.1090	0.0324	0.0137	0.0048
3300		2.9802	0.9232	0.2438	0.1154	0.0343	0.0145	0.0050
3400		3.1494	0.9756	0.2577	0.1219	0.0363	0.0153	0.0053
3500		3.3228	1.0293	0.2719	0.1286	0.0382	0.0161	0.0056
3600		3.5005	1.0843	0.2864	0.1355	0.0403	0.0170	0.0059
3700		3.6825	1.1407	0.3013	0.1426	0.0424	0.0179	0.0062
3800		3.8687	1.1984	0.3165	0.1498	0.0445	0.0188	0.0065
3900		4.0591	1.2573	0.3321	0.1571	0.0467	0.0197	0.0069

Tables calculated from Low-Pressure Gas Formula in NFPA -54

**Section 7.1 - Table PD-2A**

**Pressure drop (inch wc per foot) for Sch. 40 Metallic Pipe based on a given CFH Flow  
(Natural Gas SG = 0.60 Gas) at Inlet Pressures up to 5 PSI**

*Note: For Propane (LP) Gas applications, obtain Pressure Drop per foot values by following the Propane conversion method detailed in Section 7.1 of the TracPipe CounterStrike D&I Guide.*

CFH	3/4"	1"	1-1/4"	1-1/2"	2"	2-1/2"	3"
4000	4.2537	1.3176	0.3480	0.1647	0.0490	0.0207	0.0072
4100	4.4524	1.3792	0.3643	0.1724	0.0513	0.0216	0.0075
4200	4.6554	1.4421	0.3809	0.1802	0.0536	0.0226	0.0079
4300	4.8624	1.5062	0.3978	0.1882	0.0560	0.0236	0.0082
4400	5.0737	1.5716	0.4151	0.1964	0.0584	0.0246	0.0086
4500	5.2890	1.6383	0.4327	0.2048	0.0609	0.0257	0.0090
4600	5.5084	1.7063	0.4507	0.2133	0.0634	0.0268	0.0093
4700	5.7319	1.7755	0.4690	0.2219	0.0660	0.0278	0.0097
4800	5.9595	1.8460	0.4876	0.2307	0.0686	0.0290	0.0101
4900	6.1912	1.9178	0.5066	0.2397	0.0713	0.0301	0.0105
5000	6.4269	1.9908	0.5258	0.2488	0.0740	0.0312	0.0109
5250	7.0338	2.1788	0.5755	0.2723	0.0810	0.0342	0.0119
5500	7.6658	2.3746	0.6272	0.2968	0.0882	0.0372	0.0130
5750	8.3227	2.5780	0.6810	0.3222	0.0958	0.0404	0.0141
6000	9.0043	2.7892	0.7367	0.3486	0.1036	0.0437	0.0152
6250	9.7104	3.0079	0.7945	0.3759	0.1118	0.0472	0.0164
6500		3.2342	0.8543	0.4042	0.1202	0.0507	0.0177
6750		3.4680	0.9160	0.4334	0.1289	0.0544	0.0189
7000		3.7093	0.9798	0.4636	0.1378	0.0582	0.0203
7250		3.9580	1.0455	0.4947	0.1471	0.0621	0.0216
7500		4.2142	1.1131	0.5267	0.1566	0.0661	0.0230
7750		4.4776	1.1827	0.5596	0.1664	0.0702	0.0245
8000		4.7484	1.2542	0.5935	0.1765	0.0745	0.0259
8250		5.0265	1.3277	0.6282	0.1868	0.0788	0.0275
8500		5.3119	1.4031	0.6639	0.1974	0.0833	0.0290
8750		5.6044	1.4803	0.7004	0.2083	0.0879	0.0306
9000		5.9042	1.5595	0.7379	0.2194	0.0926	0.0323
9250		6.2111	1.6406	0.7763	0.2308	0.0974	0.0339
9500		6.5251	1.7235	0.8155	0.2425	0.1023	0.0357
9750		6.8462	1.8083	0.8556	0.2544	0.1074	0.0374
10000		7.1744	1.8950	0.8967	0.2666	0.1125	0.0392
10500		7.8520	2.0740	0.9813	0.2918	0.1231	0.0429
11000		8.5574	2.2603	1.0695	0.3180	0.1342	0.0468
11500		9.2907	2.4540	1.1612	0.3452	0.1457	0.0508
12000			2.6550	1.2563	0.3735	0.1576	0.0549
12500			2.8632	1.3548	0.4028	0.1700	0.0592
13000			3.0786	1.4567	0.4331	0.1828	0.0637
13500			3.3012	1.5620	0.4644	0.1960	0.0683
14000			3.5309	1.6707	0.4967	0.2096	0.0730
14500			3.7676	1.7827	0.5300	0.2237	0.0779
15000			4.0114	1.8981	0.5643	0.2382	0.0830

Tables calculated from Low-Pressure Gas Formula in NFPA -54



**Section 7.1 - Table PD-2A**  
**Pressure drop (inch wc per foot) for Sch. 40 Metallic Pipe based on a given CFH Flow**  
**(Natural Gas SG = 0.60 Gas) at Inlet Pressures up to 5 PSI**

*Note: For Propane (LP) Gas applications, obtain Pressure Drop per foot values by following the Propane conversion method detailed in Section 7.1 of the TracPipe CounterStrike D&I Guide.*

CFH	1-1/4"	1-1/2"	2"	2-1/2"	3"
16000	4.5200	2.1387	0.6359	0.2684	0.0935
17000	5.0563	2.3925	0.7113	0.3002	0.1046
18000	5.6201	2.6593	0.7907	0.3337	0.1163
19000	6.2112	2.9389	0.8738	0.3688	0.1285
20000	6.8293	3.2314	0.9608	0.4055	0.1413
21000	7.4742	3.5366	1.0515	0.4438	0.1546
22000	8.1457	3.8543	1.1460	0.4836	0.1685
23000	8.8437	4.1846	1.2442	0.5251	0.1829
24000	9.5680	4.5273	1.3461	0.5681	0.1979
25000		4.8823	1.4516	0.6126	0.2134
26000		5.2496	1.5608	0.6587	0.2295
27000		5.6292	1.6737	0.7063	0.2461
28000		6.0208	1.7901	0.7555	0.2632
29000		6.4245	1.9102	0.8061	0.2809
30000		6.8403	2.0338	0.8583	0.2990
31000		7.2679	2.1609	0.9120	0.3177
32000		7.7075	2.2916	0.9671	0.3369
33000		8.1589	2.4258	1.0238	0.3567
34000		8.6220	2.5635	1.0819	0.3769
35000		9.0969	2.7047	1.1415	0.3977
36000		9.5834	2.8494	1.2025	0.4189
37000			2.9975	1.2650	0.4407
38000			3.1490	1.3290	0.4630
39000			3.3040	1.3944	0.4858
40000			3.4624	1.4612	0.5091
41000			3.6242	1.5295	0.5329
42000			3.7894	1.5992	0.5572
43000			3.9579	1.6703	0.5819
44000			4.1299	1.7429	0.6072
45000			4.3051	1.8169	0.6330

## SECTION 7.2 — SIZING TABLE FOR STEEL PIPE

Natural Gas 0.5 PSI or less / 0.5 in. w.c. drop

**Table: SP-1**  
 Maximum Capacity of Pipe in Cubic Feet of Gas per Hour for Gas Pressures  
 of 0.5 PSI or Less and a Pressure Drop of 0.5 Inch Water Column (Based on a 0.6 Specific Gravity)

Normal Iron Pipe Size (Inches)	Internal Diameter (inches)	Length of Pipe (Feet)															
		10	20	30	40	50	60	70	80	90	100	125	150	175	200		
1/4	.364	43	29	24	20	18	16	15	14	13	12	11	10	9	8		
3/8	.493	95	65	52	45	40	36	33	31	29	27	24	22	20	19		
1/2	.622	175	120	97	82	73	66	61	57	53	50	44	40	37	35		
3/4	.824	360	250	200	170	151	138	125	118	110	103	93	84	77	72		
1	1.049	680	465	375	320	285	260	240	220	205	195	175	160	145	135		
1 1/4	1.380	1,400	950	770	660	580	530	490	460	430	400	360	325	300	280		
1 1/2	1.610	2,100	1,460	1,180	990	900	810	750	690	650	620	550	500	460	430		
2	2.067	3,950	2,750	2,200	1,900	1,680	1,520	1,400	1,300	1,220	1,150	1,020	950	850	800		
2 1/2	2.469	6,300	4,350	3,520	3,000	2,650	2,400	2,250	2,050	1,950	1,850	1,650	1,500	1,370	1,280		
3	3.068	11,000	7,700	6,250	5,300	4,750	4,300	3,900	3,700	3,450	3,250	2,950	2,650	2,450	2,280		
4	4.026	23,000	15,800	12,800	10,900	9,700	8,800	8,100	7,500	7,200	6,700	6,000	5,500	5,000	4,600		

## CHAPTER 8

### DEFINITION OF TERMINOLOGY

**A.G.A.** – American Gas Association

**ANSI Z223.1 1988** – 1988 edition of the National Fuel Gas Code published by American National Standard Institute. Also known as NFPA 54 (National Fire Protection Association).

**Appliance** (Equipment) – Any device which utilizes natural gas or propane as a fuel or raw material to produce light, heat, power, refrigeration or air conditioning.

**Approved** – Acceptable to the authorities having jurisdiction.

**Authority Having Jurisdiction** – The organization, office or individual responsible for “approving” equipment, an installation or a procedure.

**BTU** – Abbreviation for British Thermal Unit, which is the quantity of heat required to raise the temperature of one pound of water one degree Fahrenheit .

**CFH** – Gas flow rate stated in cubic feet per hour.

**Clothes Dryer** – A device used to dry wet laundry by means of heat derived from the combustion of natural gases.

**Design Pressure** – The maximum operating pressure permitted by this document, as determined by the design procedures applicable to the materials involved.

**Drip Leg** – The container (dirt trap pocket) placed at a low point in a system of piping to collect foreign material or condensate and from which it may be removed.

**EHD (Effective Hydraulic Diameter)** – A relative measure of Flow Capacity; This number is used to compare individual sizes between different manufacturers. The higher the EHD number the greater flow capacity of the piping.

**Full Lockup** – The capability of totally stopping the flow of gas if the load goes to zero, thus preventing the downstream pressure from increasing more than a certain upper limit pressure above the set point.

**Header** (Manifold) – A pipe or fitting to which a number of branch lines are connected.

**ID** – Inside diameter of pipe or tubing.

**Inches (“) W.C.** – Method of stating pressure measured in inches of water column by a manometer or pressure gauge. Commonly used in the gas industry when the pressure is less than one (1) PSI.

**1 PSI** = 28 inch W.C. approximately

**1/2 PSI** = 14 inch W.C.

**1/4 PSI** = 7 inch W.C.

**Load** – The amount of gas in Cfh required by an appliance, or group of appliances, per their rating plate.

**L. P. Gas** – Fuel gas that is stored and transported in a liquid state, i.e., propane, butane, and mixtures of these and other heavier hydrocarbons.

**Meter** – An instrument installed to measure the volume of gas delivered through a piping system.

**Manometer** – A “U” shaped tube filled with water, or mercury where the pressure applied to one leg of the “U” will push the liquid column a measurable distance. Also known as a “U” gauge.

**OD** – Outside Diameter of pipe or tubing.

**1/2 PSI** – A shortened way of stating 1/2 pounds per square inch gauge. Also the name of a low pressure piping system supplying gas from the meter at 1/2 PSI to each appliance pressure regulator.

**Piping** – As used in this document, either pipe or tubing, or both.

- a. pipe – Rigid conduit of iron, steel, copper, brass or aluminum.
- b. tubing – Semi rigid conduit of corrugated stainless steel.

**Pressure** – Unless otherwise stated, is expressed in pounds per square inch above atmospheric pressure, i.e. gage pressure (PSI).

**Pressure Drop** – The loss in static pressure of gas due to friction or obstruction in tubing, valves, fittings, regulators and burners.

**Pressure Regulator** – A valve which reduces and controls pressure. It automatically opens and closes in response to changing pressure conditions in the downstream piping.

**PSI** – Pounds per square inch gauge. The pressure, as read from a measurement gage or device. Gauge pressure is pressure above atmospheric pressure.

**Purge** – To displace the original air, or gas, or a mixture of gas and air in a gas conduit with a new air/gas mixture.

**Regulator, Appliance (inches w.c. – inches w.c.)** – A device for controlling and maintaining a uniform pressure to the manifold of gas burning equipment. This valve is typically part of the appliance. It reduces the pressure from 5.5 inch w.c. to the manifold pressure in the appliance. (approximately 3.5 inch w.c.).

**Regulator, House Line (PSI – inches w.c.)** – A device placed in a gas line between the service regulator and the appliance regulator for controlling, maintaining or reducing the pressure in that portion of the piping system downstream of the device. This valve reduces the house line pressure (Typically 2 PSI) to the regulator manifold pressure (Typically 8-10 inch w.c.).

**Regulator, Service (PSI – PSI or inches w.c.)** – A device installed by the serving gas supplier to reduce and limit the service line gas pressure. This valve reduces the service pressure to the metering pressure. It is located upstream of the gas meter.

**Regulator Vent** – The opening in the atmospheric side of the regulator housing permitting the in and out movement of air to compensate for the movement of the regulator diaphragm.

**Specific Gravity** – As applied to gas, the ratio of the weight of a given volume to that of the same volume of air, both measured under the same conditions.

**2 PSI** – A shortened way of stating 2 pounds per square inch gauge pressure. Also the name of a piping system supplying gas at 2 PSI to a house line regulator which then reduces the pressure to inches W.C. upstream of the appliance regulator.

**Valve, Manual Shut-off** – A valve (located in the piping system and readily accessible and operable by the consumer) used to shut off individual equipment.

**Vent Limiter Device** – Restriction/orifice type device in the vent outlet of a pressure regulator that controls or limits leakage, in the event of a diaphragm leak. It also allows the diaphragm to move freely to control pressure.

# APPENDIX A UL CLASSIFICATION

The UL Through Penetration Firestop Systems in Appendix A are only a sample of the complete UL database. See following page.

## System No. W-J-1106

**F-Rating - 1 & 2 Hr**  
**T-Rating - 3/4 and 1-1/4 Hr**

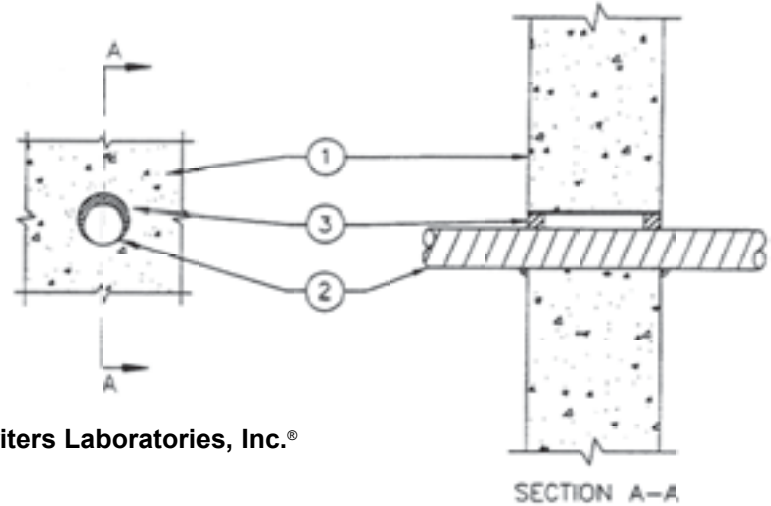

Underwriters Laboratories, Inc.®

- 1. Wall Assembly-** Min 4-7/8 in. or 6-1/8 in. thick lightweight or normal weight (100-150 pcf) concrete for 1 or 2 hr rated assemblies, respectively. Wall may also be constructed of any UL Classified **Concrete Blocks\***. Max diam of opening is 3-1/2 in.  
See **Concrete Blocks** (CAZT) category in the Fire Resistance Directory for names of manufacturers.
- 2. Through Penetrating Products\*-Flexible Metal Piping-**Nom. 2 in. diam (or smaller) steel flexible metallic piping. Max one flexible metal piping to be installed either concentrically or eccentrically within opening. The annular space between piping and periphery of opening shall be min 0 (point contact) in. to max 1 in. Piping to be rigidly supported on both sides of wall assembly. Plastic covering on piping may or may not be removed on both sides of wall assembly.  
**Omegaflex Inc.**—TracPipe **Flexible Gas Piping**.
- 3. Fill, Void, or Cavity Material\*-Sealant** -Min. 5/8 and 1 in. thickness of fill material for 1 and 2 hr fire-rated wall assemblies, respectively, applied within the annulus, flush with both surfaces of wall. An additional 1/2 in. diam of fill material applied at gypsum board/penetrant interface at point contact location on both surfaces of wall.  
**Johns Manville International, Inc.** — Firetemp™ CI

\*Bearing the UL Classification Marking

## SYSTEM No. C-AJ-1340

**Floor or Wall Assembly-**Min 4-1/2 in. thick lightweight or normal weight (100 to 150 pcf) concrete. Wall may also be constructed of any UL Classified **Concrete Blocks\***. Diam of opening in floor or wall assembly to be min 3/4 in. to max 1-1/2 in. Larger than diam of flexible metal piping (Item 2) installed in through opening. Max diam of opening is 4 in. See Concrete Block (CAZT) category in the Fire Resistance Directory for names of manufacturers.

**Through-Penetrant\*-Omegaflex Gas Piping**—Nom 2 in. diam (or smaller) flexible gas piping. One flexible gas piping to be installed either concentrically or eccentrically within the firestop system. The annular space between gas piping and periphery of opening shall be min 0 in. (point contact) to max. 1-1/2 in. Gas piping to be rigidly supported on both sides of floor or wall assembly. Plastic covering on piping may or may not be removed on both sides of floor or wall assembly. **OmegaFlex, Inc.**-TracPipe Flexible Gas Piping

**Firestop System** The firestop system shall consist of the following:

**A. Packing Material**-Min 3-3/4 in. thickness of min 4 pcf mineral wool batt insulation firmly packed into opening as a permanent form. Packing material to be recessed from top surface of floor or from both surfaces wall as required to accommodate the required thickness of fill material.

**B. Fill, Void or Cavity Material\* -Sealant** Min 3/4 in. thickness of fill material applied within the annulus, flush with top surface of floor or both surfaces of wall. Min 1/2 in. diam bead of caulk applied to the penetrant/concrete or penetrant/concrete interface at the point contact location between penetrant and periphery of opening.

**Passive Fire Protection Partners**--4800DW

\* Bearing the UL Classification Marking

**XHEZ**  
Through Penetration Firestop systems

**System No. C-AJ-1340**  
**F-Rating - 4 Hr**  
**T-Rating - 2 1/4 Hr**

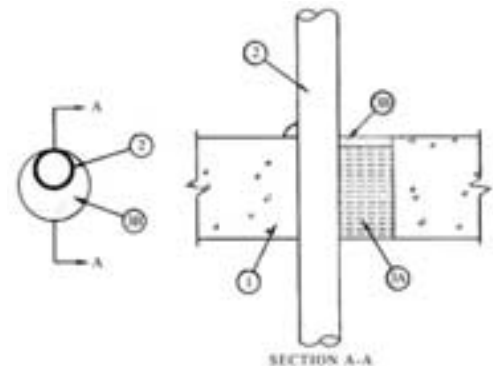

Underwriters Laboratories, Inc.®

# UL CLASSIFICATION

## SYSTEM NO. W-L-1195

The UL Through Penetration Firestop Systems in Appendix A are only a sample of the complete UL database. See NOTE below.

**1. Wall Assembly-** The 1 or 2 hr fire rated gypsum wallboard/stud wall assembly shall be constructed of the materials and in the manner described in the individual U300 or U400 Series Wall and Partition Designs in the UL Fire Resistance Directory and shall include the following construction features:

**A. Studs-** Wall framing may consist of either wood studs or steel channel studs. Wood studs to consist of nom 2 by 4 in. lumber spaced 16 in. OC with nom 2 by 4 in. Lumber end plates and cross braces. Steel studs to be min 3-5/8 in. wide by 1-3/8 in. deep channels spaced max 24 in. OC.

**B. Wallboard, Gypsum\*-** Thickness, type, number of layers and fasteners as required in the individual Wall and Partition Design. Max diam of opening is 3-1/2 in.

**XXEZ**  
**Through-Penetration Firestop Systems**  
**System No. W-L-1195**  
**F Rating - 1 & 2 hr (See Item 1)**  
**T Rating - 3/4 & 1-1/4 hr(See Item 1)**

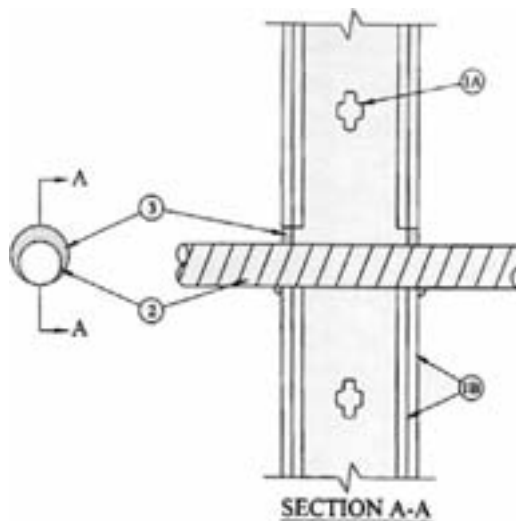

Underwriters Laboratories inc.®

**1. The hourly F rating of the firestop system is equal to the hourly fire rating of the wall assembly in which it is installed. The hourly T rating is 3/4 hr and 1-1/4 hr for 1 and 2 hr rated assemblies, respectively.**

**2. Through-Penetrating Product\*-**Flexible Metal Piping-Nom 2 in. diam (or smaller) steel Flexible Metal Piping. Max one flexible metal piping to be installed either concentrically or eccentrically within opening. The annular space between pipe and periphery of opening shall be min 0 in. (point contact)to max 1 in. Piping to be rigidly supported on both sides of wall assembly. Plastic covering on piping may or may not be removed for a distance of 2 feet. on both sides of wall assembly. **OmegaFlex, Inc.- TracPipe Flexible Gas Piping**

**3. Fill, Void, or Cavity Material\*-Sealant** - Min 5/8 and 1 in. thickness of fill material for 1 and 2 hr fire-rated wall assemblies, respectively, applied within the annulus, flush with both surfaces of wall. An additional 1/2 in diameter of fill material applied at gypsum board/penetrant interface at point contact location on both surfaces of wall.

**Johns Manville International, Inc** - Firetemp™CI

\*Bearing the UL Classification Marking

**NOTE:** to access the complete UL Through Penetration Firestop Systems database online:

1. Go to website [www.ul.com](http://www.ul.com)
2. Click on : "CERTIFICATIONS" in left hand panel
3. Click on : "Company name/location" under General Search
4. Fill in OmegaFlex inc (3 words) in "Company Name" box
5. All approved systems are shown



**F Rating - 1 and 2 Hr (See Item 1)**  
**T Rating - 1 Hr**

F-C-1111

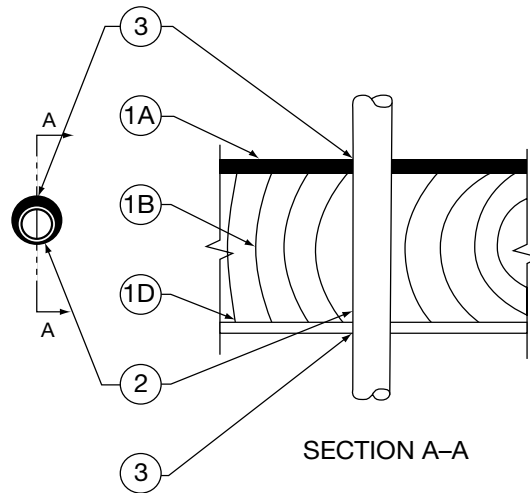

1. **Floor Assembly** - The 1 or 2 hr fire-rated wood joist, wood truss or combination wood and steel truss Floor-Ceiling assembly shall be constructed of the materials and in the manner described in the individual L500 Series Design in the UL Fire Resistance Directory. **The F Rating of the firestop system is equal to the rating of the floor-ceiling and wall assemblies.** The general construction features of the floor-ceiling assembly are summarized below:
  - A. **Flooring System** - Lumber or plywood subfloor with finish floor of lumber, plywood or **Floor Topping Mixture\*** as specified in the individual Floor-Ceiling Design. Max diam of opening is 3 in. (76 mm).
  - B. **Joists** - Nom 2 by 10 in. (51 by 254 mm) deep (or deeper) lumber joists spaced 16 in. (406 mm) OC or steel or combination lumber and steel joists, trusses or **Structural Wood Members\*** with bridging as required and with ends firestopped.
  - C. **Furring Channels** (Not Shown) (As required) Resilient galvanized steel furring installed in accordance with the manner specified in the individual L500 Series Designs in the Fire Resistance Directory.
  - D. **Gypsum Board\*** - Thickness, type, number of layers and fasteners shall be as specified in the individual Floor-Ceiling Design. Max diam of opening is 3 in. (76 mm).
2. **Through Penetrating Products\*** - **Flexible Metal Piping**-Nom 2 in. (51 mm) diam (or smaller) steel Flexible Metal Piping with or without plastic covering on piping. Max one flexible metal piping to be installed near center of circular through opening in floor assembly. The annular space between the piping and periphery of opening shall be min 0 in. (0 mm) (point contact) to max 1/2 in. (13 mm). Piping to be rigidly supported on both sides of floor assembly.
3. **Fill, Void or Cavity Material\* - Sealant** - Min 3/4 in. (19 mm) thickness of sealant applied within annulus on top surface of floor. Min 5/8 in. (16 mm) thickness of sealant applied within annulus on bottom surface of ceiling. At point contact location, a min 1/2 in. (13 mm) bead of sealant shall be applied to the penetrant/gypsum board interface on bottom surface of ceiling and at penetrant/flooring interface on top surface of floor.

**Passive Fire Protection Partners\*\*** - 3600EX, 41GONS or 4800DW

\*Bearing the UL Classification Marking

\*\*Formerly Firestop Systems Inc.



**Underwriters Laboratories Inc.®**

09/03

## **APPENDIX B**

### **MANUFACTURED HOUSING GUIDELINES**

#### A. PIPING SYSTEM DESIGN REQUIREMENTS

1. The primary information for any **TracPipe**<sup>®</sup> installation is contained in the **TracPipe**<sup>®</sup> *Design Guide and Installation Instructions* (latest edition). This guide provides manufacturer's instructions that are a requirement of the ANSI/CSA LC-1 Standard governing certification and test requirements for Corrugated Stainless Steel Tubing. Manufacturer's instructions must be followed.
2. Sizing for gas piping systems in mobile homes must be performed in accordance with Section 3.2 of this guide. System sizing is to be done with Low Pressure Capacity Charts utilizing 0.5-inch water column drop. (See Table: N-1 in the **TracPipe**<sup>®</sup> Design Guide).
3. The natural gas supply connections shall not be less than the size of the gas piping but shall not be smaller than 3/4-inch nominal pipe size. Gas supply connection shall not be beneath an exit door. Gas supply connection shall be rigidly anchored to a structural member within 6 inches of supply connection. All exterior openings around piping shall be sealed to resist the entrance of rodents.
4. Where fuel gas piping is to be installed in more than one section of an expandable or multiple-unit home, crossover connections between sections of the home shall be constructed by one of the following methods:
  - A. Listed quick disconnect device, designed to provide a positive seal of the supply side of the gas piping system when such device is separated.
  - B. Connections to meters shall comply with local requirements.
  - C. Direct plumbing (CSST) sized in accordance with Natural Gas Low Pressure Capacity Table: N-1 (See Table: N-1 in the **TracPipe**<sup>®</sup> Design Guide).
5. The flexible connector, direct plumbing pipe or "quick-disconnect" device shall be provided with protection from mechanical and impact damage and located to minimize the possibility of tampering. For gas line crossover connections made with CSST or flexible connectors, the crossover points shall be capped on the supply side to provide a positive seal and covered on the other side with a suitable protective covering.
6. All points of crossover shall be accessible from the exterior of the home.

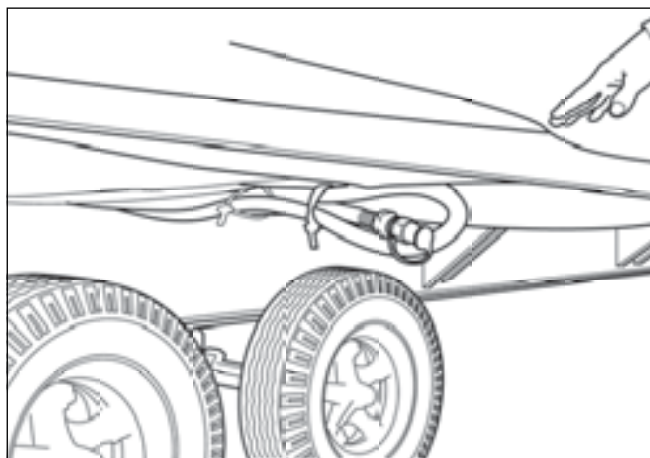



## B. INSTALLATION REQUIREMENTS

1. The preferred location for CSST flexible gas piping is beneath the floor and inside or above the I-beam flange. This location will provide the best protection from transit damage. Appliance stub-outs are easily made utilizing termination mounts or flange mounts rigidly attached to the floor. Final connections can be made with approved flexible appliance connectors downstream from the appliance shut-off valve. All floor penetrations shall be sealed to resist the entrance of rodents. All CSST should be within the envelope or rigidly attached to the I-beam flange.
2. Where CSST must cross an I-beam flange, the piping shall be securely attached to the house flange to protect the CSST. Angle iron, C-channel or a wooden block are recommended means of attachment. It is preferred to drill through a wooden structural member if possible to avoid crossing the flange.
3. In open joist construction, routing should be within the open web portion of the fabricated joist wherever possible. This location provides necessary support points at each joist location.
4. In all locations, CSST must be supported in accordance with the manufacturer's instructions (every 4 feet-3/8 size, 6 feet-1/2 size, 8 feet-3/4 size and 1 inch size) Support should be with metal EMT conduit straps or two-point attachment plastic clips suitable for the size of the tubing.
5. If a manifold is used, it shall be rigidly mounted to the I-beam flange. This applies to parallel system layouts.
6. The gas piping shall be bonded to the frame of the home by the use of:
  - a. Solderless type grounding terminal with a star washer bolted to the chassis;
  - b. Grounding clamp attached to a gas piping fitting. (For attachment of clamp to **TracPipe**<sup>®</sup> fitting, refer to Section 4.10 – Electrical Bonding/Grounding. Do not clamp to the stainless steel portion under any circumstances.); and
  - c. Bonding electrode conductor sizing shall be in accordance with the Canadian Electrical Code (C22.1) 10-406(4).

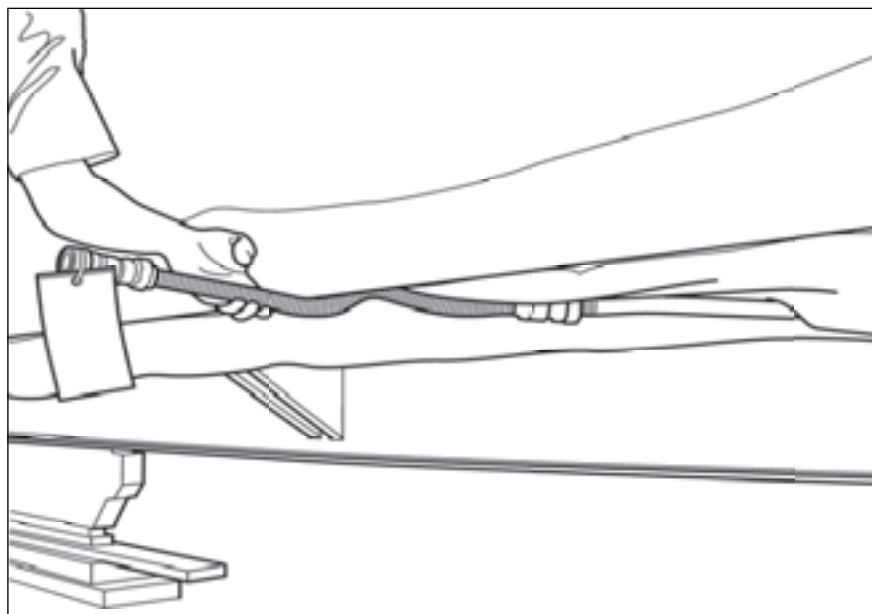

7. Concealed tubing: CSST shall not be run inside walls, partitions or roofs. Where tubing passes through walls, floors, partitions, roofs, or similar installations, such tubing shall be protected by the use of weather resistant grommets that shall snugly fit both the tubing and the hole through which the tubing passes. DO NOT remove the yellow polyethylene jacket in any penetrations.
8. All CSST tubing joints shall have any exposed sections of stainless steel piping wrapped with silicone self-bonding tape. The under-floor portion of the manufactured home is considered an outdoor location. Proper support (per item B. 4. previous page) is required under the floor.
9. Retrofit of appliances:
  - a. The gas supply connection shall be rigidly anchored to a structural member within 6 inches of supply connection.
  - b. CSST shall be supported and protected per manufacturer's instructions. (See items 4 and 7 above.)
  - c. Pressure test gas piping per item C on following page before operating appliance.

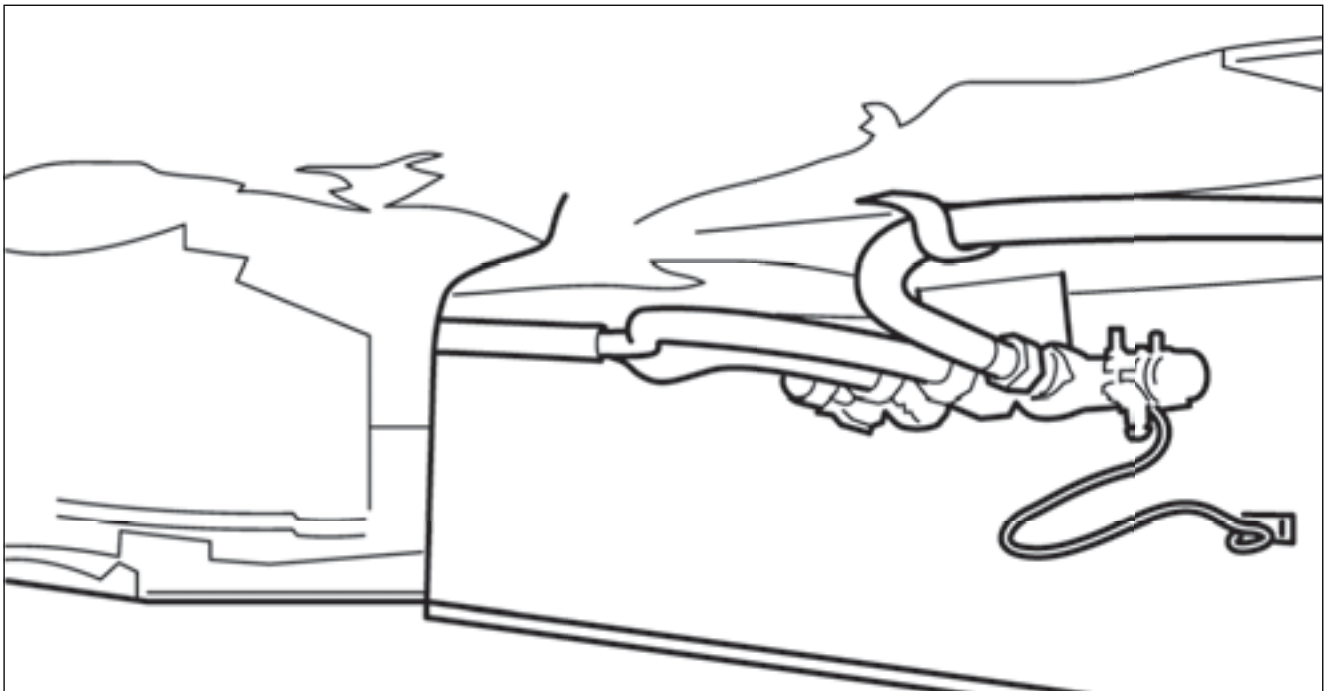

### C. INSPECTION AND TEST REQUIREMENTS

1. Pressure test in accordance with CAN-CSA-B149.1, Section 6.22, "Testing of Piping, Tubing, Hose and Fittings" before appliances are connected.



## APPENDIX C

### SECTION C1.1 - AUTOTRIP® LOW PRESSURE EXCESS FLOW VALVES FOR NATURAL GAS AND PROPANE SERVICE

An excess flow valve (EFV) is a protective device to help control the discharge of fuel gas in the event of a complete breakage of pipe lines or flex connector rupture. Excess flow valves have been of help in limiting gas loss in many incidents involving breakage of piping; thus they do provide a useful safety function in gas systems. This section explains what protection excess flow valves can offer, points out conditions which can interfere with that protection, and offers suggestions for effective excess flow valve installation.

1. There are two types of **AutoTrip** EFVs: LFD Series Line/Meter excess flow valves and AFD Series Appliance Connector excess flow valves.



LFD Series

A. **AutoTrip** LFD Line/Meter Excess Flow Valves (EFVs) protect against potential damage due to the release of fuel gas as a result of residential and commercial gas line breaks. **AUTOTRIP** excess flow valves work in conjunction with all approved gas piping materials (**TracPipe**®, other brands of CSST, steel pipe, and copper tube) at the gas meter, second stage regulator, the appliance branch line or manifold connection.

B. **AutoTrip** AFD Appliance Connector Excess Flow Valves protect against potential damage due to the release of fuel gas when a flexible gas appliance connector line breaks.



AFD Series

**AUTOTRIP** Appliance Connector EFVs act to restrict the flow of gas should the downstream appliance connector suffer a complete break or pull-out. The inlet side of the **AUTOTRIP** Appliance Connector excess flow valve adapts to all approved gas piping materials (**TracPipe**®, other brands of CSST, steel pipe, and copper tube) with an NPT connection. The Outlet side comes equipped with an SAE flare for connection to standard appliance connectors.

#### 2. Quality Assurance

- **AutoTrip** valves are Design-Certified by CSA International and manufactured and 100% factory tested in accordance with the IAS U.S. Requirements 3-92 for Excess Flow Valves.
- Listed by IAPMO File 5031-International Association of Plumbing and Mechanical Officials.
- Listed by CA-DSA-California Division of State Architect.

#### 3. IMPORTANT NOTES and LIMITATIONS Regarding the Use of Excess Flow Valves

Installation of the **AutoTrip** excess flow valve must only be performed by a qualified plumber or gas fitter who meets state and/or local requirements to perform work on fuel gas piping systems. The **AutoTrip** valve must be installed in compliance with local codes or, in the absence of local codes, with the National Fuel Gas Code ANSI Z223.1/NFPA 54, The International Fuel Gas Code, or The Uniform Plumbing Code.

## IMPORTANT

1. **DANGER:** Read all installation instructions and limitations before installing.
2. Size the excess flow valve to match the gas demand for appliances installed. See sizing instructions below. DO NOT OVERSIZE the valve for anticipated appliance additions.
3. Prior to installing, TURN OFF gas supply using an upstream shut-off valve.
4. Install the excess flow valve with the proper flow direction as marked on the label and in the correct position (vertical up only for LFD models) and (multipoise [any position] for AFD models) as specified in these instructions.
5. After installation is complete, pressurize system by opening gas supply shut off valve VERY SLOWLY to initiate gas service.
6. Check all connections with a non-corrosive leak detector solution to assure connections are leak tight. (Available: **TracPipe** Leak Check Solution P/N FGP-LCS).

### 4. LIMITATIONS OF AUTOTRIP EXCESS FLOW VALVES FOR NATURAL GAS AND PROPANE SYSTEMS

**AUTOTRIP** excess flow valves are designed to protect against complete breakage of gas lines DOWNSTREAM of the location of which the **AUTOTRIP** excess flow valve is installed. **AUTOTRIP** excess flow valves installed at the Meter are designed only to protect the main trunk line piping of like size of which it was installed. These devices may not protect against gas piping breaks at a given length downstream from the EFV or after a reduction in pipe size. Additional factors that may affect the proper function of an EFV:

1. The system was not sized properly to allow the EFV to close upon complete breakage of a gas line.
2. The system was not sized properly with the EFV to allow proper operation of all appliances.
3. The supply pressure is not great enough to provide the required capacity.
4. Restrictions exist in the gas piping system that prevent proper operation of the EFV such as, but not limited to, reductions in pipe size, incomplete or partial breaks of gas lines, partially open or smaller than full-bore valves or components in the gas piping system, any additional restrictions that would prevent the required capacity of gas to escape from the system that would close the valve.
5. Foreign matter, such as pipe thread sealant, is lodged in valve, preventing closure.
6. The excess flow valve has been damaged by fire or improper installation and is no longer in operating condition.

**NOTE:** If the valve is not in operating condition, IT MUST BE REPLACED.

## **SECTION C1.2 - AUTOTRIP LFD SERIES EXCESS FLOW VALVES FOR METER AND BRANCH LINE/MANIFOLD APPLICATIONS**

### LFD SERIES PRODUCT SPECIFICATIONS

Material Specification:

Body	Brass Nickel Plated
Seat & Retainer	Polyamide
Valve Float / Ball	POM or PTFE
<u>Operating Temperature:</u>	-20°F to 150°F
<u>Operating Pressure:</u>	0.18 PSI (5 inch wc) to 2 PSI
<u>Maximum Bypass Flow:</u>	10 CFH (Air equivalent)



**LFD Series**

*For additional product information including Model Numbers, inlet/outlet thread connections, Maximum load capacity and flow rates, & application please reference Table: C.1.*

## C1.2.1 - APPLICATION AND SELECTION OF AUTOTRIP LFD SERIES EXCESS FLOW VALVES

- Application. Determine the Type of EFV based on the application (See Figure: C-1):
  - Meter
  - Branch Line
- EFV Model Selection. From Table: C-1, select the appropriate **AUTOTRIP** LFD Series EFV(s) based on the TOTAL BTU/hr load capacity of the appliance(s) it serves. For a Meter application, this is the TOTAL BTU/hr load capacity of ALL the appliance(s) served by the gas meter. For a Branch Line application, this is the BTU/hr load capacity of the appliance(s) on the branch for

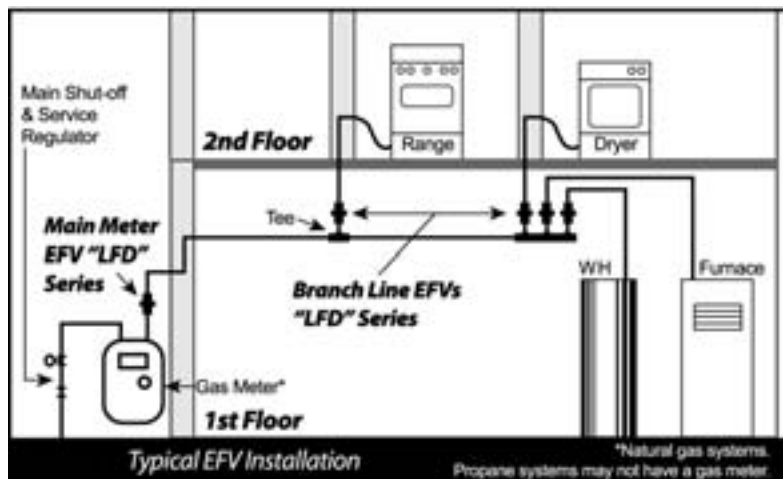

Figure: C-1

which the **AUTOTRIP** EFV is installed. The TOTAL BTU/hr load capacity of the appliance(s) should be equal to or less than the Maximum Load Capacity (BTU/hr) value of the **AUTOTRIP** LFD Series EFV selected from Table: C-1.

Table: C-1  
**AUTOTRIP** LFD Series Excess Flow Valves Application Data

EFV Type - Application	OmegaFlex AUTOTRIP P/N	Mounting Position	Inlet Thread Connection(s)	Outlet Thread Connection(s)	Maximum Load Capacity (BTU/hr)	Nominal Closure Flow Rate (SCFH)
Appliance Branch Line	FGP-LFD-70	Vertical Up ONLY	3/4" M-NPT & 1/2" F-NPT	3/4" M-NPT & 1/2" F-NPT	70,000	97
Appliance Branch Line	FGP-LFD-125	Vertical Up ONLY	3/4" M-NPT & 1/2" F-NPT	3/4" M-NPT & 1/2" F-NPT	125,000	147
Meter / Branch Line	FGP-LFD-275A	Vertical Up ONLY	3/4" M-NPT & 1/2" F-NPT	3/4" M-NPT & 1/2" F-NPT	275,000	335
Meter / Branch Line	FGP-LFD-275B	Vertical Up ONLY	1" M-NPT & 3/4" F-NPT	1" M-NPT & 3/4" F-NPT	275,000	335
Meter / Branch Line	FGP-LFD-375	Vertical Up ONLY	1" M-NPT & 3/4" F-NPT	1" M-NPT & 3/4" F-NPT	375,000	460
Meter / Branch Line	FGP-LFD-500	Vertical Up ONLY	1 1/4" M-NPT & 1" F-NPT	1 1/4" M-NPT & 1" F-NPT	500,000	685

### Notes:

- Flow Rates given for 0.60 Specific Gravity Natural Gas with an Avg. Heating Value of 1000 BTU / cubic foot.
- To convert Maximum Load Capacity value to BTU/hr Propane (1.52 Specific Gravity, 2520 BTU / cubic foot), multiply Natural Gas Value by 1.583.
- To convert SCFH Nominal Closure Flow Rate to SCFH Propane, multiply Natural gas Value above by 0.628
- Abbreviations: w.c. = inches water column  
SFCH = Standard Cubic Feet per Hour

## C1.2.2 - GAS PIPING SYSTEM SIZING WITH LFD SERIES EXCESS FLOW VALVES

**AUTOTRIP** LFD Series excess flow valves must be sized properly for the gas piping system in which they are installed. When installing **AUTOTRIP** excess flow valves within a fuel gas piping system, the user must assure that:

1. The **AUTOTRIP** LFD Series EFV will close upon a complete breakage or rupture of gas piping at an expected length downstream of the EFV. It is recommended that the installer conduct tests on the gas piping system to ensure the EFV(s) will function as intended. **Note:** Tests should be performed in accordance with all applicable local and national codes.
2. The addition of the **AUTOTRIP** LFD Series EFV will allow all appliances to which the EFV serves to operate properly without the undue loss of pressure. It is recommended that the installer run all appliances with the EFV(s) installed to assure proper operation.

## C1.2.3 - METHODS OF SIZING

### STANDARD SIZING METHOD -

When sizing a gas piping system including **AutoTrip** LFD Series EFVs, size the gas piping system using the following Tables: (N-1AT, N-3AT, N-5AT, SP-1AT, P-1AT) using standard methods of gas pipe sizing – Branch Length or Longest Run Method.

### ALTERNATE SIZING METHOD –

If using an Engineered Method, i.e. “Sum of Pressures Method” of gas pipe sizing, use the pressure drop values in Figure: C-3 in your gas piping calculations.

## C1.2.4 - SIZING INSTRUCTIONS FOR AUTOTRIP LFD SERIES EFVS USED WITH TRACPIPE CSST SYSTEMS

- A. Meter Applications (LFD Series LFD-275A, LFD-275B, LFD-375, LFD-500).
  1. Choose the appropriate **AutoTrip** LFD Series Meter EFV using Table: C-1 based on the total capacity of the gas piping system served by that meter.
  2. Using the appropriate **AutoTrip** Capacity Chart “Table: N-1AT **AutoTrip** Low Pressure” or “Table: N-5AT **AutoTrip** (2-PSI system)” based upon system pressure; determine the size of CSST based on the **AutoTrip** EFV selected in Step 1 and the appropriate sizing length. This size of CSST is designed to allow the **AutoTrip** EFV to act as a safety shut-off valve in the event of a complete breakage of the main trunk line piping.
- B Branch Line / Manifold Applications (LFD Series LFD-70, LFD-125, LFD-275A, LFD-275B, LFD-375, and LFD-500).
  1. Elevated Pressure 2 PSI system (Manifold with parallel arrangement).
    - a. Choose the appropriate size **AutoTrip** LFD Series Appliance Branch Line EFV using Table: 3-1 based on the capacity for each manifold outlet. Select an EFV with sufficient capacity to supply the appliance(s) connected to the outlet.
    - b. Using **AutoTrip** Capacity Chart “Table: N-3AT **AutoTrip** Dual Pressure System” determine size of **TracPipe** CSST based on the **AutoTrip** EFV selected in Step a and the appropriate sizing length from the manifold to the appliance(s). This size of CSST is designed to allow the **AutoTrip** EFV to act as a safety shut-off valve in the event of the complete breakage of the downstream branch pipe line or flex connector rupture.

2. Series System Low Pressure.
  - a. When there is no manifold, the EFV should be located at the tee or fitting where the appliance drop attaches to the trunk line. If this is a concealed location, follow local codes.
  - b. Choose the appropriate size **AutoTrip** LFD Series Appliance Branch Line EFV using Table: C-1 based on the capacity for that branch line. Select an EFV with sufficient capacity to supply the appliance(s) connected to that drop.
  - c. Using **AutoTrip** Capacity Chart "Table: N-1AT **AutoTrip** Low Pressure" determine size of **TracPipe** CSST based on the **AutoTrip** EFV selected in Step b and the appropriate sizing length from the appliance back to the meter. This size of CSST is designed to allow the **AutoTrip** EFV to act as a safety shut-off valve in the event of a complete breakage of the downstream branch pipe line or flex connector rupture.

## **C1.2.5 - SIZING INSTRUCTIONS FOR AUTOTRIP LFD SERIES EFVS USED WITH LOW PRESSURE STEEL PIPE SYSTEMS**

1. Choose the **AutoTrip** LFD Series EFV (Appliance branch line or Meter) using Table: C-1 which will supply the necessary capacity of the meter or appliance(s) it serves.
2. Using **AutoTrip** Capacity Chart "Table: SP-1AT **AutoTrip** Steel Pipe Low Pressure" determine the size of steel pipe based on the **AutoTrip** EFV selected in Step: 1 and the appropriate sizing length. This size of steel pipe is designed to allow the **AutoTrip** EFV to act as a safety shut-off valve in the event of a complete breakage of the main trunk line piping (Meter EFV) or of the downstream branch pipe line or flex connector rupture (Appliance Branch Line EFV).

## **C1.2.6 - LFD INSTALLATION INSTRUCTIONS**

- A. Installation of **AUTOTRIP** LFD Series Meter Application excess flow valves downstream of the Gas Meter Outlet

The **AUTOTRIP** device can be installed downstream of the gas company meter and bypass tee outlet using standard pipe fittings and procedures. **AUTOTRIP** Meter Valves-LFD models must be installed within 5 degrees of the vertical position with the flow arrow pointing upward in the direction of flow. **Note:** EFVs installed at the Meter are designed only to protect the main trunk line of like pipe size downstream of the EFV.

- B. Installation of **AUTOTRIP** LFD Series Branch Line excess flow valves at the Tee or Manifold connection of a Branch Line to an Appliance.

**AUTOTRIP** Branch Line excess flow valves should be connected directly to the manifold outlet at the point between the manifold and the gas appliance lines. If there is no manifold, the valves could be located at the tee or fitting where the appliance drop attaches to the trunk line. **AUTOTRIP** Branch Line excess flow valves must be installed in the vertical position (within 5 degrees) with the flow arrow pointing upward in the direction of flow.

- C. **Step-by-Step Installation Instructions**
  1. Prior to installing the **AUTOTRIP** excess flow valve (EFV), turn gas supply off upstream of the EFV using appropriate shut-off valve. For a Meter EFV installation, this will be the main gas company shut-off valve.
  2. Install **AUTOTRIP** EFV into piping system at desired location using appropriate pipe fittings and tools. When using a thread sealant on pipe threads, do not allow the sealant, Teflon tape or any debris to enter the valve. Foreign matter can lodge in the valve and prevent proper operation.



3. After **AUTOTRIP** EFV is installed, insure all connections in the gas piping system are gas tight.
4. Re-open upstream shut-off valve SLOWLY to re-pressurize the system. **NOTE:** If upstream shut-off valve is opened too quickly and an excess flow condition is created due to a pressure surge the **AUTOTRIP** EFV may trip (close). If this occurs, reset the valve using the Resetting an **AUTOTRIP** EFV instructions below.

5. **Resetting an AUTOTRIP EFV that has “tripped” (closed).** Turn gas supply off upstream of the EFV using appropriate shut-off valve. For a Meter EFV installation, this will be the main gas company shut-off valve. Repair all damaged piping as required. Reset the **AutoTrip** EFV by closing and sealing off all downstream connections. Once the pressure in the upstream and downstream piping

is equalized, the EFV will reset. This is evident by a “soft click” that can be heard from the **AutoTrip** EFV. Typical time to reset is 1-2 minutes or of greater duration for larger diameter and/or longer lengths of downstream piping. Repeat Step 4. above to re-pressurize the system.

**NOTE:** If there are any open connections (assure all appliance valves are shut) or leaks downstream of the **AUTOTRIP** EFV, the EFV will not reset!

**CAUTION:** Installer must assure at all times that any gas that may have escaped from the gas piping system as a result of a pipe break, valve testing, leakage, etc. is completely dissipated prior to opening appliance shut-offs and firing of appliances. Assure that there is no electrical or motorized equipment in use during this process.

## SECTION C1.3 - AUTOTRIP AFD SERIES EXCESS FLOW VALVES FOR APPLIANCE CONNECTOR INLET APPLICATIONS

### AFD SERIES PRODUCT SPECIFICATIONS

Material Specification:

Body	Brass Nickel Plated
Seat	Polyamide
Valve Float	Polyamide
Spring	Stainless Steel
<u>Operating Temperature:</u>	32°F to 150°F
<u>Operating Pressure:</u>	0.18 PSI (5 inch wc) to 1/2 PSI
<u>Maximum Bypass Flow:</u>	10 CFH (Air equivalent)



*For additional product information including Model Numbers, inlet/outlet thread connections, Maximum load capacity and flow rates, & application please reference Table: C-2.*

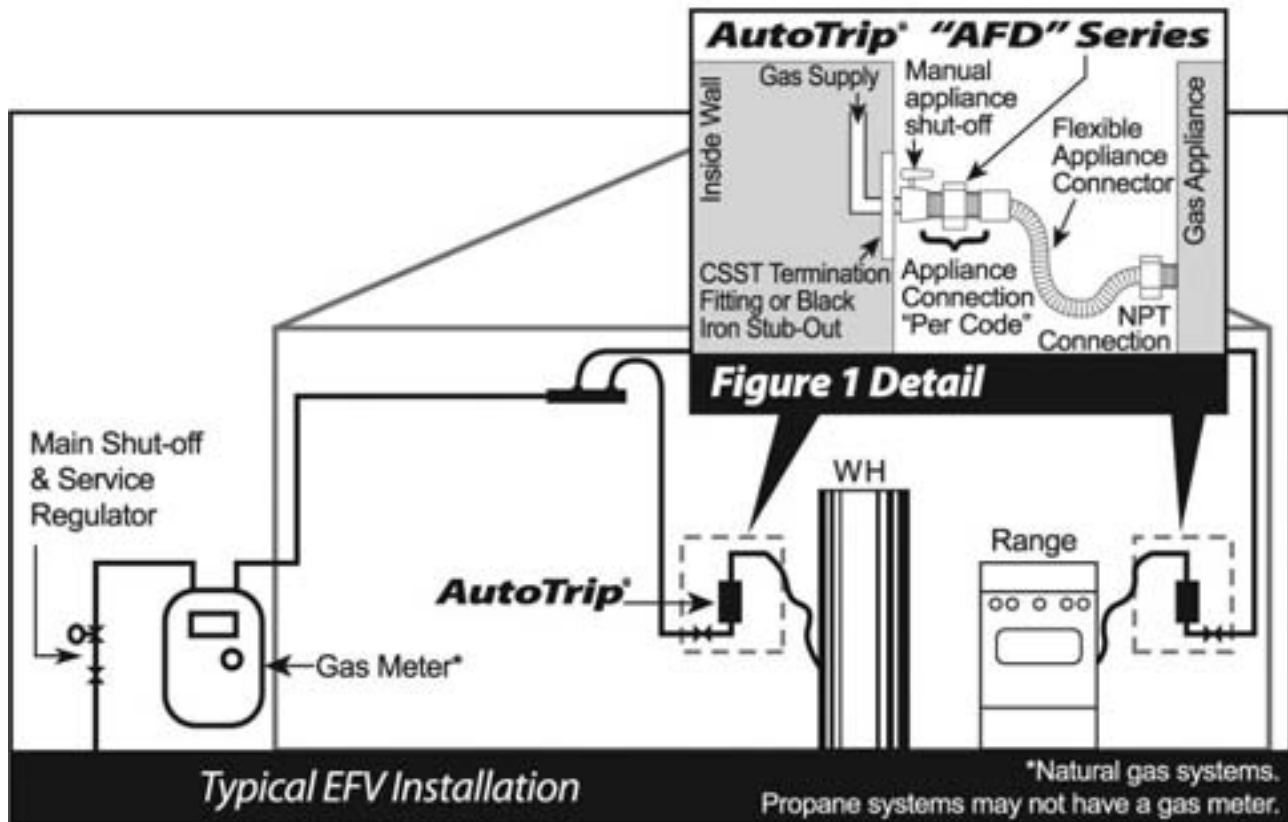

Figure: C-2

### C1.3.1 - APPLICATION AND SELECTION OF AUTOTRIP AFD SERIES EXCESS FLOW VALVES

1. Application. Determine the Type of EFV based on the application – for the AFD Series the application will be to install the EFV at the inlet to a flexible appliance connector (See Figure: C-2).
2. AFD Series EFV Model Selection. From Table C.2, select the appropriate **AUTOTRIP** AFD EFV based on:
  - A. The BTU/hr load capacity of the appliance it serves. (**Note:** **AUTOTRIP** Appliance Connector EFVs will serve only the appliance for which the flexible appliance connector is installed to). The TOTAL BTU/hr load capacity of the appliance should be equal to or less than the Maximum Load Capacity (BTU/hr) value of the **AUTOTRIP** AFD EFV in Table: C-2.

B. Inlet side NPT and Outlet side SAE Flare connections, Nominal ID of the appliance connector being used.

- 3 Gas Piping System Sizing with an **AUTOTRIP** AFD Series excess flow valve(s).

**AUTOTRIP** excess flow valves must be sized properly for the gas piping system in which they are installed. When installing **AUTOTRIP** excess flow valves within a fuel gas piping system, the user must assure that:

- A. The **AUTOTRIP** excess flow valve will close upon a complete breakage or rupture of the gas appliance connector piping downstream of the EFV. It is recommended that the installer conduct tests on the gas piping system to ensure the EFV(s) will function as intended. **Note:** Tests should be performed in accordance with all applicable local and national codes.

- B. The addition of the EFV will allow the appliance to which the EFV serves to operate properly without the undue loss of pressure. It is recommended that the installer run all appliances with the EFV(s) installed to assure proper operation.

Based on the upstream gas piping system sizing and downstream appliance connector sizing, the user must assure that the addition of the AFD Series EFV will not reduce the inlet pressure to the appliance below the minimum required for proper operation.

**NOTE:** AFD Series EFVs will add a Nominal 0.5 inch wc pressure drop when operating at the Maximum Load Capacity (BTU/hr) of the EFV.

### C1.3.2 - INSTALLATION INSTRUCTIONS

- A. Installation of **AUTOTRIP** Appliance Connector excess flow valves to the Flare connection of a Flexible Appliance Connector.

**AUTOTRIP** Appliance Connector excess flow valves should be connected to the SAE Flare connection on the inlet side of an approved flexible appliance connector. **AUTOTRIP** Appliance Connector excess flow valves are designed for multipoise installation so they may be installed in the vertical, horizontal, or any angle from the horizontal, positions. **NOTE:** Appliance Connector **AUTOTRIP** excess flow valves are designed to protect against a complete breakage or pull-out of the flexible appliance connector only. This device will not protect gas piping upstream of the device.

- B. Step-by-Step Installation Instructions:

1. Prior to installing the **AUTOTRIP** excess flow valve (EFV), turn gas supply off upstream of the EFV using appropriate shut-off valve. If the appliance shut-off valve is installed upstream of the appliance connector, this valve may be used as the shut-off.

**TABLE: C-2**  
**AUTOTRIP “AFD” Series Appliance Connector Inlet Excess Flow Valves Application Data**

EFV Type - Application	OmegaFlex AUTOTRIP P/N	Fits Nominal Appliance Connector ID Size	Mounting Position	Inlet Thread Connection(s)	Outlet Thread Connection(s)	Maximum Load Capacity (BTU/hr)	Nominal Closure Flow Rate (SCFH)
Appliance connector	FGP-AFD-80	1/4"	Multipoise	1/2" M-NPT & 3/8" F-NPT	3/8" SAE Flare	80,000	110
Appliance connector	FGP-AFD-100A	3/8"	Multipoise	1/2" M-NPT & 3/8" F-NPT	1/2" SAE Flare	100,000	175
Appliance connector	FGP-AFD-130A	1/2"	Multipoise	1/2" M-NPT & 3/8" F-NPT	5/8" SAE Flare	130,000	200
Appliance connector	FGP-AFD-130B	1/2"	Multipoise	3/4" M-NPT & 1/2" F-NPT	5/8" SAE Flare	130,000	200

**Notes:**

- 1) Flow Rates given for 0.60 Specific Gravity Natural Gas with an Avg. Heating Value of 1000 BTU / cubic foot.
- 2) To convert Maximum Load Capacity value to BTU/hr Propane (1.52 Specific Gravity, 2520 BTU / cubic foot), multiply Natural Gas Value by 1.583.
- 3) To convert SCFH Nominal Closure Flow Rate to SCFH Propane, multiply Natural gas Value above by 0.628.
- 4) Abbreviations: "w.c. = inches water column.  
SCFH = Standard Cubic Feet per Hour.

2. Install **AUTOTRIP** EFV at the inlet to the flexible appliance connector using appropriate pipe fittings and tools. When using a thread sealant on pipe threads, do not allow the sealant, Teflon tape or any debris to enter the valve. Foreign matter can lodge in the valve and prevent proper operation.
3. After **AUTOTRIP** EFV is installed, insure all connections in the gas piping system are gas tight.
4. Re-open upstream shut-off valve SLOWLY to re-pressurize the system. **NOTE:** If upstream shut-off valve is opened too quickly and an excess flow condition is created due to a pressure surge the **AUTOTRIP** EFV may trip (close). If this occurs, reset the valve using the Resetting an **AUTOTRIP** EFV instructions below.
5. Resetting an **AUTOTRIP** EFV that has “tripped” (closed). Repair all damaged piping as required. Reset the **AUTOTRIP** EFV by closing and sealing off all downstream connections. Once the pressure in the downstream piping is equalized, valve will reset. This is evident by a “soft click” that can be heard from the **AUTOTRIP** EFV. Typical time to reset is 15-30 seconds or of greater duration for larger diameter or longer length appliance connectors.

**NOTE:** If there are any open connections (assure all appliance valves are shut) or leaks downstream of the **AUTOTRIP** EFV, valve will not reset!

**NOTE:** Resetting **AUTOTRIP** appliance connector EFVs with appliance shut-off valve installed UPSTREAM of the EFV – These valves may be reset by closing and SLOWLY re-opening the upstream appliance shut-off valve without “tripping” the EFV.

**CAUTION:** Installer must assure at all times that any gas that may have escaped from the gas piping system as a result of a pipe break, valve testing, leakage, etc. is completely dissipated prior to opening appliance shut-offs and firing of appliances. Assure that there is no electrical or motorized equipment in use during this process.

## **SECTION C1.4 - GASBREAKER® EXCESS FLOW VALVES**

GasBreaker® excess flow valves (EFV) protect against residential and commercial gas line breaks. GasBreakers work in conjunction with **TracPipe**, other brands of CSST or rigid gas piping at the gas meter, second stage regulator, the appliance branch line or manifold connection. GasBreaker EFVs are available in several different sizes and load capacity ratings.

1. The GasBreaker EFV can be installed downstream of the gas company meter and bypass tee outlet using standard pipe fittings and procedures. GasBreaker EFVs must be installed within 5 degrees of the vertical position with the flow arrow pointing upward in the direction of flow.
2. Use Table: C-4 for GasBreaker EFV capacity information and to determine the equivalent **AutoTrip** LFD excess flow valve. For sizing of the **TracPipe** CSST system with GasBreaker EFV's utilize the equivalent **AutoTrip** capacity chart data.

**TABLE N-1AT AUTOTRIP-TRACPIPE (Low Pressure System)**  
**Determine TracPipe CSST size based upon the AutoTrip “LFD” Series EFV Chosen and Length of CSST Run**  
**Standard Low Pressure 0.5 PSI or less (7 inch w.c.)-Piping Pressure Drop 0.5 inch w.c.**

**Distance Range – Length in Feet**

AutoTrip P/N	Max. Capacity BTU	0-10 Feet	<15	<20	<25	<40	<50	<60	<90	<100	<150	<200	<250	<300
Appliance Branch Line Series														
FGP-LFD-70	70,000	1/2"	1/2"	3/4"	3/4"	3/4"	3/4"	3/4"	3/4"	1"	1"	1"	1"	1-1/4"
FGP-LFD-125	125,000	3/4"	3/4"	3/4"	3/4"	1"	1"	1"	1"	1-1/4"	1-1/4"	1-1/2"	1-1/2"	1-1/2"
Meter / Line Series														
FGP-LFD-275A or -275B	275,000	1"	1"	1-1/4"	1-1/4"	1-1/4"	1-1/2"	1-1/2"	1-1/2"	1-1/2"	1-1/2"	1-1/2"	1-1/2"	2"
FGP-LFD-375	375,000	1"	1-1/4"	1-1/4"	1-1/2"	1-1/2"	1-1/2"	1-1/2"	1-1/2"	1-1/2"	2"	2"	2"	2"
FGP-LFD-500	500,000	1-1/4"	1-1/2"	1-1/2"	1-1/2"	1-1/2"	1-1/2"	1-1/2"	2"	2"	2"	2"	2"	2"

**NOTE:** If you are installing a brand of CSST other than **TracPipe**, size each run to supply the Max Capacity of the **AutoTrip** device instead of the capacity of appliances on that run.

**TABLE N-3AT AUTOTRIP-TRACPIPE (Dual Pressure System-8 inch w.c. - Regulator outlet @ manifold)**  
**Determine TracPipe CSST size based upon the AutoTrip “LFD” Series EFV Chosen and Length of CSST Run**  
**Regulator Outlet for 2-PSI Distance Range – Length in Feet**

GasBreaker P/N	Max. Capacity BTU	0-10 Feet	<15	<20	<25	<30	<40	<50	<60	<80	<90	<100	<150	<200	<250	<300
Appliance Branch Line Series																
FGP-LFD-70	70,000	3/8"	3/8"	1/2"	1/2"	1/2"	1/2"	1/2"	1/2"	1/2"	1/2"	1/2"	3/4"	3/4"	3/4"	3/4"
FGP-LFD-125	125,000	1/2"	1/2"	1/2"	1/2"	1/2"	3/4"	3/4"	3/4"	3/4"	3/4"	3/4"	3/4"	1"	1"	1"
Meter / Line Series																
FGP-LFD-275A or -275B	275,000	3/4"	3/4"	3/4"	3/4"	1"	1"	1"	1"	1"	1"	1"	1-1/4"	1-1/4"	1-1/4"	1-1/2"
FGP-LFD-375	375,000	3/4"	3/4"	1"	1"	1"	1"	1"	1"	1-1/4"	1-1/4"	1-1/4"	1-1/2"	1-1/2"	1-1/2"	1-1/2"
FGP-LFD-500	500,000	1"	1"	1"	1"	1"	1-1/4"	1-1/4"	1-1/4"	1-1/4"	1-1/2"	1-1/2"	1-1/2"	1-1/2"	1-1/2"	1-1/2"

**NOTE:** If you are installing a brand of CSST other than **TracPipe**, size each run to supply the Max Capacity of the **AutoTrip** device instead of the capacity of appliances on that run.

**TABLE N-5AT AUTOTRIP -TRACPIPE (2-PSI system)**  
**Determine TracPipe CSST size based upon the AutoTrip "LFD" Series EFV Chosen and Length of CSST Run**  
**Meter Outlet for 2-PSI system (Elevated Pressure) – Piping Pressure Drop 1-PSI**

**Distance Range – Length in Feet**

GasBreaker P/N	Max. Capacity BTU	0-10 Feet	<25	<30	<40	<50	<75	<80	<100	<150	<200	<250	<300	<400	<500
Meter / Line Series															
FGP-LFD-275A or -275B	275,000	3/8"	1/2"	1/2"	1/2"	1/2"	3/4"	3/4"	3/4"	3/4"	3/4"	3/4"	3/4"	1"	1"
FGP-LFD-375	375,000	1/2"	1/2"	1/2"	3/4"	3/4"	3/4"	3/4"	3/4"	3/4"	1"	1"	1"	1"	1"
FGP-LFD-500	500,000	1/2"	3/4"	3/4"	3/4"	3/4"	3/4"	3/4"	1"	1"	1"	1"	1"	1-1/4"	1-1/4"

**NOTE:** if you are installing a brand of CSST other than *TracPipe*, size each run to supply the Max Capacity of the *AutoTrip* device instead of the capacity of appliances on that run.

**TABLE SP-1AT AUTOTRIP - STEEL PIPE LOW PRESSURE**  
**Determine pipe size based upon the AutoTrip "LFD" Series EFV Chosen and Length of Run**  
**Standard Low Pressure 0.5 PSI or less (7 inch w.c.)—Piping Pressure Drop 0.5 inch w.c.**

**Distance Range – Length in Feet**

GasBreaker P/N	Max. Capacity BTU	0-10 Feet	<20	<30	<40	<50	<60	<70	<90	<100	<125	<150	<200	<250	<300
Appliance Branch Line Series															
FGP-LFD-70	70,000	1/2"Pipe	1/2"	1/2"	1/2"	3/4"	3/4"	3/4"	3/4"	3/4"	3/4"	3/4"	3/4"	1"	1"
FGP-LFD-125	125,000	1/2"Pipe	3/4"	3/4"	3/4"	3/4"	3/4"	3/4"	1"	1"	1"	1"	1"	1-1/4"	1-1/4"
Meter / Line Series															
FGP-LFD-275A or -275B	275,000	3/4"Pipe	1"	1"	1"	1"	1-1/4"	1-1/4"	1-1/4"	1-1/4"	1-1/4"	1-1/4"	1-1/4"	1-1/2"	1-1/2"
FGP-LFD-375	375,000	1"Pipe	1"	1"	1-1/4"	1-1/4"	1-1/4"	1-1/4"	1-1/4"	1-1/4"	1-1/2"	1-1/2"	1-1/2"	1-1/2"	2"
FGP-LFD-500	500,000	1"Pipe	1-1/4"	1-1/4"	1-1/4"	1-1/4"	1-1/4"	1-1/2"	1-1/2"	1-1/2"	1-1/2"	1-1/2"	2"	2"	2"

**TABLE 3-3**  
**PROPANE—AutoTrip “LFD” Series Excess Flow Valves**

AutoTrip Flow Rates in 1.52 S.G. / 2520 BTU/cu.feet PROPANE						
Device	Btu/hr			SCFH		
	Typ. Load	Max Load	Nom. Closing	Typ. Load	Max Load	Nom. Closing
Appliance Branch Line Series						
FGP-LFD-70	110,779	110,779	158,256	44	44	63
FGP-LFD-125	189,907	197,820	276,948	75	79	110
Meter / Line Series						
FGP-LFD-275A	197,820	435,204	561,809	79	173	223
FGP-LFD-275B	276,948	435,204	561,809	110	173	223
FGP-LFD-375	284,861	593,460	751,716	113	236	298
FGP-LFD-500	284,861	791,280	1,084,054	113	314	430

**TABLE P-1AT AUTOTRIP (Propane Low Pressure System 11 inch w.c.)-TRACPIPE**  
**Determine TracPipe CSST size based upon the AutoTrip “LFD” Series EFV Chosen and Length of CSST Run**  
**Standard Propane Low Pressure (11 inch w.c.)—Piping Pressure Drop 0.5 inch w.c.**

**Distance Range – Length in Feet**

AutoTrip P/N	Max. Capacity BTU	0-10 Feet	<15	<20	<25	<40	<50	<60	<90	<100	<150	<200	<250	<300
Appliance Branch Line Series														
FGP-LFD-70	110,779	1/2"	1/2"	3/4"	3/4"	3/4"	3/4"	3/4"	1"	1"	1"	1"	1"	1-1/4"
FGP-LFD-125	197,820	3/4"	3/4"	3/4"	3/4"	1"	1"	1"	1"	1-1/4"	1-1/4"	1-1/2"	1-1/2"	1-1/2"
Meter / Line Series														
FGP-LFD-275A or -275B	435,204	1"	1"	1-1/4"	1-1/4"	1-1/4"	1-1/2"	1-1/2"	1-1/2"	1-1/2"	1-1/2"	1-1/2"	2"	2"
FGP-LFD-375	593,460	1"	1-1/4"	1-1/4"	1-1/4"	1-1/2"	1-1/2"	1-1/2"	1-1/2"	1-1/2"	2"	2"	2"	2"
FGP-LFD-500	791,280	1-1/4"	1-1/2"	1-1/2"	1-1/2"	1-1/2"	1-1/2"	1-1/2"	2"	2"	2"	2"	2"	2"

**NOTE:** If you are installing a brand of CSST other than **TracPipe**, size each run to supply the Max Capacity of the **AutoTrip** device instead of the capacity of appliances on that run.

**TABLE C-4**  
**AUTOTRIP - GasBreaker Equivalency Chart**

EFV Type Application	Maximum Load Capacity(Btu/hr)	Auto Trip P/N	Auto Trip Inlet and Outlet Thread Connection(s)	Equivalent GasBreaker P/N	GasBreaker Inlet and Outlet Thread Connection
Appliance Branch Line	70,000	FGP-LFD-70	3/4" M-NPT & 1/2" F-NPT	FGP-GB090-075	3/4" M-NPT
Appliance Branch Line	125,000	FGP-LFD-125	3/4" M-NPT & 1/2" F-NPT	FGP-GB150-075	3/4" M-NPT
Meter / Branch Line	275,000	FGP-LFD-275A	3/4" M-NPT & 1/2" F-NPT	FGP-GB300-075	3/4" M-NPT
Meter / Branch Line	275,000	FGP-LFD-275B	1" M-NPT & 3/4" F-NPT	FGP-GB300-100	1" M-NPT
Meter / Branch Line	375,000	FGP-LFD-375	1" M-NPT & 3/4" F-NPT	FGP-GB400-100	1" M-NPT
Meter / Branch Line	500,000	FGP-LFD-500	1-1/4" M-NPT & 1" F-NPT	FGP-GB600-100	1" M-NPT

**NOTE:** For additional information regarding the *Auto Trip* or GasBreaker excess flow valves, please contact **OmegaFlex** at 800-671-8622.



**FIGURE C-3**  
**Pressure Drop across Auto Trip "LFD" Series EFV at given Flow Rates**

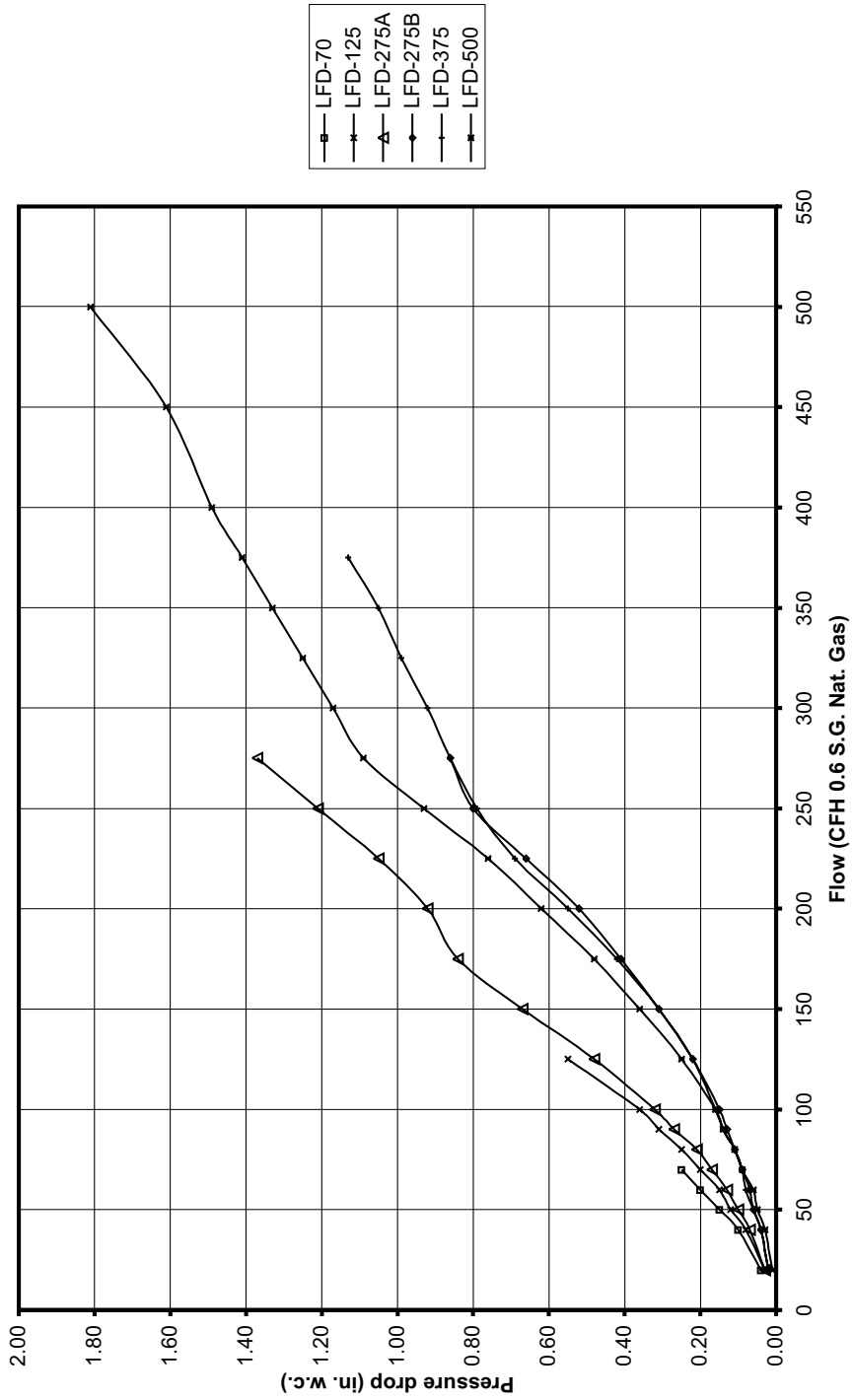





NOTES:

A series of horizontal lines for writing notes.

NOTES:

Lined area for taking notes, consisting of multiple horizontal lines.



*For more information about  
TracPipe® or CounterStrike® visit:  
**tracpipe.ca.**  
**omegaflex.com***  
*For safety issues concerning  
gas piping systems visit:  
**csstfacts.org***

---





**CounterStrike**<sup>®</sup>  
*For Enhanced Lightning Protection by TracPipe<sup>®</sup>*

**TracPipe**<sup>®</sup>  
*Flexible Gas Piping by OmegaFlex*

**OmegaFlex**<sup>®</sup>

451 Creamery Way  
Exton, PA 19341-2509  
1-800-671-8622 Fax: 610-524-7282  
[www.omegaflex.com](http://www.omegaflex.com)